

TUNING

FAI* RoHS Compliant

TUNING

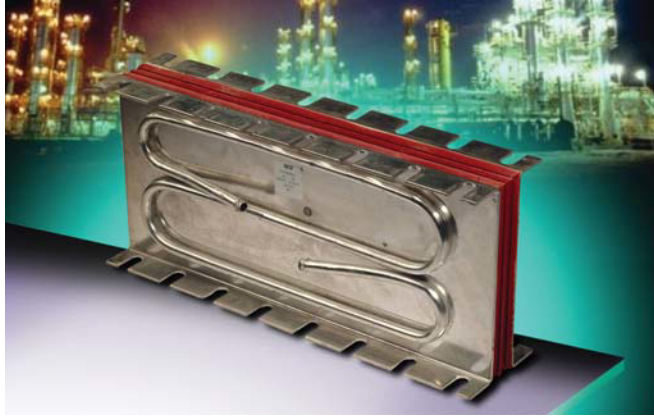

The FAI series uses metallized polypropylene dielectric specifically designed for very high reactive power.

The FAI's special design gives to this series a very low level of stray inductance.

APPLICATIONS

These capacitors have been designed principally for: low and medium frequency applications (10 kHz to 500 kHz).

MAXIMUM WORKING TEMPERATURE (HOT SPOT)

+85°C: Hot spot temperature must be calculated as function of power dissipation.

HOT SPOT (THERMAL) CALCULATION

See Hot Spot Temperature page 3.

You can calculate the maximum operating (hot spot) temperature of this capacitor in the following manner:

Polypropylene has a constant loss factor ($\text{tg}\delta_0$) of 2×10^{-4} irrespective of temperature and frequency (up to 1 MHz).

The loss factor of the capacitor is made up of the sum of two components. The first represents electrical losses ($\text{tg}\delta_0 = 2.10 \cdot 10^{-4}$) and the second represents Joule effect in the connection and foils: $R_s \cdot C \cdot 2\pi f$.

For all applications, the temperature in the hot spot capacitor must be lower than 85°C.

$$\theta \text{ hot spot} = \theta \text{ terminals} + (\text{tg}\delta_0 \cdot Q + R_s \cdot (I_{\text{rms}})^2) \cdot R_{\text{th}}$$

Heating calculation of hot spot capacitor: FAI6

$$\theta \text{ hot spot} = \theta \text{ water} + (\text{tg}\delta_0 Q + R_s \cdot (I_{\text{rms}})^2) \cdot R_{\text{th}}$$

With: $\text{tg}\delta_0 = 2.10 \cdot 10^{-4}$

Q in Var

R_s in Ohms

I_{rms} in Amperes

R_{th} in °C/W (water flow = 10 dm³/minute)

Note: The life time depends of hot spot temperature, see following curve.

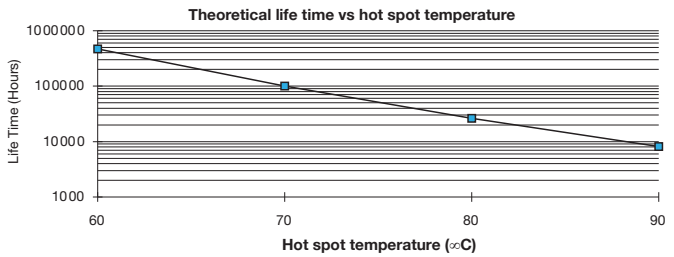

ELECTRICAL CHARACTERISTICS

Capacitance range C_n	110nF to 60µF
Tolerance	±10%
Rated AC voltage	200 to 650 Vrms
Series parasitic inductance	< 5 nH
Test voltage between terminals @ 25°C	1.2 Vrms 50/60 Hz 10s
Dielectric	Polypropylene

HOW TO ORDER

FAI
Series

1
Case Size

6
Dielectric

6 = Polypropylene

J
Voltage Code

H = 300 Vrms
I = 350 Vrms (Case size 3)
L = 400 Vrms (Case size 4)
J = 500 Vrms
K = 60 Vrms

0114
Capacitance Code

0 + pF code
0114 = 0.11µF (110nF)
0245 = 2.4µF (2400nF)
0405 = 4.0µF (4000nF)
etc.

K
Capacitance Tolerances

K = ±10%

--
Terminal Code

-- = Standard



Архангельск (8182)63-90-72
Астана (7172)727-132
Астрахань (8512)99-46-04
Барнаул (3852)73-04-60
Белгород (4722)40-23-64
Брянск (4832)59-03-52
Владивосток (423)249-28-31
Волгоград (844)278-03-48
Вологда (8172)26-41-59
Воронеж (473)204-51-73
Екатеринбург (343)384-55-89
Иваново (4932)77-34-06

Ижевск (3412)26-03-58
Иркутск (395)279-98-46
Казань (843)206-01-48
Калининград (4012)72-03-81
Калуга (4842)92-23-67
Кемерово (3842)65-04-62
Киров (8332)68-02-04
Краснодар (861)203-40-90
Красноярск (391)204-63-61
Курск (4712)77-13-04
Липецк (4742)52-20-81
Киргизия (996)312-96-26-47

Магнитогорск (3519)55-03-13
Москва (495)268-04-70
Мурманск (8152)59-64-93
Набережные Челны (8552)20-53-41
Нижний Новгород (831)429-08-12
Новокузнецк (3843)20-46-81
Новосибирск (383)227-86-73
Омск (3812)21-46-40
Орел (4862)44-53-42
Оренбург (3532)37-68-04
Пенза (8412)22-31-16
Россия (495)268-04-70

Пермь (342)205-81-47
Ростов-на-Дону (863)308-18-15
Рязань (4912)46-61-64
Самара (846)206-03-16
Саратов (845)249-38-78
Севастополь (8692)22-31-93
Симферополь (3652)67-13-56
Смоленск (4812)29-41-54
Сочи (862)225-72-31
Ставрополь (8652)20-65-13
Казахстан (772)734-952-31

Сургут (3462)77-98-35
Тверь (4822)63-31-35
Томск (3822)98-41-53
Тула (4872)74-02-29
Тюмень (3452)66-21-18
Ульяновск (8422)24-23-59
Уфа (347)229-48-12
Хабаровск (4212)92-98-04
Челябинск (351)202-03-61
Череповец (8202)49-02-64
Ярославль (4852)69-52-93

TUNING

FAI* RoHS Compliant

TUNING FAI1 STYLE CASE SIZE 1 DIMENSIONS

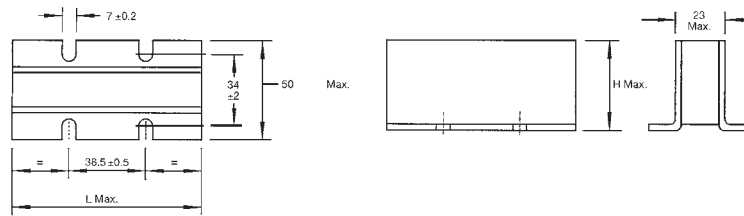

Part Number	C (nF)	Irms max (A)	Vrms max (V)	Q max kVARS	Rs (mΩ)	Rth (°C/W)	L max (mm)	H max (mm)	Typical Weight (g)
FAI16J0114K-	110	180	500	100	$8 \times 10^{-4} \times \sqrt{F} + 0.19$	0.86	55	35	125
FAI16J0214K-	210	300	500	150	$5 \times 10^{-4} \times \sqrt{F} + 0.12$	0.67	75	40	195
FAI16J0334K-	330	350	500	175	$5 \times 10^{-4} \times \sqrt{F} + 0.15$	0.54	75	40	195
FAI16J0514K-	510	500	500	250	$4 \times 10^{-4} \times \sqrt{F} + 0.08$	0.49	95	45	275
FAI16J0664K-	660	600	500	300	$3.5 \times 10^{-4} \times \sqrt{F} + 0.06$	0.38	95	45	275

With F in Hz

FAI2 STYLE CASE SIZE 2 DIMENSIONS

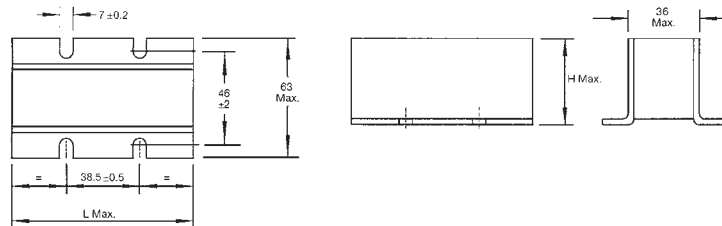

Part Number	C (nF)	Irms max (A)	Vrms max (V)	Q max kVARS	Rs (mΩ)	Rth (°C/W)	L max (mm)	H max (mm)	Typical Weight (g)
FAI26J0664K-	660	300	500	180	$5 \times 10^{-4} \times \sqrt{F} + 0.25$	0.6	75	40	300
FAI26J0125K-	1200	400	500	200	$5 \times 10^{-4} \times \sqrt{F} + 0.20$	0.56	75	40	300
FAI26I0245K-	2400	500	350	175	$5 \times 10^{-4} \times \sqrt{F} + 0.17$	0.55	75	40	300

With F in Hz

FAI3 STYLE CASE SIZE 3 DIMENSIONS

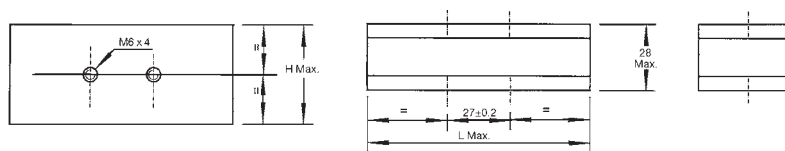

Part Number	C (nF)	Irms max (A)	Vrms max (V)	Q max kVARS	Rs (mΩ)	Rth (°C/W)	L max (mm)	H max (mm)	Typical Weight (g)
FAI36J0114K-	110	180	500	100	0.3	0.82	55	35	150
FAI36J0334K-	330	350	500	175	0.15	0.55	75	37	220
FAI36J0514K-	510	500	500	250	0.1	0.3	95	42	315
FAI36J0664K-	660	600	500	300	0.1	0.24	95	42	315

FAI4 STYLE CASE SIZE 4 DIMENSIONS

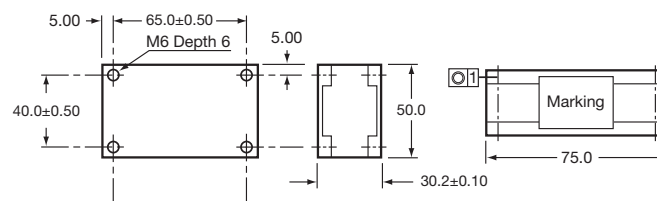

Part Number	C (nF)	Irms max (A)	Vrms max (V)	Q max kVARS	Rs (mΩ)	Rth (°C/W)	Typical Weight (g)
FAI46H0405K-	4000	600	300	180	0.13	0.15	315
FAI46I0245K-	2400	500	400	200	0.15	0.20	315
FAI46J0185K-	1800	550	450	230	0.35	0.38	315
FAI46J0125K-	1200	500	500	200	0.20	0.22	315
FAI46J0664K-	660	450	500	220	0.26	0.32	315
FAI46K0334K-	330	380	600	220	0.315	0.315	315
FAI46K0284K-	280	320	600	190	0.37	0.375	315

TUNING

FAI*RoHS Compliant

TUNING

110 nF 500 Vrms
FAI16J0114K--
FAI36J0114K--

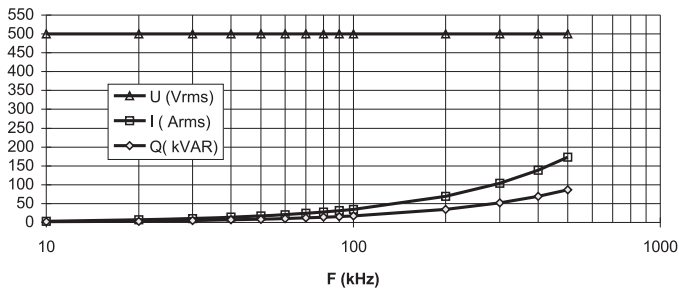

660 nF 500 Vrms
FAI16J0664K--
FAI36J0664K--

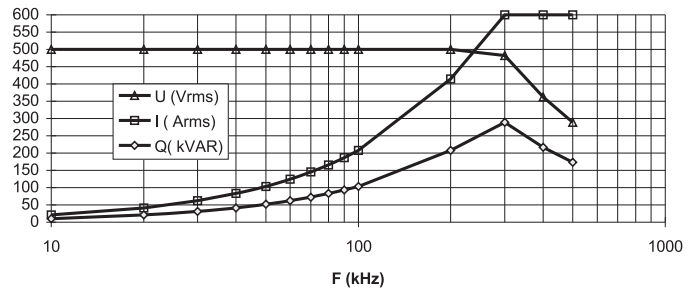

210 nF 500 Vrms
FAI16J0214K--

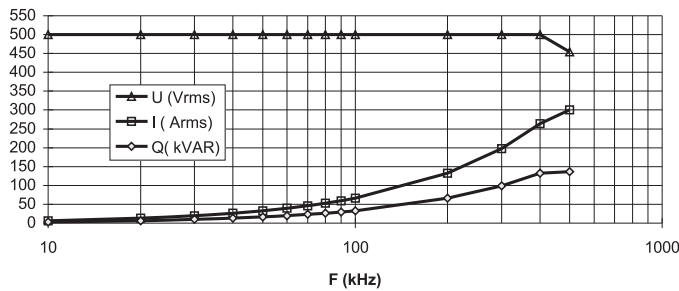

660 nF 500 Vrms
FAI26J0664K--

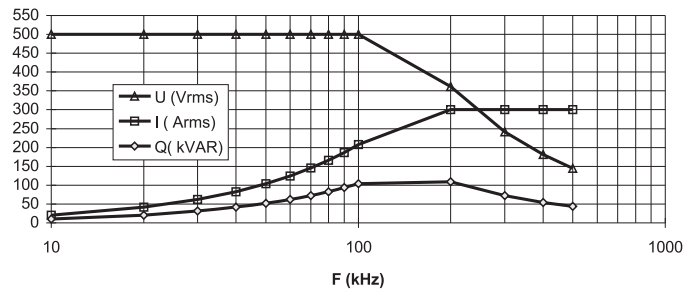

330 nF 500 Vrms
FAI16J0334K--
FAI36J0334K--

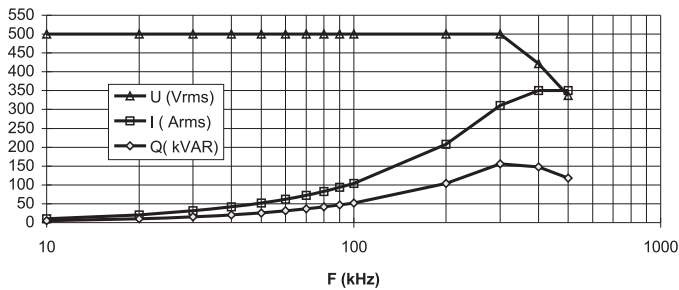

1200 nF 500 Vrms
FAI26J0125K--

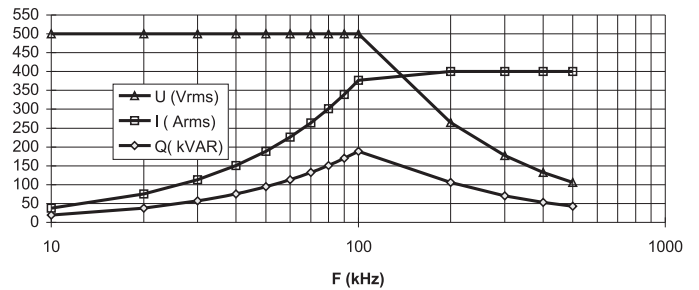

510 nF 500 Vrms
FAI16J0514K--
FAI36J0514K--

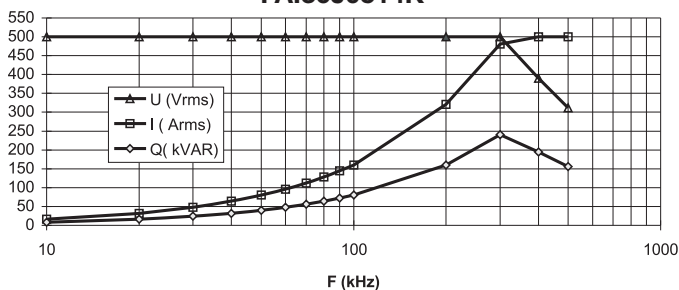

2400 nF 350 Vrms
FAI26J0245K--

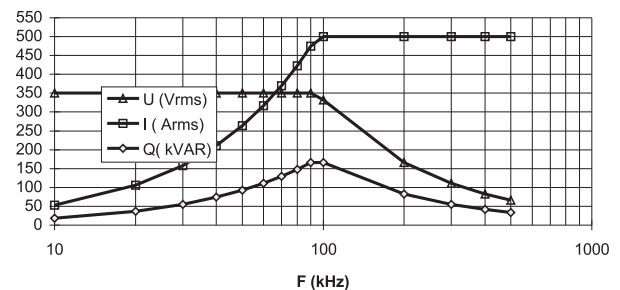

TUNING

FAI*RoHS Compliant

TUNING

FAI46H0405K--
4000nF±10% 300Vrms

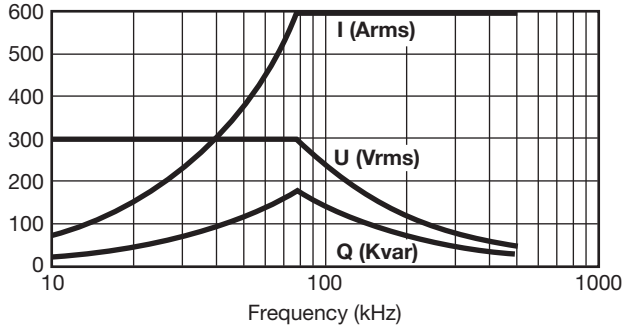

FAI46I0245K--
2400nF±10% 400Vrms

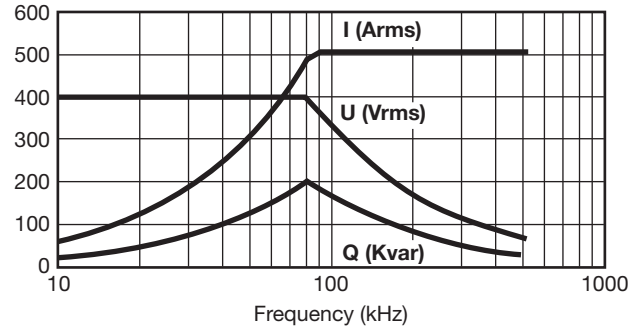

FAI46J0185K--
1800nF±10% 450Vrms

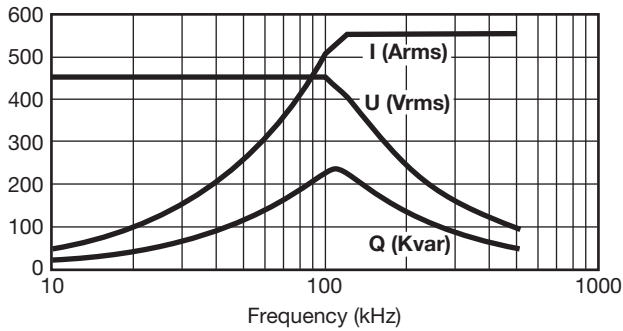

FAI46J0664K--
660nF±10% 500Vrms

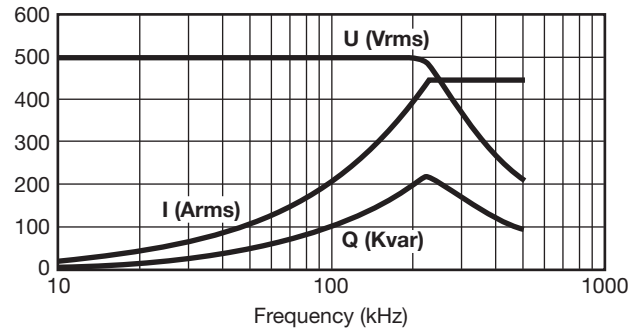

FAI46J0334K--
330nF±10% 600Vrms

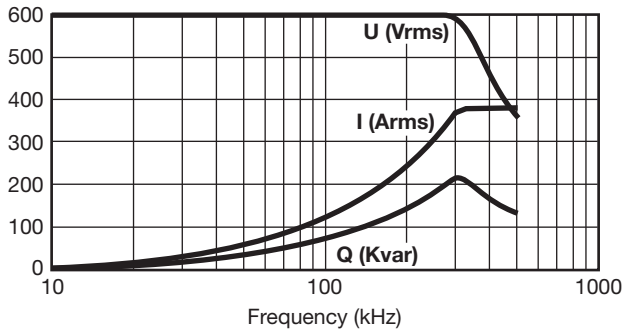

FAI46J0284K--
280nF±10% 600Vrms

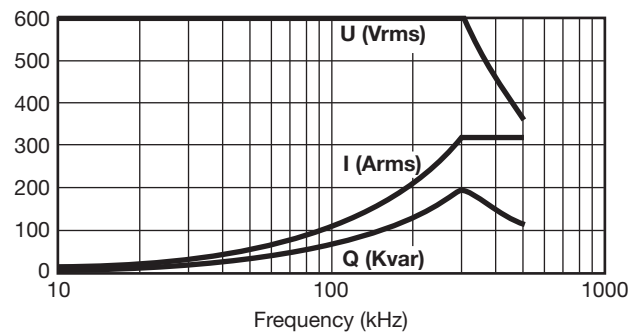

TUNING

FAI* RoHS Compliant

TUNING

FAI6

Part Number	Width (mm)	Vrms max (V)	C (μF)	Qmax (kVAR)	Irms max (A)	Rs (mΩ)	Rth (°C/W)	Typical Weight (g)
FAI66F0156K--	90	200	15	160	800	$5.10^{-4} \times \sqrt{f(\text{Hz})} + 0.025$	0.104	1900
FAI66H0126K--		300	12	240	800	$5.10^{-4} \times \sqrt{f(\text{Hz})} + 0.03$	0.104	1900
FAI66I0705K--		400	7	320	800	$5.10^{-4} \times \sqrt{f(\text{Hz})} + 0.035$	0.114	1900
FAI66J0505K--		500	5	320	640	$5.10^{-4} \times \sqrt{f(\text{Hz})} + 0.04$	0.114	1900
FAI66K0355K--		600	3.5	320	530	$5.10^{-4} \times \sqrt{f(\text{Hz})} + 0.05$	0.124	1900
FAI66A0155K--		650	1.5	320	490	$5.10^{-4} \times \sqrt{f(\text{Hz})} + 0.07$	0.134	1900
FAI66F0306K--	190	200	30	240	1200	$2.5.10^{-4} \times \sqrt{f(\text{Hz})} + 0.0125$	0.079	3950
FAI66H0246K--		300	24	360	1200	$2.5.10^{-4} \times \sqrt{f(\text{Hz})} + 0.015$	0.079	3950
FAI66I0146K--		400	14	480	1200	$2.5.10^{-4} \times \sqrt{f(\text{Hz})} + 0.0175$	0.084	3950
FAI66J0106K--		500	10	600	1200	$2.5.10^{-4} \times \sqrt{f(\text{Hz})} + 0.02$	0.084	3950
FAI66K0705K--		600	7	640	1070	$2.5.10^{-4} \times \sqrt{f(\text{Hz})} + 0.025$	0.089	3950
FAI66A0305K--		650	3	640	985	$2.5.10^{-4} \times \sqrt{f(\text{Hz})} + 0.035$	0.094	3950
FAI66F0456K--	290	200	45	320	1600	$2.10^{-4} \times \sqrt{f(\text{Hz})} + 0.0083$	0.072	6100
FAI66H0366K--		300	36	480	1600	$2.10^{-4} \times \sqrt{f(\text{Hz})} + 0.01$	0.072	6100
FAI66I0216K--		400	21	640	1600	$2.10^{-4} \times \sqrt{f(\text{Hz})} + 0.0117$	0.075	6100
FAI66J0156K--		500	15	800	1600	$2.10^{-4} \times \sqrt{f(\text{Hz})} + 0.0133$	0.075	6100
FAI66K1055K--		600	10.5	960	1600	$2.10^{-4} \times \sqrt{f(\text{Hz})} + 0.0167$	0.078	6100
FAI66A0455K--		650	4.5	960	1480	$2.10^{-4} \times \sqrt{f(\text{Hz})} + 0.0233$	0.082	6100
FAI66F0606K--	390	200	60	400	2000	$1.5.10^{-4} \times \sqrt{f(\text{Hz})} + 0.00625$	0.067	8200
FAI66H0486K--		300	48	600	2000	$1.5.10^{-4} \times \sqrt{f(\text{Hz})} + 0.0075$	0.067	8200
FAI66I0286K--		400	28	800	2000	$1.5.10^{-4} \times \sqrt{f(\text{Hz})} + 0.00875$	0.070	8200
FAI66J0206K--		500	20	1000	2000	$1.5.10^{-4} \times \sqrt{f(\text{Hz})} + 0.01$	0.070	8200
FAI66K0146K--		600	14	1200	2000	$1.5.10^{-4} \times \sqrt{f(\text{Hz})} + 0.0125$	0.072	8200
FAI66A0605K--		650	6	1280	1970	$1.5.10^{-4} \times \sqrt{f(\text{Hz})} + 0.0175$	0.075	8200

TUNING

FAI*RoHS Compliant

TUNING

CASE SIZE 6 DIMENSIONS

FAI6 WIDTH: 90 (3.543)

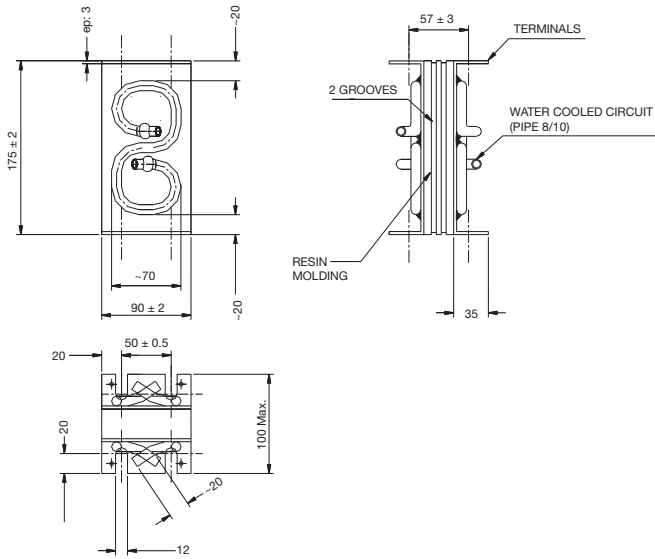

FAI6 WIDTH: 290 (11.417)

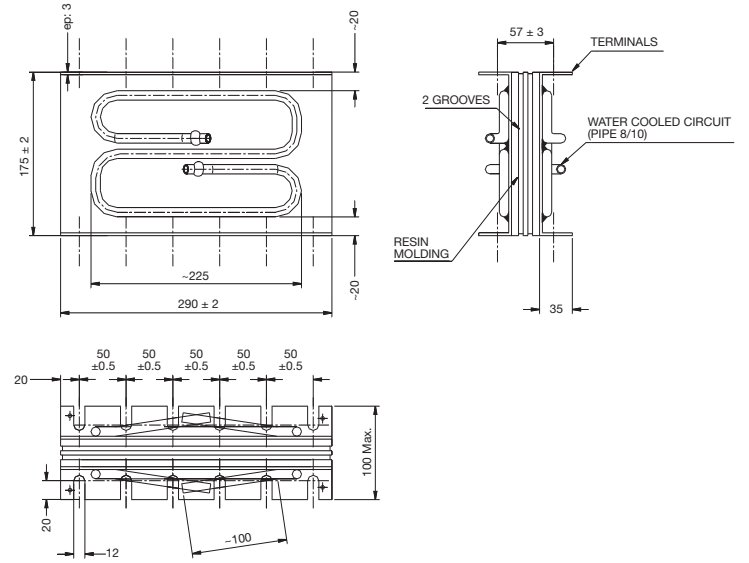

FAI6 WIDTH: 190 (7.480)

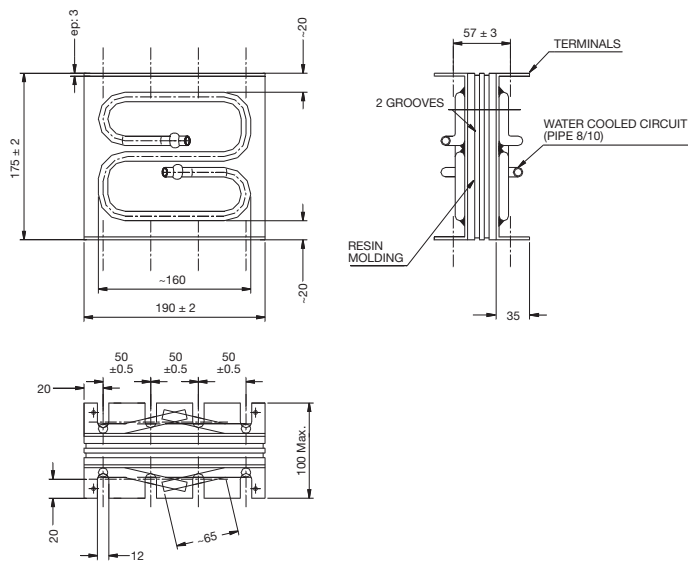

FAI6 WIDTH: 390 (15.354)

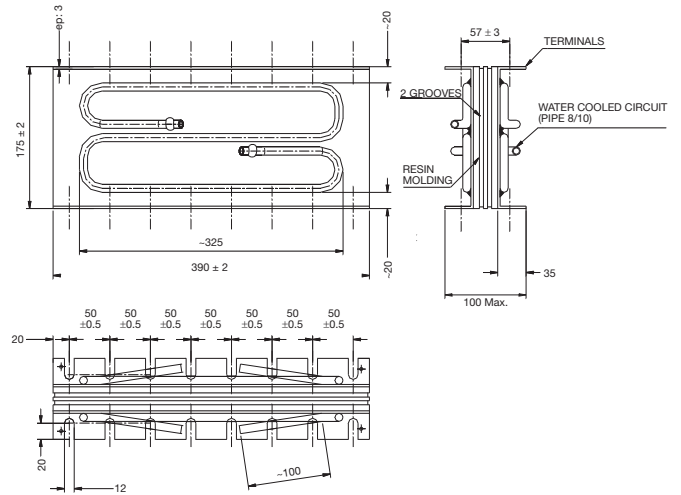

TUNING

FAI*RoHS Compliant

TUNING

15 μ F 200 Vrms Width 90 mm
FAI66F0156K--

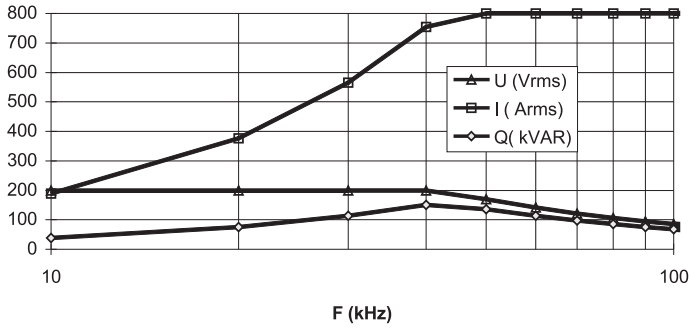

12 μ F 300 Vrms Width 90 mm
FAI66H0126K--

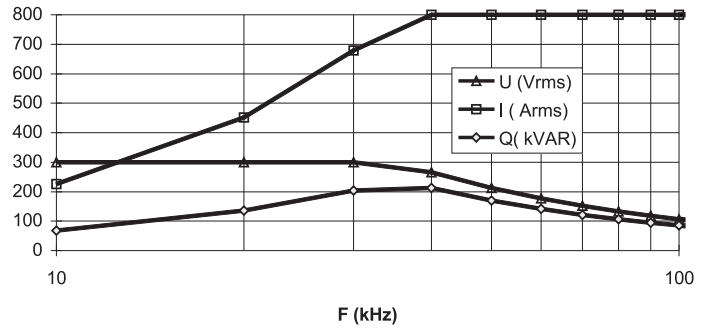

30 μ F 200 Vrms Width 190 mm
FAI66F0306K--

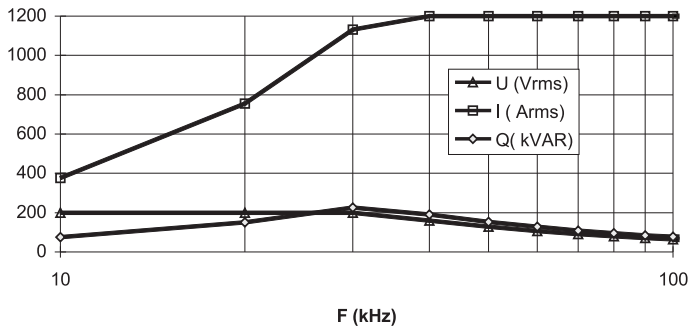

24 μ F 300 Vrms Width 190 mm
FAI66H0246K--

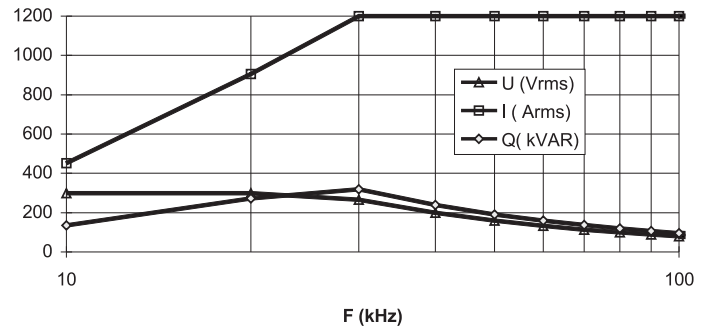

45 μ F 200 Vrms Width 290 mm
FAI66F0456K--

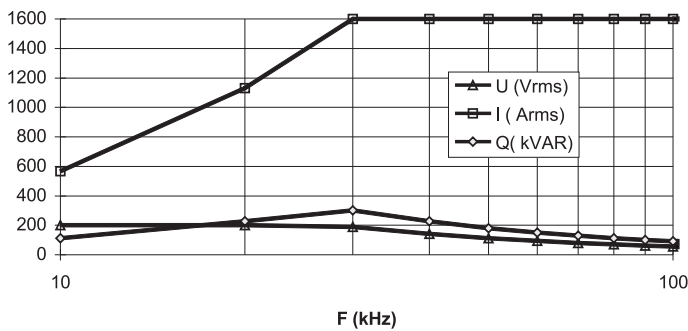

36 μ F 300 Vrms Width 290 mm
FAI66H0366K--

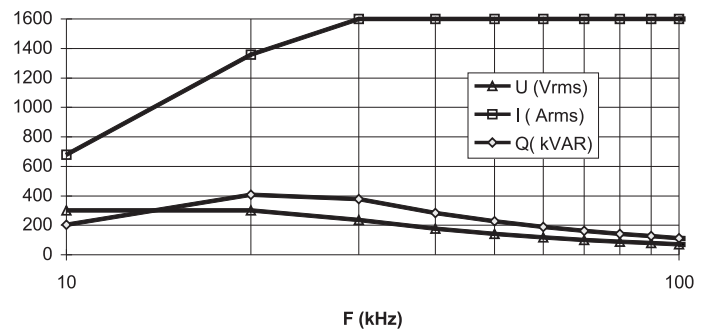

60 μ F 200 Vrms Width 390 mm
FAI66F0606K--

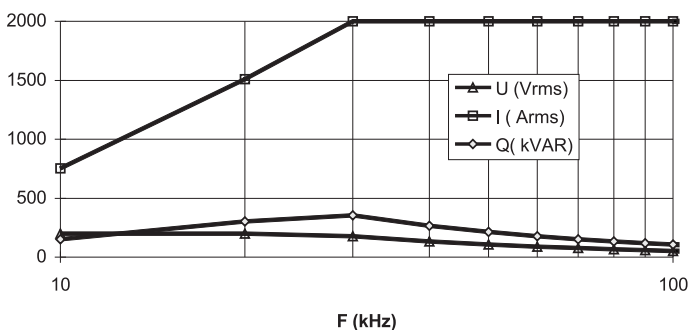

48 μ F 300 Vrms Width 390 mm
FAI66H0486K--

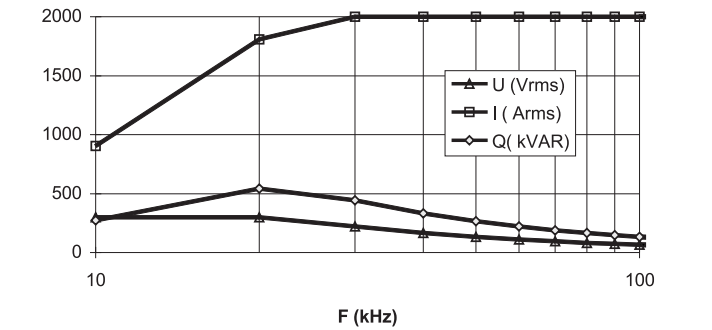

TUNING

FAI* RoHS Compliant

TUNING

7 μ F 400 Vrms Width 90 mm
FAI66I0705K--

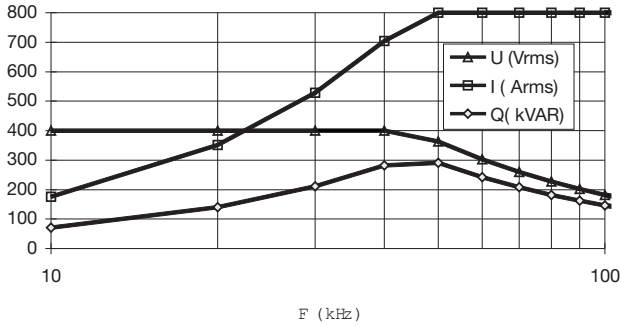

5 μ F 500 Vrms Width 90 mm
FAI66J0505K--

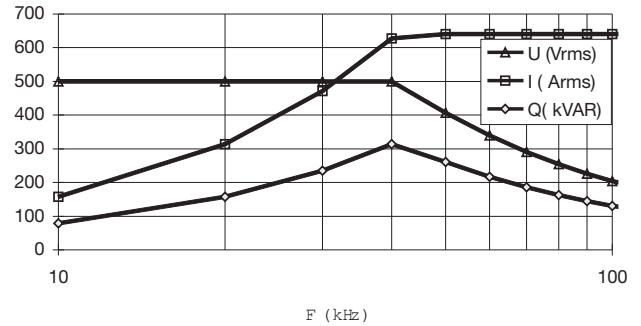

14 μ F 400 Vrms Width 190 mm
FAI66I0146K--

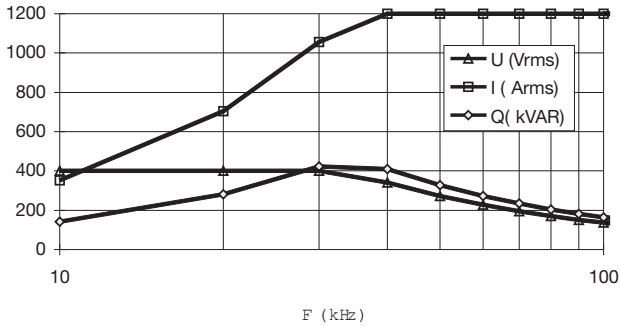

10 μ F 500 Vrms Width 190 mm
FAI66J0106K--

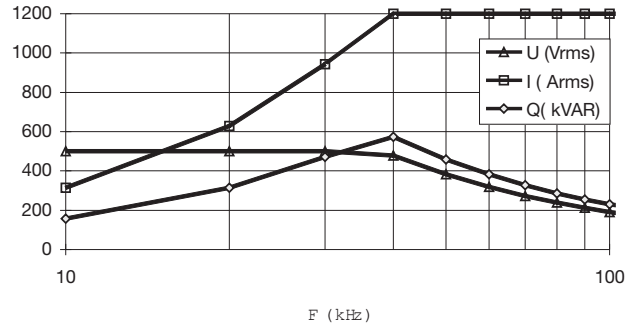

21 μ F 400 Vrms Width 290 mm
FAI66I0216K--

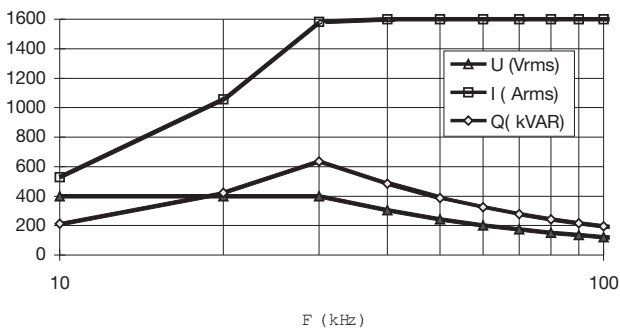

15 μ F 500 Vrms Width 290 mm
FAI66J0156K--

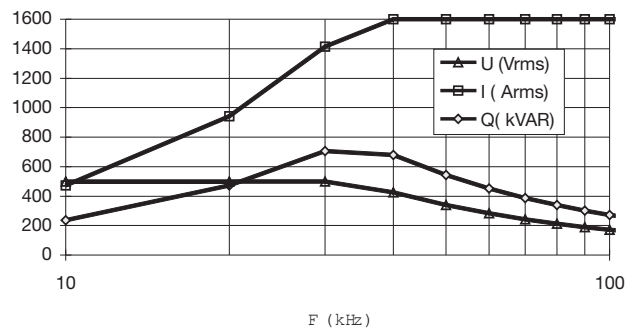

28 μ F 400 Vrms Width 390 mm
FAI66I0286K--

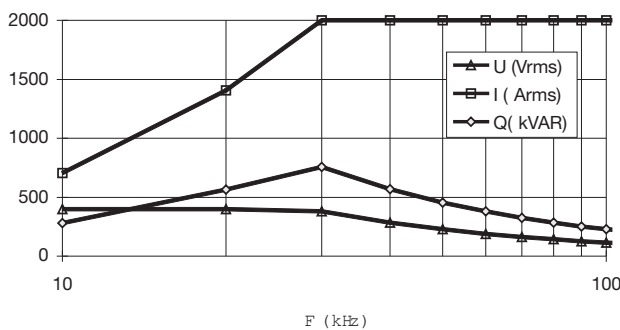

20 μ F 500 Vrms Width 390 mm
FAI66J0206K--

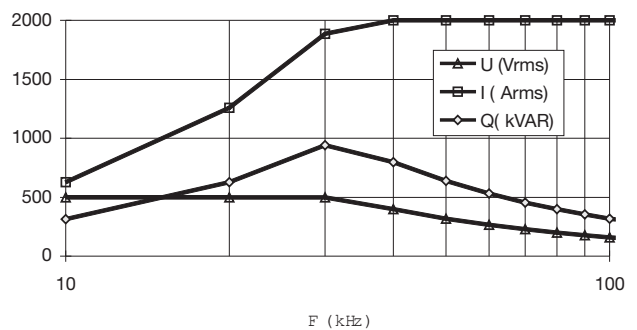

TUNING

**3.5 μ F 600 Vrms Width 90 mm
FAI66K0355K--**

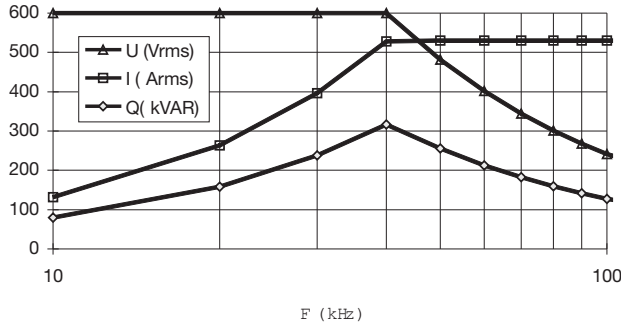

**1.5 μ F 650 Vrms Width 90 mm
FAI66A0155K--**

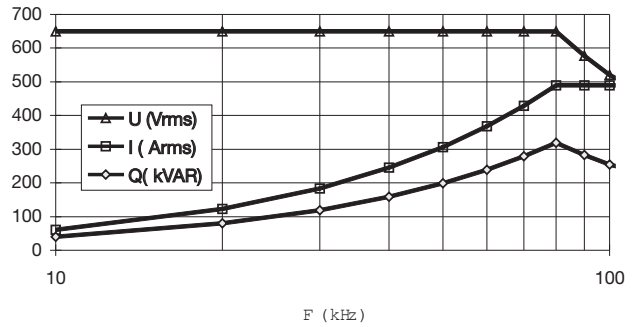

**7 μ F 600 Vrms Width 190 mm
FAI66K0705K--**

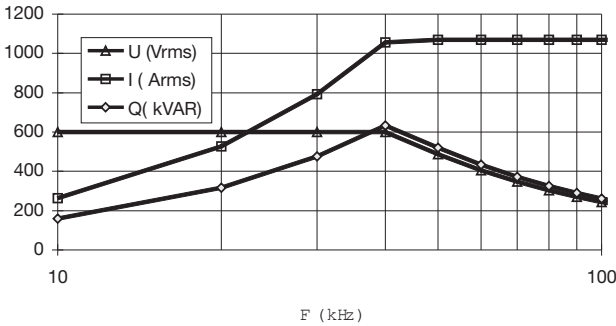

**3 μ F 650 Vrms Width 190 mm
FAI66A0305K--**

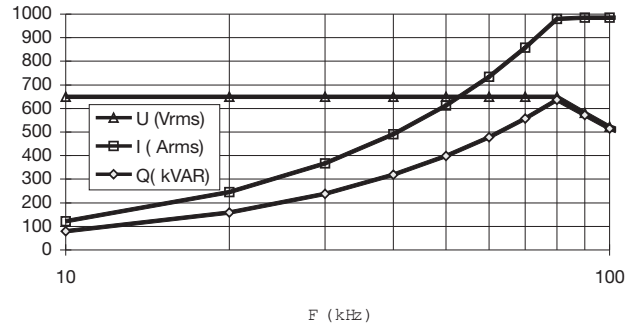

**10.5 μ F 600 Vrms Width 290 mm
FAI66K1055K--**

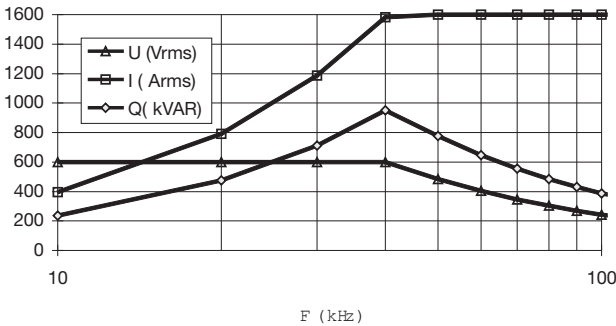

**4.5 μ F 650 Vrms Width 290 mm
FAI66A0455K--**

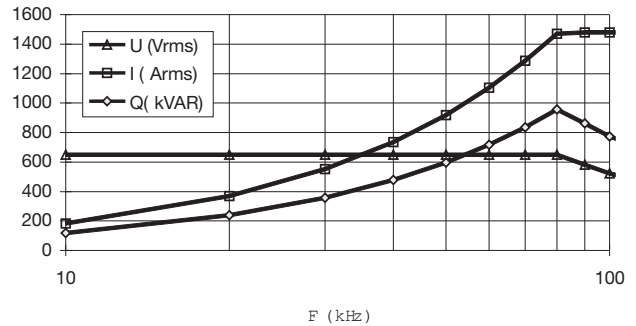

**14 μ F 600 Vrms Width 390 mm
FAI66K0146K--**

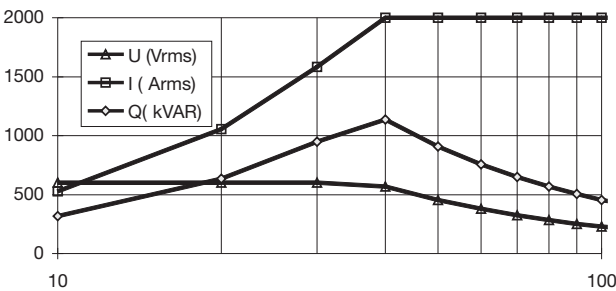

**6 μ F 650 Vrms Width 390 mm
FAI66A0605K--**

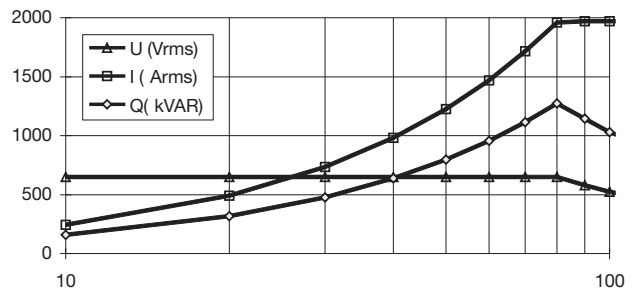

Архангельск (8182)63-90-72
Астана (7172)727-132
Астрахань (8512)99-46-04
Барнаул (3852)73-04-60
Белгород (4722)40-23-64
Брянск (4832)59-03-52
Владивосток (423)249-28-31
Волгоград (844)278-03-48
Вологда (8172)26-41-59
Воронеж (473)204-51-73
Екатеринбург (343)384-55-89
Иваново (4932)77-34-06

Ижевск (3412)26-03-58
Иркутск (395)279-98-46
Казань (843)206-01-48
Калининград (4012)72-03-81
Калуга (4842)92-23-67
Кемерово (3842)65-04-62
Киров (8332)68-02-04
Краснодар (861)203-40-90
Красноярск (391)204-63-61
Курск (4712)77-13-04
Липецк (4742)52-20-81
Киргизия (996)312-96-26-47

Магнитогорск (3519)55-03-13
Москва (495)268-04-70
Мурманск (8152)59-64-93
Набережные Челны (8552)20-53-41
Нижний Новгород (831)429-08-12
Новокузнецк (3843)20-46-81
Новосибирск (383)227-86-73
Омск (3812)21-46-40
Орел (4862)44-53-42
Оренбург (3532)37-68-04
Пенза (8412)22-31-16
Россия (495)268-04-70

Пермь (342)205-81-47
Ростов-на-Дону (863)308-18-15
Рязань (4912)46-61-64
Самара (846)206-03-16
Санкт-Петербург (812)309-46-40
Саратов (845)249-38-78
Севастополь (8692)22-31-93
Симферополь (3652)67-13-56
Соленск (4812)29-41-54
Сочи (862)225-72-31
Ставрополь (8652)20-65-13
Казахстан (772)734-952-31

Сургут (3462)77-98-35
Тверь (4822)63-31-35
Томск (3822)98-41-53
Тула (4872)74-02-29
Тюмень (3452)66-21-18
Ульяновск (8422)24-23-59
Уфа (347)229-48-12
Хабаровск (4212)92-98-04
Челябинск (351)202-03-61
Черовец (8202)49-02-64
Ярославль (4852)69-52-93