

Архангельск (8182)63-90-72
Астана (7172)727-132
Астрахань (8512)99-46-04
Барнаул (3852)73-04-60
Белгород (4722)40-23-64
Брянск (4832)59-03-52
Благовосток (423)249-28-31
Волгоград (844)278-03-48
Вологда (8172)26-41-59
Воронеж (473)204-51-73
Екатеринбург (343)384-55-89
Иваново (4932)77-34-06

Ижевск (3412)26-03-58
Иркутск (395)279-98-46
Казань (843)206-01-48
Калининград (4012)72-03-81
Калуга (4842)92-23-67
Кемерово (3842)65-04-62
Киров (8332)68-02-04
Краснодар (861)203-40-90
Красноярск (391)204-63-61
Курск (4712)77-13-04
Липецк (4742)52-20-81
Киргизия (996)312-96-26-47

Магнитогорск (3519)55-03-13
Москва (495)268-04-70
Мурманск (8152)59-64-93
Набережные Челны (8552)20-53-41
Нижний Новгород (831)429-08-12
Новокузнецк (3843)20-46-81
Новосибирск (383)227-86-73
Омск (3812)21-46-40
Орел (4862)44-53-42
Оренбург (3532)37-68-04
Пенза (8412)22-31-16
Россия (495)268-04-70

Пермь (342)205-81-47
Ростов-на-Дону (863)308-18-15
Рязань (4912)46-61-64
Самара (846)206-03-16
Санкт-Петербург (812)309-46-40
Саратов (845)249-38-78
Севастополь (8692)22-31-93
Симферополь (3652)67-13-56
Смоленск (4812)29-41-54
Сочи (862)225-72-31
Ставрополь (8652)20-65-13
Казахстан (772)734-952-31

Сургут (3462)77-98-35
Тверь (4822)63-31-35
Томск (3822)98-41-53
Тула (4872)74-02-29
Тюмень (3452)66-21-18
Ульяновск (8422)24-23-59
Уфа (347)229-48-12
Хабаровск (4212)92-98-04
Челябинск (351)202-03-61
Череповец (8202)49-02-64
Ярославль (4852)69-52-93

<https://avx.nt-rt.ru/> || avx@nt-rt.ru



Wire-to-Board Connectors

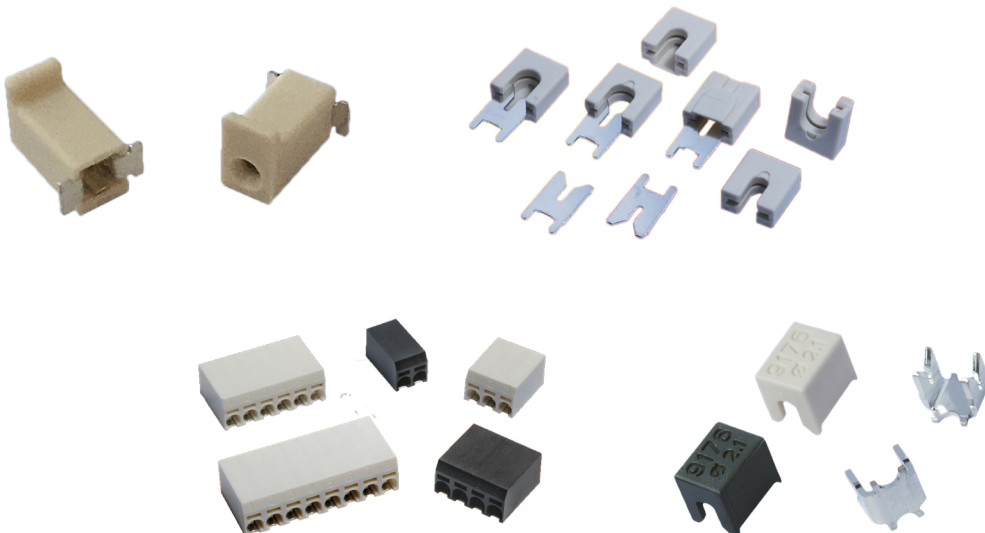

IMPORTANT INFORMATION/DISCLAIMER

All product specifications, statements, information and data (collectively, the “Information”) in this datasheet or made available on the website are subject to change. The customer is responsible for checking and verifying the extent to which the Information contained in this publication is applicable to an order at the time the order is placed. All Information given herein is believed to be accurate and reliable, but it is presented without guarantee, warranty, or responsibility of any kind, expressed or implied.

Statements of suitability for certain applications are based on KYOCERA AVX knowledge of typical operating conditions for such applications, but are not intended to constitute and KYOCERA AVX specifically disclaims any warranty concerning suitability for a specific customer application or use.

ANY USE OF PRODUCT OUTSIDE OF SPECIFICATIONS OR ANY STORAGE OR INSTALLATION INCONSISTENT WITH PRODUCT GUIDANCE VOIDS ANY WARRANTY.

The Information is intended for use only by customers who have the requisite experience and capability to determine the correct products for their application. Any technical advice inferred from this Information or otherwise provided by KYOCERA AVX with reference to the use of KYOCERA AVX products is given without regard, and KYOCERA AVX assumes no obligation or liability for the advice given or results obtained.

Although KYOCERA AVX designs and manufactures its products to the most stringent quality and safety standards, given the current state of the art, isolated component failures may still occur. Accordingly, customer applications which require a high degree of reliability or safety should employ suitable designs or other safeguards (such as installation of protective circuitry or redundancies) in order to ensure that the failure of an electrical component does not result in a risk of personal injury or property damage.

Unless specifically agreed to in writing, KYOCERA AVX has not tested or certified its products, services or deliverables for use in high risk applications including medical life support, medical device, direct physical patient contact, water treatment, nuclear facilities, weapon systems, mass and air transportation control, flammable environments, or any other potentially life critical uses. Customer understands and agrees that KYOCERA AVX makes no assurances that the products, services or deliverables are suitable for any high-risk uses. Under no circumstances does KYOCERA AVX warrant or guarantee suitability for any customer design or manufacturing process.

Although all product-related warnings, cautions and notes must be observed, the customer should not assume that all safety measures are indicated or that other measures may not be required.

WIRE-TO-BOARD CONNECTORS

Table of Contents

STANDARD 26-28 AWG: 00-9175

General Information	1
2 Position.....	2
3 Position.....	3
Accessory Cap - Through Wire	4
Accessory Cap - Wire Stop	5
Hand Insertion Tooling / Clearance Area on PCB for Hand Tooling	6
Insertion Tooling Requires Hand Press with Flat Rock Plates	7

CAPPED IDC 26-28 AWG: 9175-700

General Information	8
2 Position - Through Wire.....	9
3 Position - Through Wire.....	10
2 Position - Wire Stop.....	11
3 Position - Wire Stop.....	12
Assembly - Through Wire and Wire Stop	13

STANDARD IDC 18-24 AWG: 00-9176

General Information	14
1 Position.....	16
2 Position.....	17
3 Position.....	18
Accessory Cap - Through Wire	19
Accessory Cap - Wire Stop	20
Hand Insertion Tooling for Single 18/24 Gauge Wire	21
Insertion Tooling Requires Hand Press with Flat Rock Plates	22
Hand Insertion Tooling for One Way Cap Insertion / Clearance Area on PCB for Hand Tooling	23
Assembled Connector	24

CAPPED 18-24 AWG: 9176-700

General Information	25
1 Position - Through Wire.....	26
2 Position - Through Wire.....	27
3 Position - Through Wire.....	28
1 Position - Wire Stop.....	29
2 Position - Wire Stop.....	30
3 Position - Wire Stop.....	31
Assembly - Through Wire and Wire Stop	32

SINGLE IDC CONTACT 22-28 AWG: 9176-400

General Information	33
Contact Details.....	34
PCB Layout	35
Assembly Tooling	36
Cap Details.....	38

SINGLE IDC CONTACT 18-24 AWG: 9176-500

General Information	39
Contact Details.....	40
PBC Layout	41
Assembly Tooling	42
Cap Details.....	44

SINGLE IDC CONTACT 12-18 AWG: 9177-500

General Information	45
Contact Detail	46

IDC Wire to Board Connector Single Contact	47
Assembly Tooling	48

SINGLE TINE PTH 18-24 AWG: 9176-600

General Information	49
1 Position - Through Wire.....	50
1 Position - Wire Stop.....	51
Assembly - Through Wire and Wire Stop	52

SINGLE TINE SMT 18-24 AWG: 9176-650

General Information	53
1 Position - Through Wire.....	54
1 Position - Wire Stop.....	55
Assembly - Through Wire and Wire Stop	56

LOW PROFILE IDC 22-30 AWG: 9176-800

General Information	57
1 Position.....	58
2 Position.....	59
3 Position.....	60
4 Position.....	61
Conector Details.....	62

STANDARD 14-20 AWG: 00-9177

General Information	63
1 Position.....	65
2 Position.....	66
3 Position.....	67
Assesory Cap - Through Wire	68
Assesory Cap - Wire Stop	69
Insertion Tooling.....	70
Assembled Connector	71

CAPPED THRU HOLE 12-18 AWG: 00-9177

General Information	72
1 Position - Through Wire.....	73
1 Position - Wire Stop.....	74

SINGLE THRU HOLE IDC CONTACT 12-18 AWG: 9177-600

General Information	75
Contact Details.....	76
Assembly Tooling	77
Accessory Cap - Through Wire	78
Accessory Cap - Wire Stop	79

POKE-HOME: HORIZONTAL

18-26 AWG: 00-9276

General Information	80
Wire Assembly/Wire Extraction	81
1 Position.....	82
2 Position.....	83
3 Position.....	84
4 Position.....	85
6 Position.....	86
8 Position.....	87

WIRE-TO-BOARD CONNECTORS

Table of Contents

POKE-HOME: SINGLE HORIZONTAL CONTACT

12-28 AWG: 70-9296

General Information	88
1.7mm	89
2mm	90
2.5mm	91
2.5mm – No Stop	92
3mm	93
4mm	94
Connector Assembly / Contact Opening Tool	95

POKE-HOME: VERTICAL TOP ENTRY

18-26 AWG: 00-9296

General Information	96
1 Position.....	97
2 Position.....	98
3 Position.....	99
4 Position.....	100
5 Position.....	101
6 Position.....	102
Connector Assembly / Contact Opening Tool	103

POKE-HOME: INVERTED THRU BOARD

18-26 AWG: 00-9296

General Information	104
1 Position.....	105
2 Position.....	106
3 Position.....	107
4 Position.....	108
5 Position.....	109
6 Position.....	110
Wire Strip Length	111

SINGLE VERTICAL TOP ENTRY

18 AWG: 58-9296

General Information	112
Single Vertical Top Entry	113

STANDARD VERTICAL TOP ENTRY 18-22AWG

00-9296	114
00-9296	115

POKE-HOME: SINGLE VERTICAL CONTACT

18-24 AWG: 70-9296

General Information	116
Top Side Contact - Bottom Entry Wire (FR4 Board)	117
Through Board Contact - Top Entry Wire (FR4 Board)	118
Top Side Contact - Bottom Entry Wire (Metal Board)	119
Through Board Contact - Top Entry Wire (Metal Board)	120
Wire Trim Details.....	121

POKE-HOME: MICRO SINGLE VERTICAL CONTACT

22-26 AWG: 70-9296

General Information	122
Top Side Contact - Bottom Entry Wire (FR4 Board)	123
Through Board Contact - Top Entry Wire (FR4 Board)	124
Top Side Contact - Bottom Entry Wire (Metal Board)	125
Through Board Contact - Top Entry Wire (Metal Board)	126
Wire Trim Details.....	127

POKE-HOME: LOW PROFILE HORIZONTAL

20-26 AWG: 9296-200

General Information	128
1 Position.....	129
2 Position.....	130
3 Position.....	131
4 Position.....	132
5 Position.....	133
6 Position.....	134
Assembly.....	135

RF COAXIAL IDC..... 136

STANDARD 26-28 AWG: 00-9175

General Information

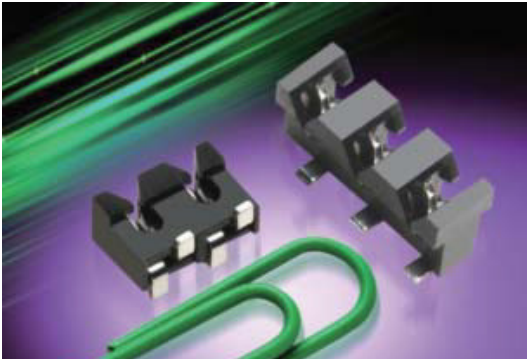

The 917X series of surface mount Insulation Displacement Connectors (IDC) were developed to meet the harsh automotive and industrial market applications for connecting individual wires directly to a PCB ranging from 14 AWG to 28 AWG. This industry proven contact system has been tested to automotive levels of shock, vibration, and temperature cycling to prove their reliability and robustness. The simplicity of inserting a wire into the connector with a small tool allows a wide range of devices to be connected to the PCB without soldering. In SSL applications specifically, these connectors are used to bring power and signal onto the PCB or are used to daisy chain multiple boards together in a long string. While the IDC contact provides a gas-tight connection to conductor of the wire, the housing has been designed to grab the insulation of the wire to provide a positive strain relief even in the harshest conditions. In case of repair, the wires can be removed and replaced up to three times.

The 9175 series accepts 26 AWG to 28 AWG wires with an insulation diameter ranging from 0.7mm to 1.0mm. These single contact connectors support a 1 amp current rating and have a split SMT tail design to provide maximum stability on the PCB. Available in a 2p and 3p configuration, these connectors can be end stackable for higher pin counts.

APPLICATIONS

- Connecting discrete wire components directly to the PCB
- Bringing power and signals onto a PCB
- Daisy chaining PCB's together to create a continuous string of boards
- Application Notes: refer to 201-01-124

FEATURES AND BENEFITS

- IDC contact provides a gas-tight connection to the PCB for long term reliability
- Connector housing captures the wire insulation for positive strain relief
- Tested to automotive levels on shock, vibration and temperature cycling for reliability
- Low and high volume assembly tools to match production volumes
- Reduced total applied cost versus solder or crimp processes
- High temperature insulator capable to 260 degrees C reflow soldering processes

ELECTRICAL

- Current Rating: 1 Amp / Contact
- Voltage Rating: 150 VAC

ENVIRONMENTAL

- Operating Temperature: -40°C to +125°C

MECHANICAL

- Insulator Material: Nylon 46: UL94V0
- Contact Material: Phosphor Bronze
- Plating: Tin over Nickel
- Durability: 3 Cycles

HOW TO ORDER

00 Prefix
9159 Series

00X Number of Ways

00X Wire Gauge Size

X Insulator Color
9 = UL White
8 = UL Black
Special Order

06 Plating Option
06 = Pure Tin all over



Code	No of Ways	Details
002	2	Page 4
003	3	Page 5

Code	Accepted Wire Gauge	Wire Insulation
001	28 Gauge Solid or Stranded	Ø 0.70 to Ø 1.00
002	26 Gauge Solid or Stranded	Ø 0.70 to Ø 1.00

CONNECTOR/TOOLING PART NUMBER MATRIX

SERIES 9175 IDC					HAND INSERTION TOOLING*			ACCESSORY CAPS	
AWG	Wire Insulation	Positions	Color	Part Number	Plastic (medium volume)	Metal (high volume)	Mass Termination	Though Wire	Wire Stop
26	Ø 0.7 - 1.0	2p	White	009175002002906	069175701601000	069175701701000	069175701701002	609175002010100	609175002010199
26	Ø 0.7 - 1.0	2p	Black	009175002002806	069175701601000	069175701701000	069175701701002	609175002010000	609175002010099
26	Ø 0.7 - 1.0	3p	White	009175003002906	069175701601000	069175701701000	069175701701003	609175003010100	609175003010199
26	Ø 0.7 - 1.0	3p	Black	009175003002806	069175701601000	069175701701000	069175701701003	609175003010000	609175003010099
28	Ø 0.7 - 1.0	2p	White	009175002001906	069175701601000	069175701701000	069175701701002	609175002010100	609175002010199
28	Ø 0.7 - 1.0	2p	Black	009175002001806	069175701601000	069175701701000	069175701701002	609175002010000	609175002010099
28	Ø 0.7 - 1.0	3p	White	009175003001906	069175701601000	069175701701000	069175701701003	609175003010100	609175003010199
28	Ø 0.7 - 1.0	3p	Black	009175003001806	069175701601000	069175701701000	069175701701003	609175003010000	609175003010099

* Hand Insertion Tooling - Universal Hand Tool 067000773001000; Consult Application Notes 201-01-124

Certification: UL File #E90723

STANDARD 26-28 AWG: 00-9175

2 Position

26-28 AWG 2 WAY IDC CONNECTOR

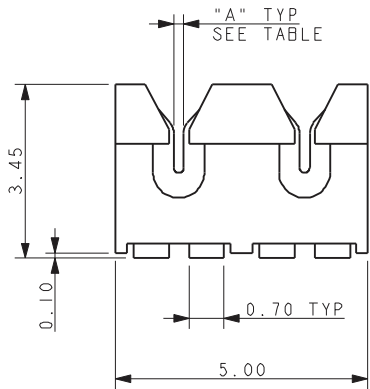
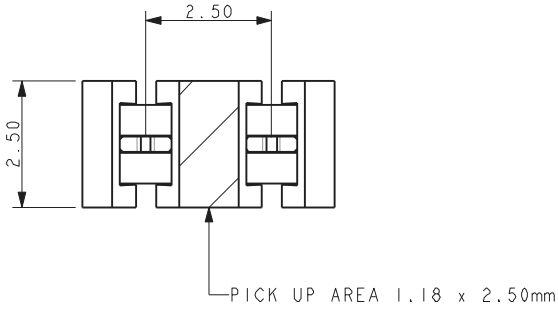

Code	Wire Gauge	A
001	28AWG	0.20
002	26AWG	0.28

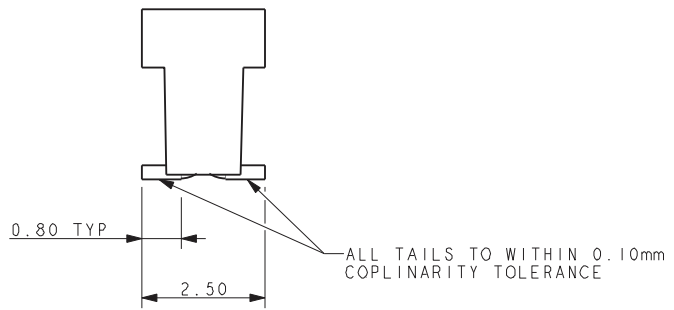

SMT PCB LAYOUT PURE TIN PADS

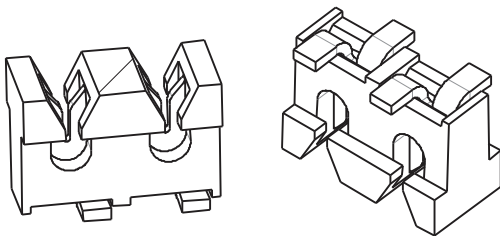
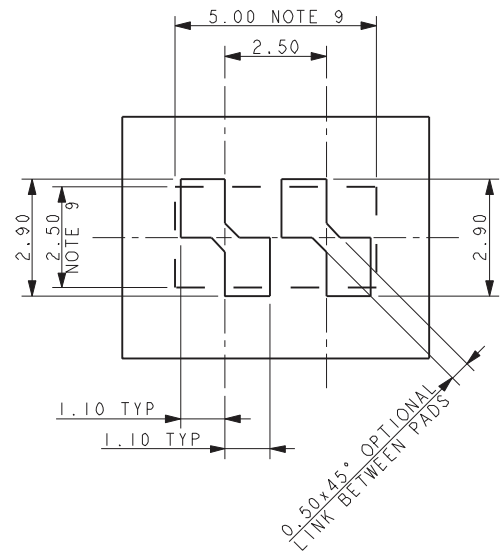

PACKING DETAILS

REEL QTY	2000
LEADER	500MM
TRAILER	500MM

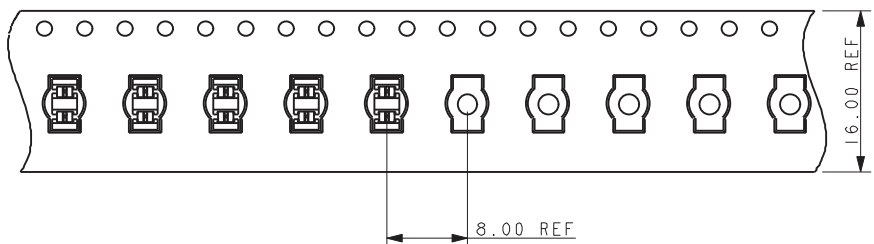
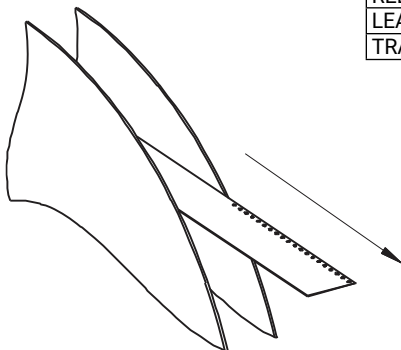

NOTES:

- CONNECTOR FOR IDC WIRE TO BOARD CONNECTION.
- CONTACT MATERIAL: PHOSPHOR BRONZE.
INSULATION MATERIAL: HIGH TEMPERATURE NYLON 46.
COLOR REFER TO PAGE 3.
- CONNECTOR DESIGNED TO ACCEPT 26 AND 28 GAUGE SOLID OR STRANDED WIRE.
- ALL DIMENSIONS FOR REFERENCE UNLESS OTHERWISE STATED.
- FOR FULL PRODUCT SPECIFICATION ON STANDARD CONNECTORS REFER TO ELCO SPEC 201-01-100, UL COMPONENTS REFER TO ELCO SPEC 201-01-100UL.
- APPLICATION NOTES 201-01-124.
- FOR UL PRODUCT CODES UL REFERENCE 390723 (US AND CANADA).
- CONNECTOR OUTLINE.
- ALL DIMENSIONS ± 0.20 UNLESS TOLERANCE SPECIFIED.

STANDARD 26-28 AWG: 00-9175

3 Position

26-28 AWG 3 WAY IDC CONNECTOR

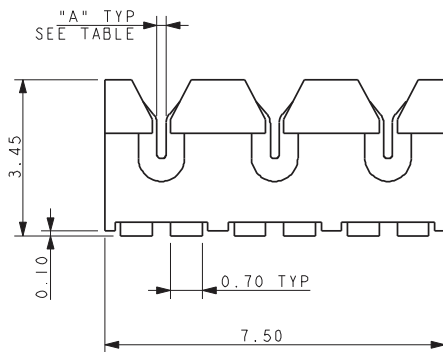
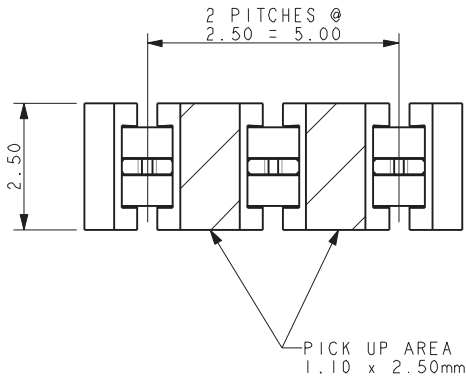

Code	Wire Gauge	A
001	28AWG	0.20
002	26AWG	0.28

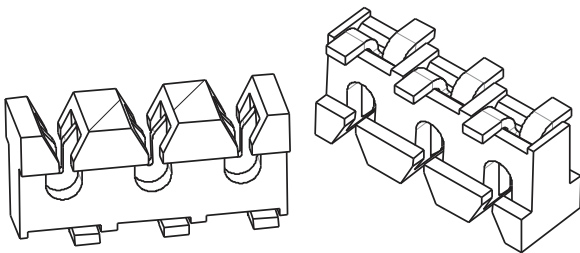

PACKING DETAILS

REEL QTY	2000
LEADER	500MM
TRAILER	500MM

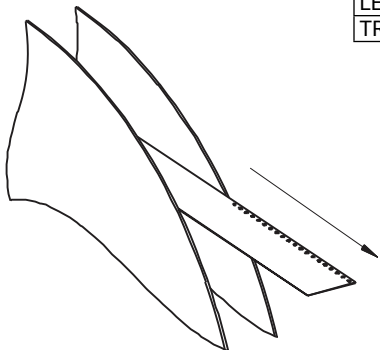

NOTES:

- CONNECTOR FOR IDC WIRE TO BOARD CONNECTION.
- CONTACT MATERIAL: PHOSPHOR BRONZE.
INSULATION MATERIAL: HIGH TEMPERATURE NYLON 46.
COLOR REFER TO PAGE 3.
- CONNECTOR DESIGNED TO ACCEPT 26 AND 28 GAUGE SOLID OR STRANDED WIRE.
- ALL DIMENSIONS FOR REFERENCE UNLESS OTHERWISE STATED.
- FOR FULL PRODUCT SPECIFICATION ON STANDARD CONNECTORS REFER TO ELCO SPEC 201-01-100, UL COMPONENTS REFER TO ELCO SPEC 201-01-100UL.
- APPLICATION NOTES 201-01-124.
- FOR UL PRODUCT CODES UL REFERENCE 390723 (US AND CANADA).
- CONNECTOR OUTLINE.
- ALL DIMENSIONS ± 0.20 UNLESS TOLERANCE SPECIFIED.

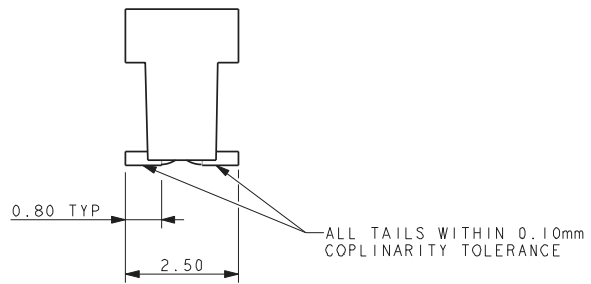

SMT PCB LAYOUT PURE TIN PADS

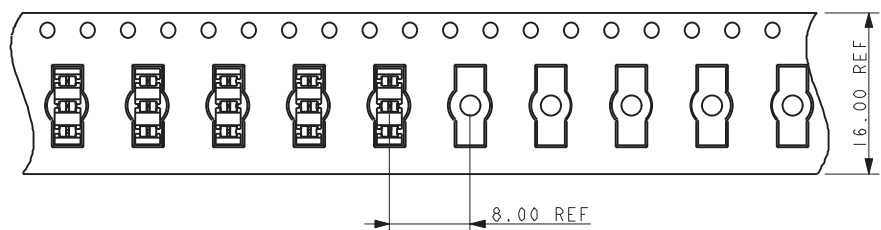
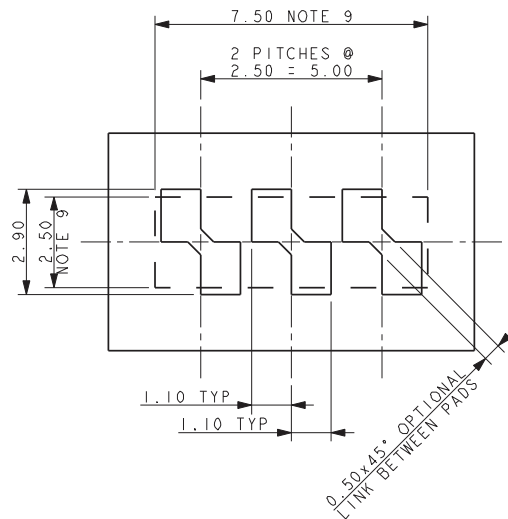

STANDARD 26-28 AWG: 00-9175

Accessory Cap - Through Wire

60-9175-00X-010-X00 ACCESSORY CAP - THROUGH WIRE

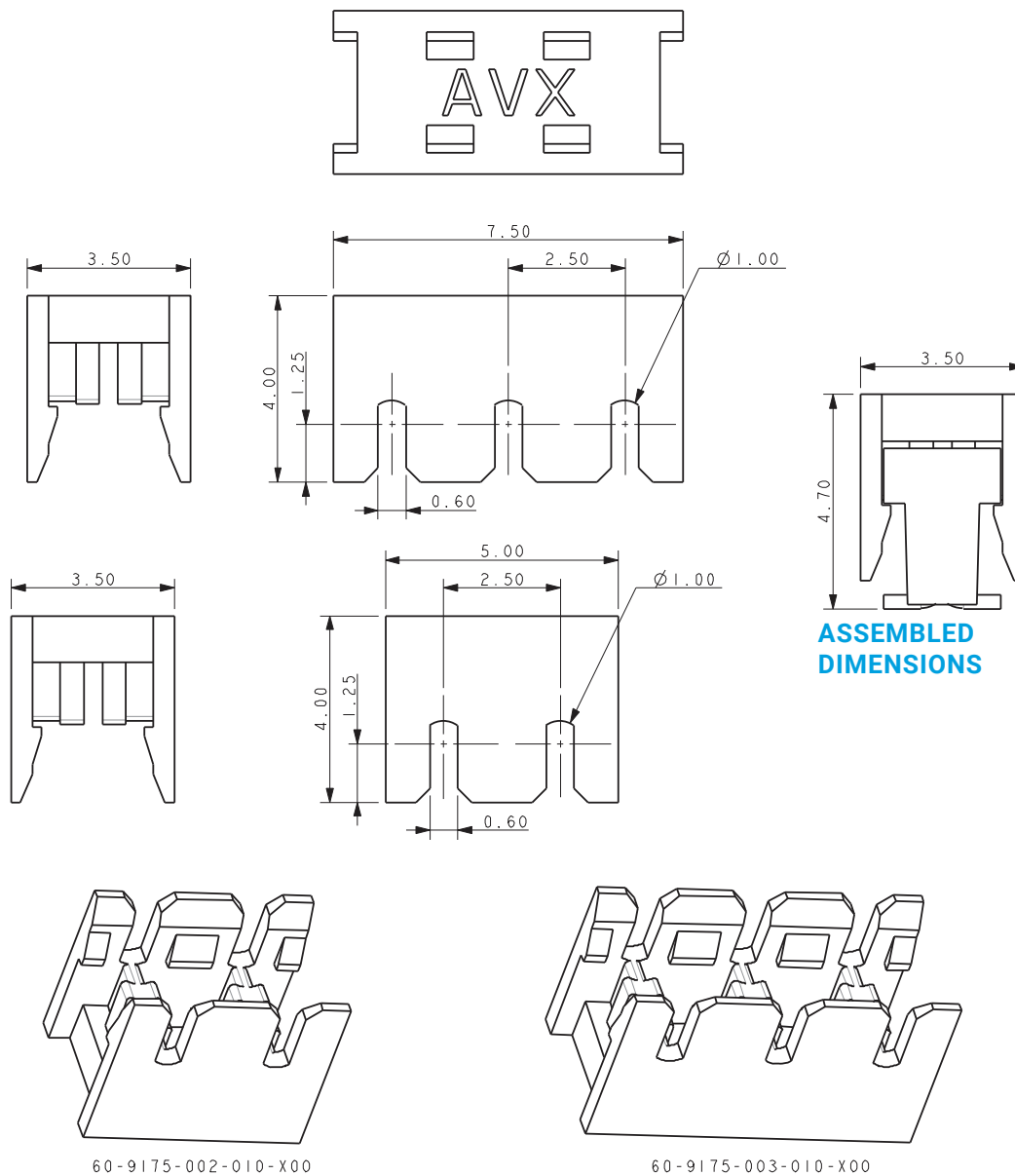

NOTES:

1. CAP FOR IDC WIRE TO BOARD CONNECTION, 2 AND 3 WAY, THROUGH WIRE.
2. THROUGH WIRE CAP CAN BE USED AT ANY POSITION ALONG A WIRE.
3. FOR USE WITH STANDARD 9175 IDC CONNECTORS
4. CAP MATERIAL: GLASS FILLED NYLON 46, FOR COLORS SEE PAGE 3.
5. CAPS DESIGNED TO ACCOMMODATE WIRES WITH INSULATION UP TO 1.00MM DIAMETERS.
6. GENERAL TOLERANCE ± 0.20 .
7. PACKED IN BAGS, 1000 PIECES PER BAG.
8. ALL DIMENSIONS ± 0.20 UNLESS TOLERANCE SPECIFIED.

STANDARD 26-28 AWG: 00-9175

Accessory Cap - Wire Stop

60-9175-00X-0XX-010-X99 ACCESSORY CAP - WIRE STOP

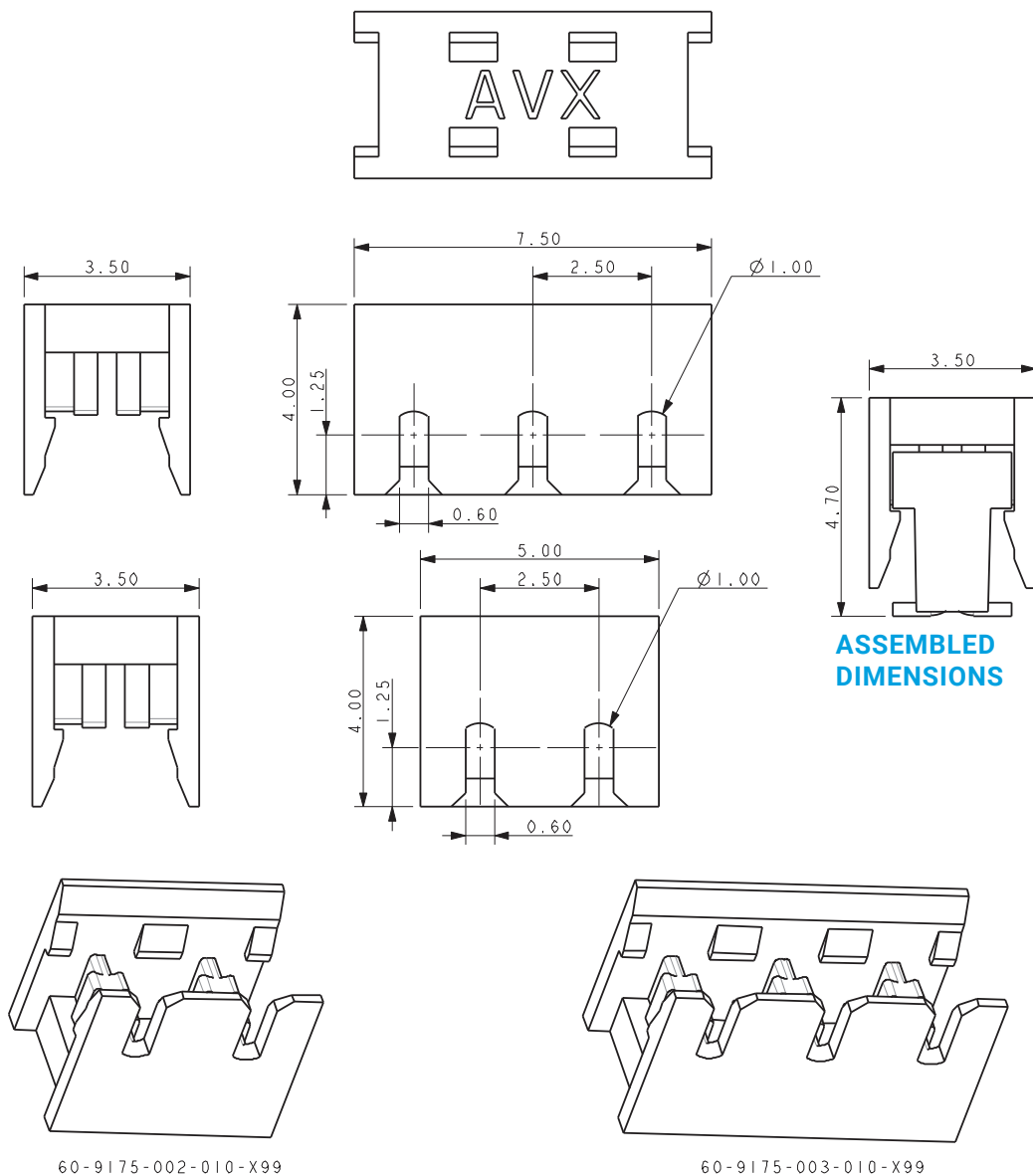

NOTES:

1. CAP FOR IDC WIRE TO BOARD CONNECTION, 2 AND 3 WAY, WIRE STOP.
2. WIRE STOP CAP FOR USE AT WIRE ENDS, STOP FACE PROTECTS THE WIRE ENDS.
3. FOR USE WITH STANDARD 9175 IDC CONNECTORS
4. CAP MATERIAL: GLASS FILLED NYLON 46, FOR COLORS SEE PAGE 3.
5. CAPS DESIGNED TO ACCOMMODATE WIRES WITH INSULATION UP TO 1.00MM DIAMETERS.
6. GENERAL TOLERANCE ± 0.20 .
7. PACKED IN BAGS, 1000 PIECES PER BAG.
8. ALL DIMENSIONS ± 0.20 UNLESS TOLERANCE SPECIFIED.

STANDARD 26-28 AWG: 00-9175

Hand Insertion Tooling / Clearance Area on PCB for Hand Tooling

HAND INSERTION TOOLING SINGLE WIRE INSERTION TOOL FOR 26/28 GAUGE WIRE

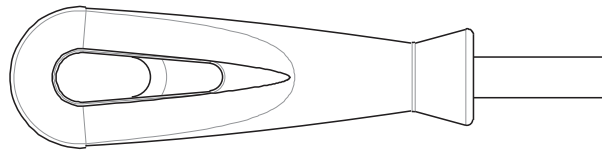

UNIVERSAL HANDLE

Details	Tool Part Number
6.35 A/F HEX BIT HOLDER	06-7000-7730-01-000

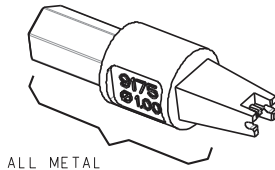

ALL METAL

HIGH PRODUCTION Metal

Max Insulation Dia	Tool Part Number
Ø 1.00	06-9175-7017-01-000



METAL SHANK

PLASTIC

MEDIUM PRODUCTION Metal/Plastic

Max Insulation Dia	Tool Part Number
Ø 1.00	06-9175-7016-01-000

CLEARANCE AREA ON PCB FOR HAND TOOLING

2 WAY

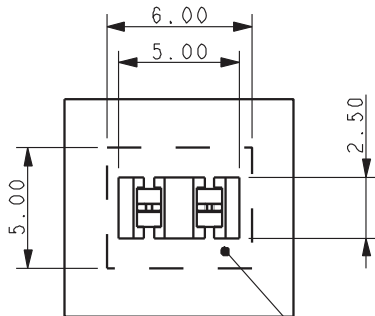

AREA TO BE KEPT CLEAR FOR TOOLING

3 WAY

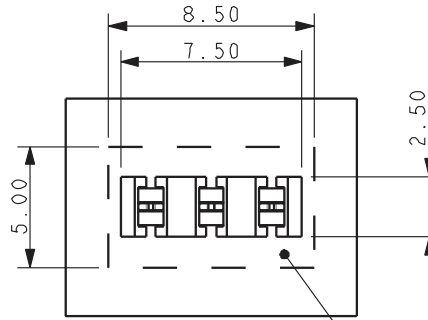

AREA TO BE KEPT CLEAR FOR TOOLING

STANDARD 26-28 AWG: 00-9175

Insertion Tooling Requires Hand Press with Flat Rock Plates

INSERTION TOOLING REQUIRES HAND PRESS WITH FLAT ROCK PLATES

2 WAY TOOL

TOOL NUMBER 06-9175-7017-01-002

SKETCH SHOWS PCB RESTRICTED AREAS FOR ASSEMBLY TOOLING

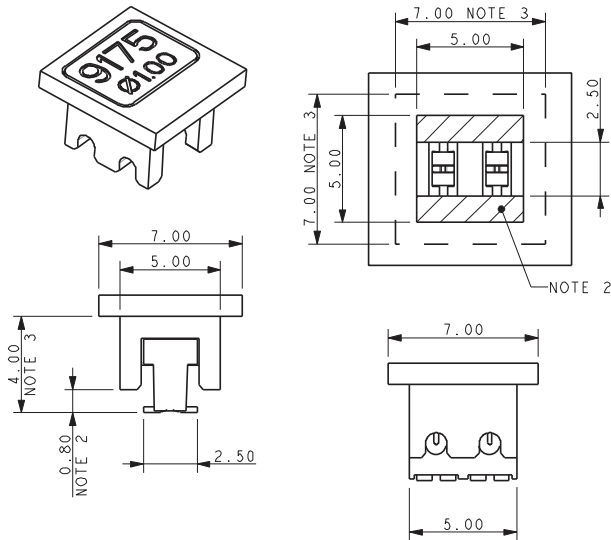

3 WAY TOOL

TOOL NUMBER 06-9175-7017-01-003

SKETCH SHOWS PCB RESTRICTED AREAS FOR ASSEMBLY TOOLING

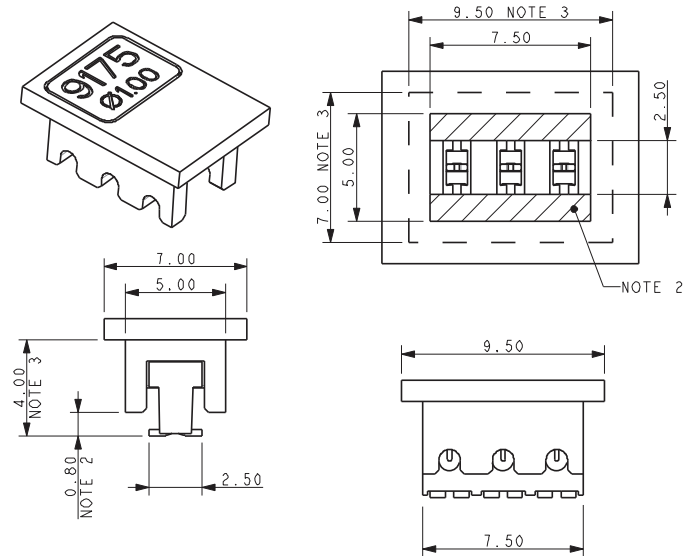

NOTES:

1. DIMENSIONS SHOWN ARE REFERENCE DIMENSIONS.
2. MAXIMUM COMPONENT HEIGHT 0.80MM IN THIS AREA.
3. MAXIMUM COMPONENT HEIGHT 4.00MM IN THIS AREA.
4. THE SAME RESTRICTIONS APPLY TO ALL WIRE INSULATION DIAMETERS.

ASSEMBLED CONNECTOR

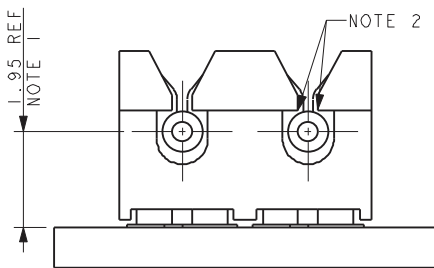

STANDARD CONNECTOR

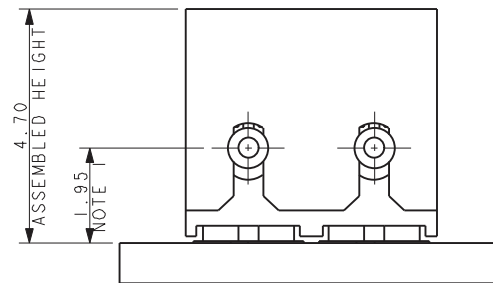

CONNECTOR WITH CAP

NOTES:

1. ASSEMBLED HEIGHTS INCLUDE A 0.10MM ALLOWANCE FOR PAD AND SOLDER THICKNESS, NO ALLOWANCE HAS BEEN MADE FOR ANY SOLDER RESIST OR OTHER FEATURES.
2. WHEN THE WIRE IS ASSEMBLED THE INSULATION SHOULD BE TRAPPED BY THESE EDGES.

CAPPED IDC 26-28 AWG: 9175-700

General Information



The market and applications for simple and reliable discrete Wire-to-Board connectors continue to evolve. KYOCERA AVX first introduced the 9175 series of surface mountable Insulation Displacement Connectors (IDC) in 2006. Developed for harsh industrial and automotive applications, these connectors have been used in hundreds of applications from today's "Smart Meter" all the way down to a simple sensor termination to a PCB. Size and performance has been one of the key factors for selecting this connector in terminating 26-28AWG wires to a PCB.

The next generation of IDC connector moves beyond all of the technical and performance attributes to address the "User Friendliness" of the product. By changing the insulator from acting as a connector body and make it more like a contact carrier, the insulator becomes the wire location and insertion aid without any special tools. The wire is just inserted into the cap (no stripping required) and then pressed down to provide a secure "Gas Tight" termination. This configuration simplifies and cost reduces the entire wire termination process for connecting discrete wires to a PCB.

APPLICATIONS

- Connecting discrete wire components to a PCB
- Bringing power and signals onto a PCB
- Daisy chaining PCB's together to create a continuous string
- Reference Product Specification 201-01-140

FEATURES AND BENEFITS

- IDC contact provides a gas-tight connection to the PCB for long term reliability
- Plastic cap retains the contacts in position prior to automatic placement, then acts as the assembly tool to terminate the wires; no special tooling.
- Tested to automotive levels on shock, vibration and temperature cycling for reliability
- Identical contact and footprint pattern to the existing 9175 for full backward compatibility and functionality
- The IDC contact reduces the total applied cost versus solder or crimp processes
- Connectors are available in two configurations for maximum flexibility; End and Through Wire

ELECTRICAL

- Current Rating: 1 Amps / Contact
- Voltage Rating: 150 VAC

ENVIRONMENTAL

- Operating Temperature: -40°C to +125°C

MECHANICAL

- Insulator Material: Nylon UL94VO
- Contact Material: Phosphor Bronze
- Plating: Tin over Nickel

HOW TO ORDER

Prefix	Series	Number of Ways	
00	9175	00X	
Code	No of Ways	Details	
002	2	Pages 11 & 13	
003	3	Pages 12 & 14	

Wire Gauge Size Cap Pre-Assembled		
Code	Accepted Wire Gauge	Wire Insulation
701	28 Gauge Solid or Stranded	Min Ø 0.70 Max Ø 1.00
702	26 Gauge Solid or Stranded	Min Ø 0.80 Max Ø 1.20

Insulator Color	
9 =	UL White
8 =	UL Black
	Special Order

Cap Options			
Code	Cap Option	Description	Detail
0	Through Wire	Allows wire to be terminated at any point	Page 11-12
9	Wire Stop	Terminates end of wire End Protected by stop face	Pages 13-14

Plating Option	
6 =	Pure Tin all over

Certification: UL File #E90723



CAPPED IDC 26-28 AWG: 9175-700

2 Position - Through Wire

26-28 AWG 2 WAY IDC CONNECTOR THROUGH WIRE CAPPED IDC

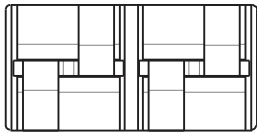
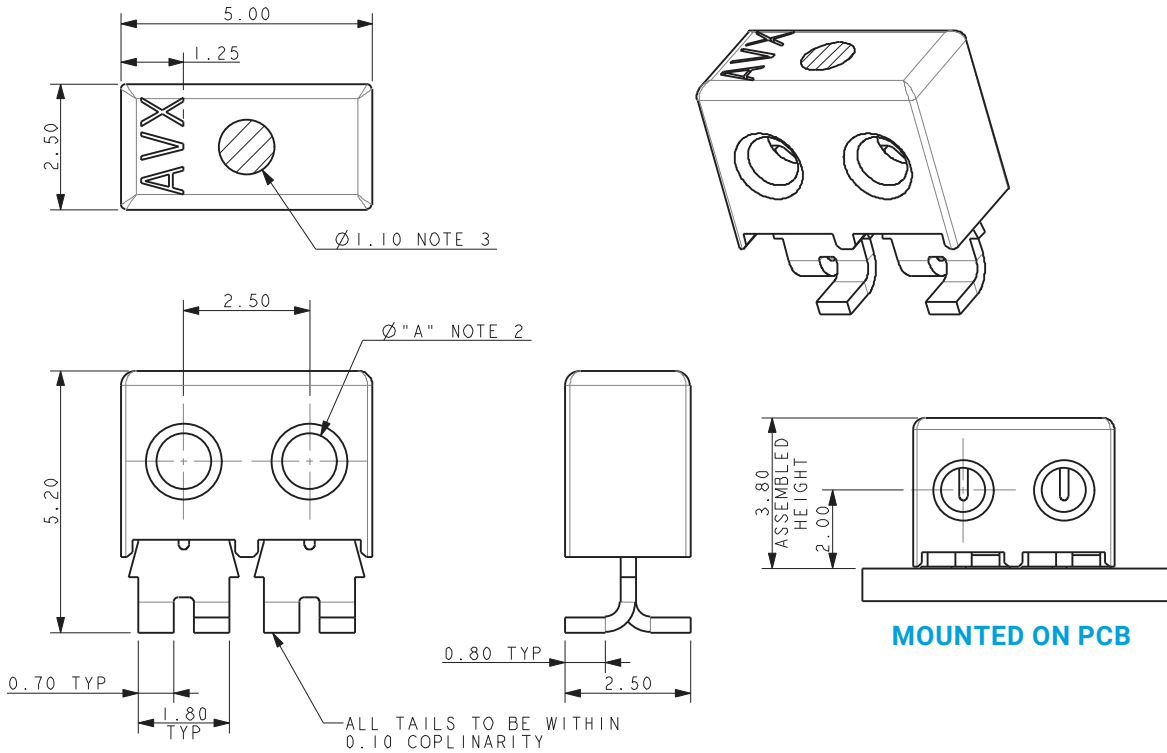

Code	Wire Gauge	Diameter A
701	28AWG	1.10
702	26AWG	1.30

NOTES:

- 2 WAY CONNECTOR FOR IDC WIRE TO BOARD CONNECTION. PRE-ASSEMBLED THROUGH WIRE CAP.
- CONTACT/CAP TO MATCH 26AWG AND 28AWG WIRES. SOLID OR STRANDED CONDUCTOR. MAXIMUM INSULATOR 1.00 MM DIAMETER.
- FLAT FACE ON TOP OF CAP TO AID PICK AND PLACE ASSEMBLY.
- FOR FULL PRODUCT SPECIFICATION ON STANDARD CONNECTORS REFER TO ELCO SPEC 201-01-139. UL COMPONENTS REFER TO ELCO SPEC 201-01-139UL.
- ASSEMBLY PROCEDURE, REFER TO APPLICATION NOTES 201-01-140.
- GENERAL TOLERANCE ± 0.20 UNLESS STATED.
- PACKED IN TAPE AND REEL, QUANTITY PER REEL 1000.
- CONNECTOR OUTLINE.
- CONTACT MATERIAL: TIN PLATED COPPER ALLOY.
- INSULATOR MATERIAL: HIGH TEMPERATURE NYLON, GLASS FILLED, UL94 V-0. COLOR REFER TO PAGE 10.
- FOR UL CODES UL REFERENCE E90723 (US AND CANADA).

PACKING DETAILS

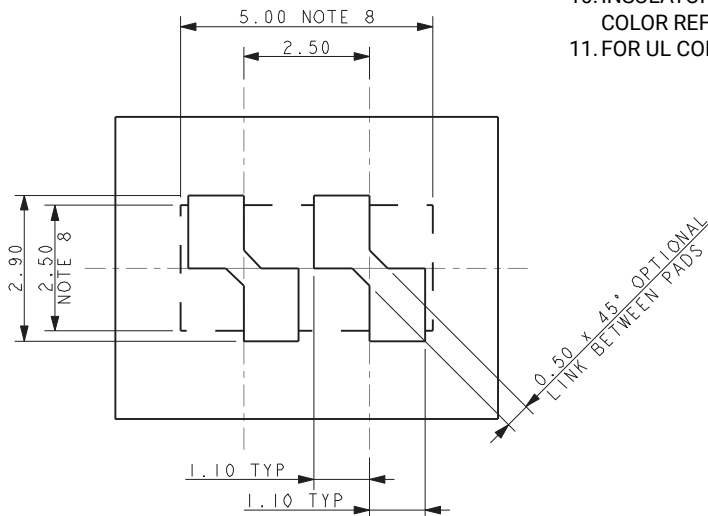

SUGGEST PCB LAYOUT

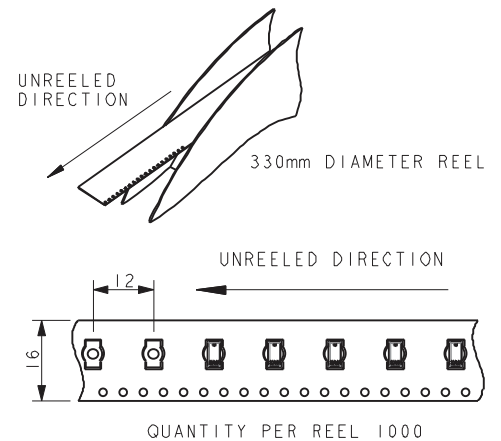

CAPPED IDC 26-28 AWG: 9175-700

3 Position - Through Wire

26-28 AWG 3 WAY IDC CONNECTOR THROUGH WIRE CAPPED IDC

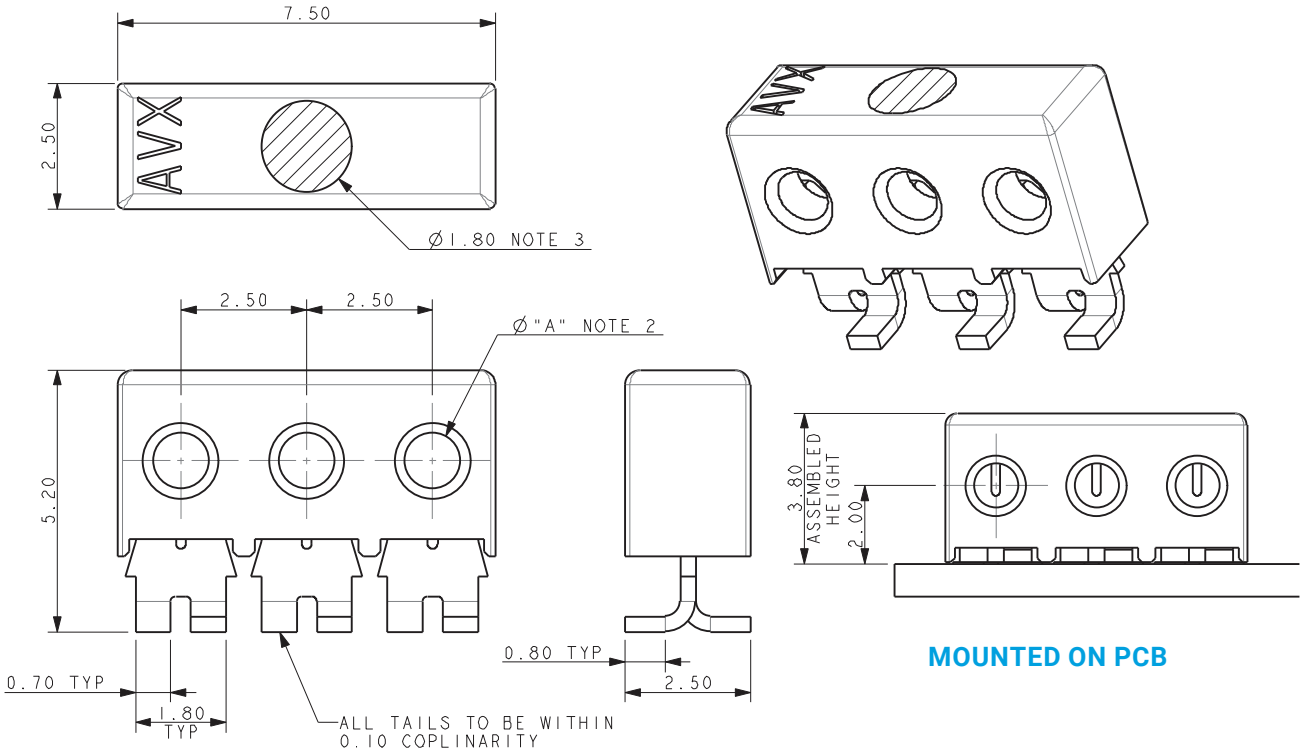

MOUNTED ON PCB

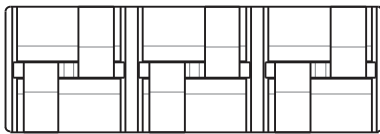

Code	Wire Gauge	Diameter A
701	28AWG	1.10
702	26AWG	1.30

NOTES:

1. WAY CONNECTOR FOR IDC WIRE TO BOARD CONNECTION. PRE-ASSEMBLED THROUGH WIRE CAP.
2. CONTACT/CAP TO MATCH 26AWG AND 28AWG WIRES. SOLID OR STRANDED CONDUCTOR. MAXIMUM INSULATOR 1.00 MM DIAMETER.
3. FLAT FACE ON TOP OF CAP TO AID PICK AND PLACE ASSEMBLY.
4. FOR FULL PRODUCT SPECIFICATION ON STANDARD CONNECTORS REFER TO ELCO SPEC 201-01-139. UL COMPONENTS REFER TO ELCO SPEC 201-01-139UL.
5. ASSEMBLY PROCEDURE, REFER TO APPLICATION NOTES 201-01-140.
6. GENERAL TOLERANCE ± 0.20 UNLESS STATED.
7. PACKED IN TAPE AND REEL, QUANTITY PER REEL 1000.
8. CONNECTOR OUTLINE.
9. CONTACT MATERIAL: TIN PLATED COPPER ALLOY.
10. INSULATOR MATERIAL: HIGH TEMPERATURE NYLON, GLASS FILLED, UL94 V-0. COLOR REFER TO PAGE 10.
11. FOR UL CODES UL REFERENCE E90723 (US AND CANADA).

PACKING DETAILS

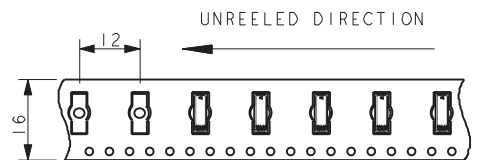
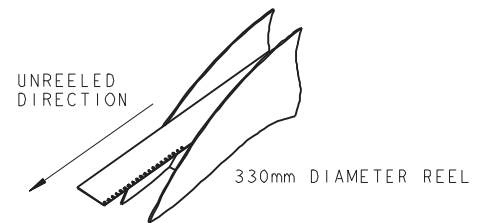

QUANTITY PER REEL 1000

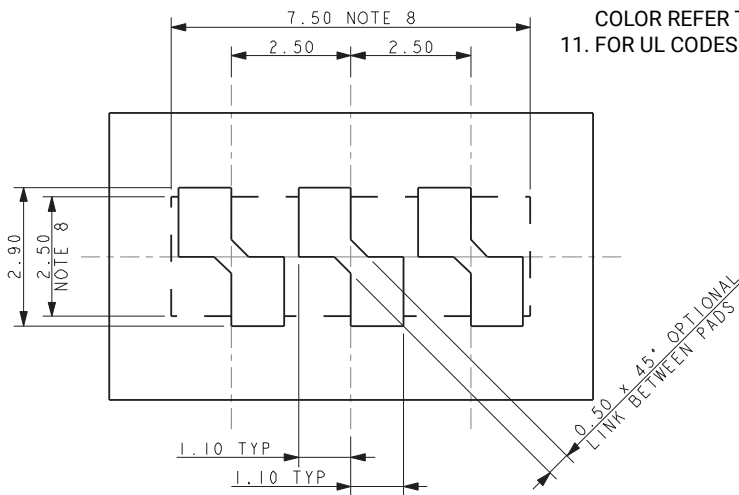

SUGGEST PCB LAYOUT

CAPPED IDC 26-28 AWG: 9175-700

2 Position - Wire Stop

26-28 AWG 2 WAY IDC CONNECTOR WIRE STOP CAPPED IDC

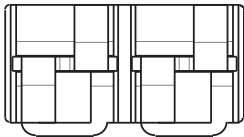
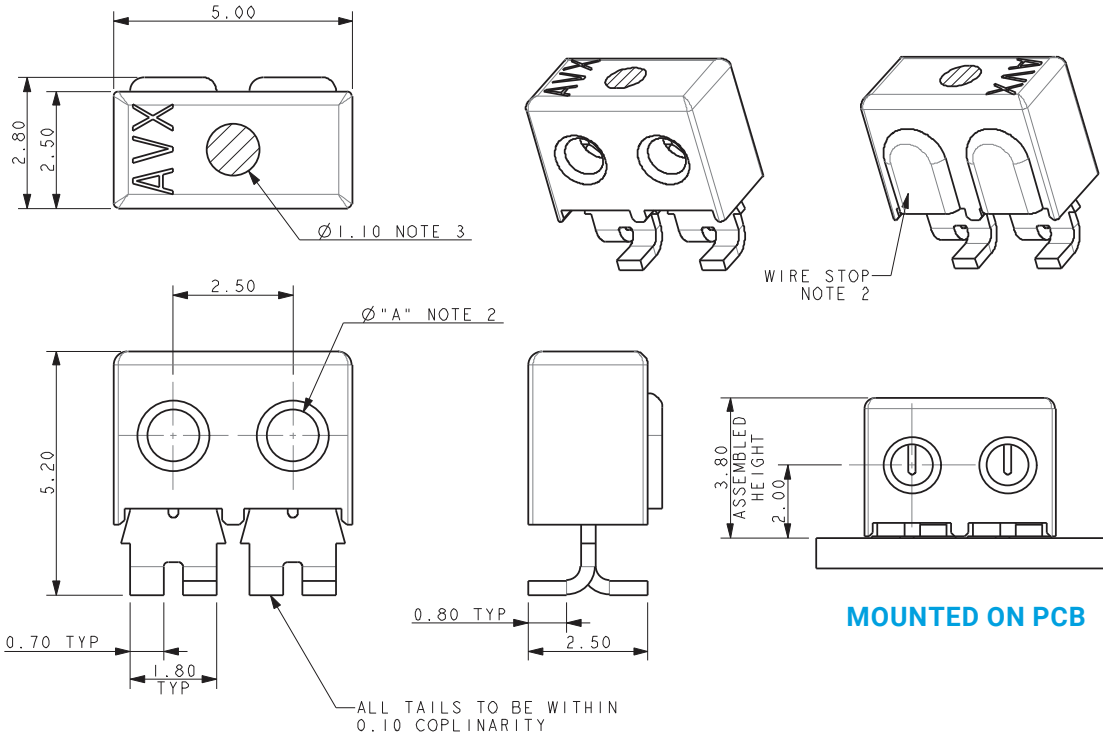

Code	Wire Gauge	Diameter A
701	28AWG	1.10
702	26AWG	1.30

NOTES:

- 2 WAY CONNECTOR FOR IDC WIRE TO BOARD CONNECTION. PRE-ASSEMBLED WIRE STOP CAP.
- WIRE STOP CAP PROTECTS END OF WIRE.
- CONTACT/CAP TO MATCH 26AWG AND 28AWG WIRES. SOLID OR STRANDED CONDUCTOR. MAXIMUM INSULATOR 1.00 MM DIAMETER.
- FLAT FACE ON TOP OF CAP TO AID PICK AND PLACE ASSEMBLY.
- FOR FULL PRODUCT SPECIFICATION ON STANDARD CONNECTORS REFER TO ELCO SPEC 201-01-139. UL COMPONENTS REFER TO ELCO SPEC 201-01-139UL.
- ASSEMBLY PROCEDURE, REFER TO APPLICATION NOTES 201-01-140.
- GENERAL TOLERANCE ± 0.20 UNLESS STATED.
- PACKED IN TAPE AND REEL, QUANTITY PER REEL 1000.
- CONNECTOR OUTLINE.
- CONTACT MATERIAL: TIN PLATED COPPER ALLOY.
- INSULATOR MATERIAL: HIGH TEMPERATURE NYLON, GLASS FILLED, UL94 V-0. COLOR REFER TO PAGE 10.
- FOR UL CODES UL REFERENCE E90723 (US AND CANADA).

PACKING DETAILS

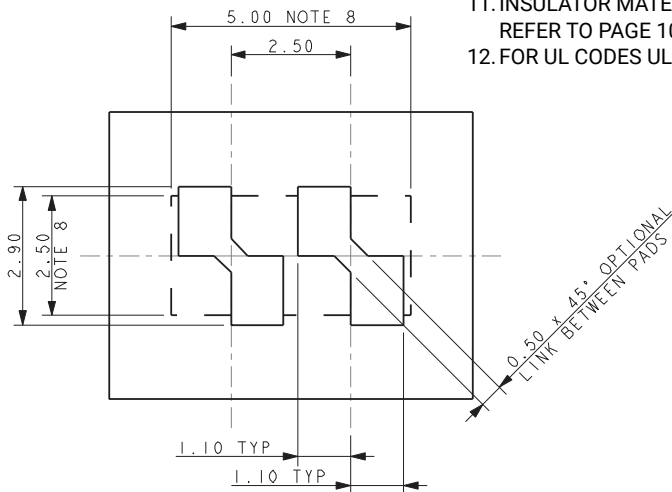

SUGGEST PCB LAYOUT

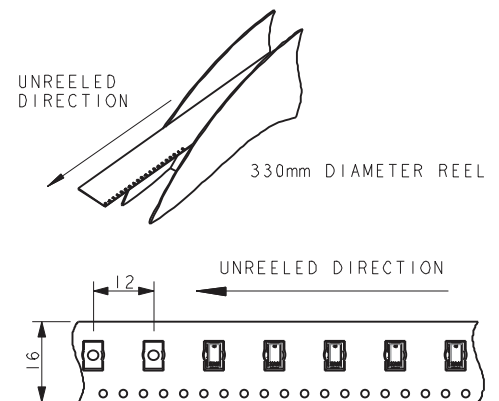

CAPPED IDC 26-28 AWG: 9175-700

3 Position - Wire Stop

26-28 AWG 3 WAY IDC CONNECTOR WIRE STOP CAPPED IDC

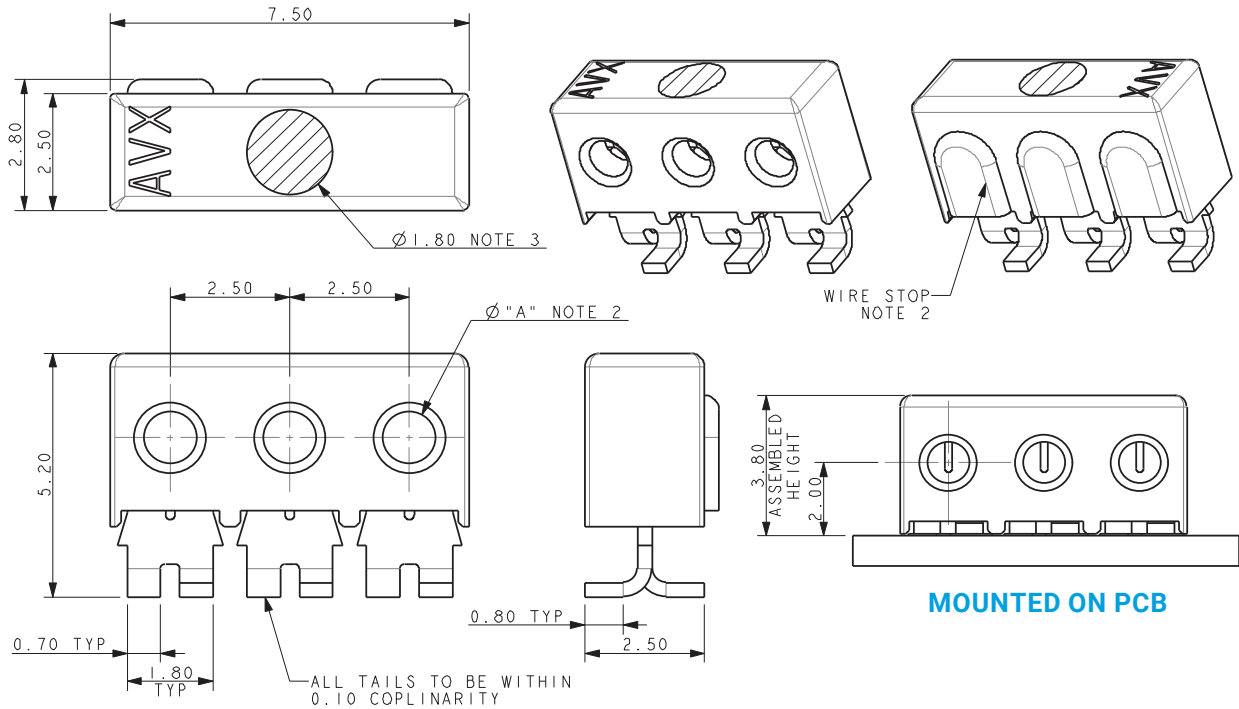

MOUNTED ON PCB

NOTES:

- 3 WAY CONNECTOR FOR IDC WIRE TO BOARD CONNECTION. PRE-ASSEMBLED WIRE STOP CAP.
- WIRE STOP CAP PROTECTS END OF WIRE.
- CONTACT/CAP TO MATCH 26AWG AND 28AWG WIRES. SOLID OR STRANDED CONDUCTOR. MAXIMUM INSULATOR 1.00 MM DIAMETER.
- FLAT FACE ON TOP OF CAP TO AID PICK AND PLACE ASSEMBLY.
- FOR FULL PRODUCT SPECIFICATION ON STANDARD CONNECTORS REFER TO ELCO SPEC 201-01-139. UL COMPONENTS REFER TO ELCO SPEC 201-01-139UL.
- ASSEMBLY PROCEDURE, REFER TO APPLICATION NOTES 201-01-140.
- GENERAL TOLERANCE ± 0.20 UNLESS STATED.
- PACKED IN TAPE AND REEL, QUANTITY PER REEL 1000.
- CONNECTOR OUTLINE.
- CONTACT MATERIAL: TIN PLATED COPPER ALLOY.
- INSULATOR MATERIAL: HIGH TEMPERATURE NYLON, GLASS FILLED, UL94 V-0. COLOR REFER TO PAGE 10.
- FOR UL CODES UL REFERENCE E90723 (US AND CANADA).

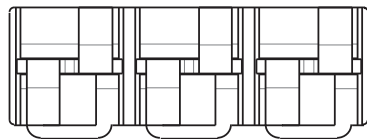

Code	Wire Gauge	Diameter A
701	28AWG	1.10
702	26AWG	1.30

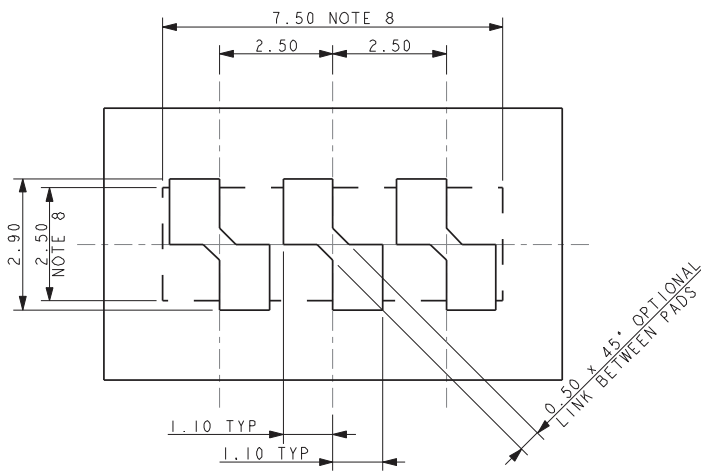

SUGGEST PCB LAYOUT

PACKING DETAILS

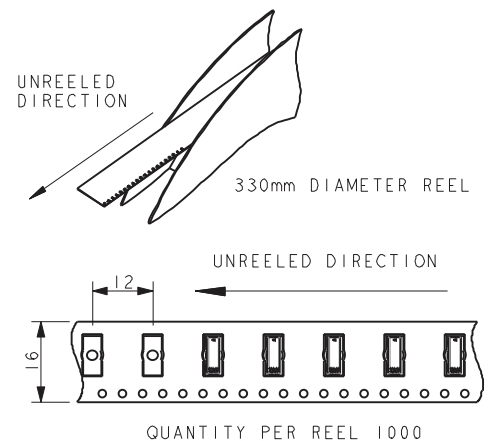

CAPPED IDC 26-28 AWG: 9175-700

Assembly - Through Wire and Wire Stop

26-28 AWG ASSEMBLED CAPPED IDC CONNECTORS

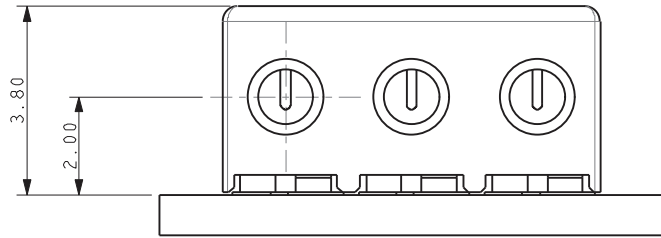

MOUNTED ON PCB

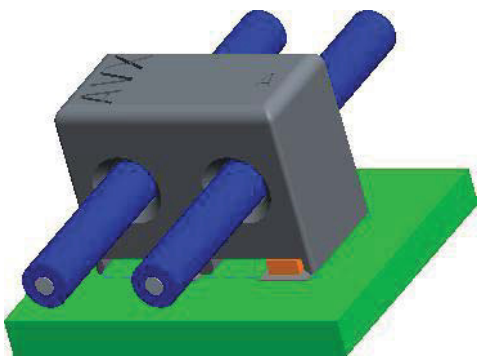

TYPICAL THROUGH WIRE ASSEMBLY

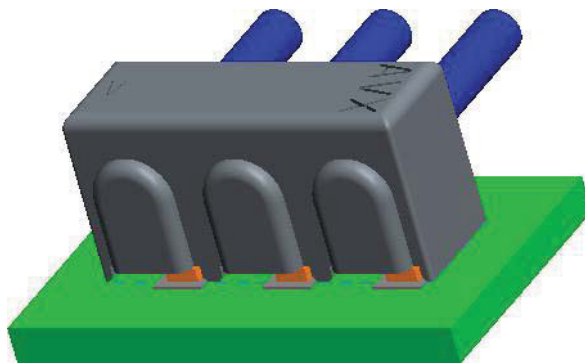
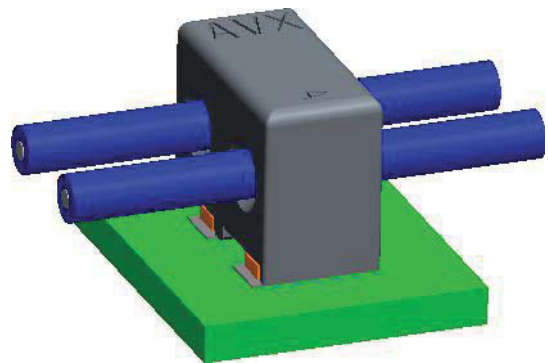

TYPICAL WIRE STOP ASSEMBLY

STANDARD IDC 18-24 AWG: 00-9176

General Information

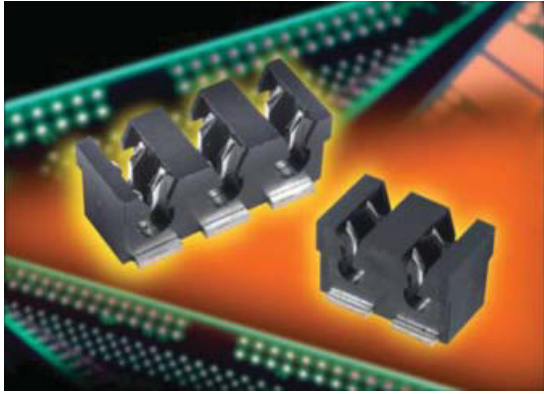

The 917X series of surface mount Insulation Displacement Connectors (IDC) were developed to meet the harsh automotive and industrial market applications for connecting individual wires directly to a PCB ranging from 14 AWG to 28 AWG. This industry proven contact system has been tested to automotive levels of shock, vibration, and temperature cycling to prove their reliability and robustness. The simplicity of inserting a wire into the connector with a small tool allows a wide range of devices to be connected to the PCB without soldering. In SSL applications specifically, these connectors are used to bring power and signal onto the PCB or are used to daisy chain multiple boards together in a long string. While the IDC contact provides a gas-tight connection to conductor of the wire, the housing has been designed to grab the insulation of the wire to provide a positive strain relief even in the harshest conditions. In case of repair, the wires can be removed and replace up to three times.

The 9176 series accepts 18 AWG to 24 AWG wires with an insulation diameter ranging from 1.1mm to 2.1mm. These dual contact connectors support a 10 amp current rating with two large SMT solder tails per wire to provide maximum stability on the PCB. Available in 1p-3p configuration, these connectors can be end stackable for higher pin counts. The 9176 series also comes with optional locking strain relief caps that act as the termination tool for severe vibration applications.

APPLICATIONS

- Connecting discrete wire components directly to the PCB
- Bringing power and signals onto a PCB
- Daisy chaining PCB's together to create a continuous string of boards
- Application Notes: refer to 201-01-124

FEATURES AND BENEFITS

- IDC contact provides a gas-tight connection to the PCB for long term reliability
- Connector housing captures the wire insulation for positive strain relief
- Tested to automotive levels on shock, vibration and temperature cycling for reliability
- Low and high volume assembly tools to match production volumes
- Reduced total applied cost versus solder or crimp processes
- Optional thru and end caps lock in place to provide maximum strain relief
- High temperature insulator capable to 260°C reflow soldering processes

ELECTRICAL

- Current Rating: 10 Amp / Contact
- Voltage Rating: 300 VAC

ENVIRONMENTAL

- Operating Temperature: -40°C to +125°C

MECHANICAL

- Insulator Material: Nylon 46: UL94V0
- Contact Material: Phosphor Bronze
- Plating: Tin over Nickel
- Durability: 3 Cycles

HOW TO ORDER

00

Prefix

9175

Series

00X

Number of Ways
001 = 1
002 = 2
003 = 3

0XX

Wire Gauge Size

Code	Accepted Wire Gauge	Wire Insulation	Cap Code Pages 21-22
001	18 Gauge Stranded	Ø 1.6-2.1	021
011	20 Gauge Solid or Stranded	Ø 1.6-2.1	021
022	22 Gauge Solid or Stranded	Ø 1.1-1.6	016
032	24 Gauge Solid or Stranded	Ø 1.1-1.6	016

X

Insulator Color

All Sizes
9 = UL White (Standard)
8 = UL Black (Special Order)

One Way Only (Special Order)

2 = UL Brown
3 = UL Blue
4 = UL Yellow
5 = UL Red
6 = UL Green
7 = UL Orange

06

Plating

Option
6 = Pure Tin all over



Certification: UL File #E90723

STANDARD IDC 18-24 AWG: 00-9176

General Information

CONNECTOR/TOOLING PART NUMBER MATRIX

SERIES 9176 IDC					HAND INSERTION TOOLING*			ACCESSORY CAPS	
AWG	Wire Insulation	Positions	Color	Part Number	Plastic (medium volume)	Metal (high volume)	Mass Termination	Though Wire	Wire Stop
18	Ø 1.6 - 2.1	1p	Black	009176001001806	069176701601000	069176701701000	N/A	609176001021000	609176001021099
18	Ø 1.6 - 2.1	1p	White	009176001001906	069176701601000	069176701701000	N/A	609176001021100	609176001021199
18	Ø 1.6 - 2.1	2p	Black	009176002001806	069176701601000	069176701701000	069176701701002	609176002021000	609176002021099
18	Ø 1.6 - 2.1	2p	White	009176002001906	069176701601000	069176701701000	069176701701002	609176002021100	609176002021199
18	Ø 1.6 - 2.1	3p	Black	009176003001806	069176701601000	069176701701000	069176701701003	609176003021000	609176003021099
18	Ø 1.6 - 2.1	3p	White	009176003001906	069176701601000	069176701701000	069176701701003	609176003021100	609176003021199
20	Ø 1.6 - 2.1	1p	Black	009176001011806	069176701601000	069176701701000	N/A	609176001021000	609176001021099
20	Ø 1.6 - 2.1	1p	White	009176001011906	069176701601000	069176701701000	N/A	609176001021100	609176001021199
20	Ø 1.6 - 2.1	2p	Black	009176002011806	069176701601000	069176701701000	069176701701002	609176002021000	609176002021099
20	Ø 1.6 - 2.1	2p	White	009176002011906	069176701601000	069176701701000	069176701701002	609176002021100	609176002021199
20	Ø 1.6 - 2.1	3p	Black	009176003011806	069176701601000	069176701701000	069176701701003	609176003021000	609176003021099
20	Ø 1.6 - 2.1	3p	White	009176003011906	069176701601000	069176701701000	069176701701003	609176003021100	609176003021199
22	Ø 1.1 - 1.6	1p	Black	009176001022806	069176701602000	069176701702000	N/A	609176001016000	609176001016099
22	Ø 1.1 - 1.6	1p	White	009176001022906	069176701602000	069176701702000	N/A	609176001016100	609176001016199
22	Ø 1.1 - 1.6	2p	Black	009176002022806	069176701602000	069176701702000	069176701702002	609176002016000	609176002016099
22	Ø 1.1 - 1.6	2p	White	009176002022906	069176701602000	069176701702000	069176701702002	609176002016100	609176002016199
22	Ø 1.1 - 1.6	3p	Black	009176003022806	069176701602000	069176701702000	069176701702003	609176003016000	609176003016099
22	Ø 1.1 - 1.6	3p	White	009176003022906	069176701602000	069176701702000	069176701702003	609176003016100	609176003016199
24	Ø 1.1 - 1.6	1p	White	009176001032106	069176701602000	069176701702000	N/A	609176001016100	609176001016199
24	Ø 1.1 - 1.6	1p	Black	009176001032806	069176701602000	069176701702000	N/A	609176001016000	609176001016099
24	Ø 1.1 - 1.6	1p	White	009176001032906	069176701602000	069176701702000	N/A	609176001016100	609176001016199
24	Ø 1.1 - 1.6	2p	Black	009176002032806	069176701602000	069176701702000	069176701702002	609176002016000	609176002016099
24	Ø 1.1 - 1.6	2p	White	009176002032906	069176701602000	069176701702000	069176701702002	609176002016100	609176002016199
24	Ø 1.1 - 1.6	3p	Black	009176003032806	069176701602000	069176701702000	069176701702003	609176003016000	609176003016099
24	Ø 1.1 - 1.6	3p	White	009176003032906	069176701602000	069176701702000	069176701702003	609176003016100	609176003016199

* Hand Insertion Tooling - Universal Hand Tool 067000773001000; Consult Application Notes 201-01-124

STANDARD IDC 18-24 AWG: 00-9176

1 Position

18-24 AWG 1 WAY IDC CONNECTOR

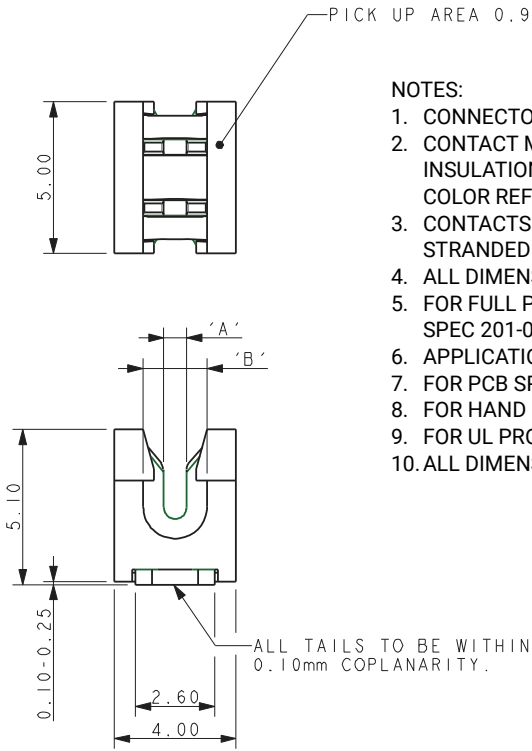

NOTES:

1. CONNECTOR FOR IDC WIRE TO BOARD CONNECTION.
2. CONTACT MATERIAL: PHOSPHOR BRONZE.
INSULATION MATERIAL: HIGH TEMPERATURE NYLON 46.
COLOR REFER TO PAGE 16.
3. CONTACTS DESIGNED TO ACCEPT BETWEEN 20AWG AND 24AWG SOLID AND STRANDED WIRES. 18AWG WILL ONLY ACCEPT STRANDED WIRES, SEE TABLE.
4. ALL DIMENSIONS FOR REFERENCE UNLESS OTHERWISE STATED.
5. FOR FULL PRODUCT SPECIFICATION ON STANDARD CONNECTORS REFER TO ELCO SPEC 201-01-106. UL COMPONENTS REFER TO ELECO SPEC 201-01-106U.
6. APPLICATION NOTES 201-01-124.
7. FOR PCB SPACE RESTRICTED BY WIRE ASSEMBLY TOOLING REFER TO PAGE 23.
8. FOR HAND WIRE ASSEMBLY TOOLING REFER TO PAGE 23.
9. FOR UL PRODUCT CODES UL REFERENCE E90723 (US AND CANADA).
10. ALL DIMENSIONS ± 0.20 TOLERANCE SPECIFIED.

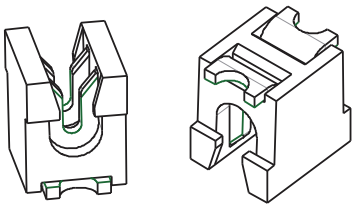
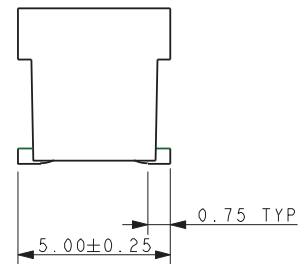

Code	Accepted Wire Gauge	A	Wire Insulation	B
001	18AWG Stranded	0.72	Ø1.6-2.1	2.1
011	20AWG Solid and Stranded	0.60	Ø1.6-2.1	2.1
022	22AWG Solid and Stranded	0.47	Ø1.1-1.6	1.6
032	24AWG Solid and Stranded	0.37	Ø1.1-1.6	1.6

SMT PCB LAYOUT

PURE TIN PADS

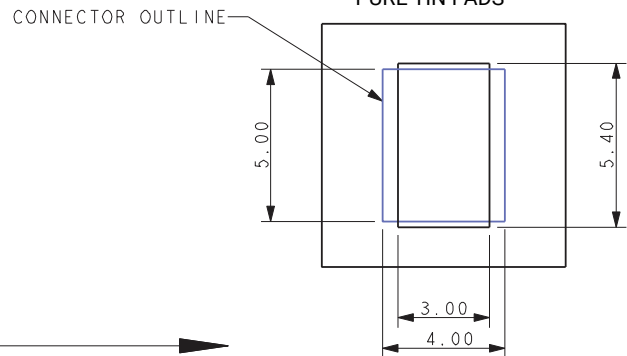

PACKING DETAILS

REEL QTY	1000
LEADER	480MM
TRAILER	120MM

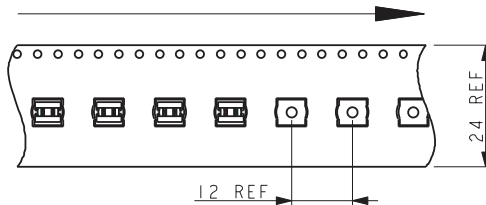
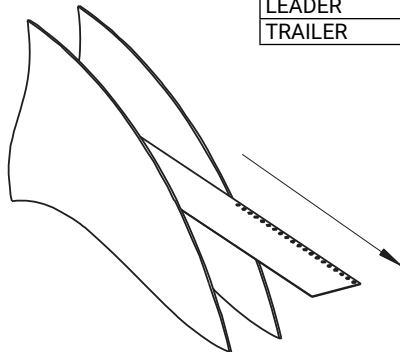

STANDARD IDC 18-24 AWG: 00-9176

2 Position

18-24 AWG 2 WAY IDC CONNECTOR

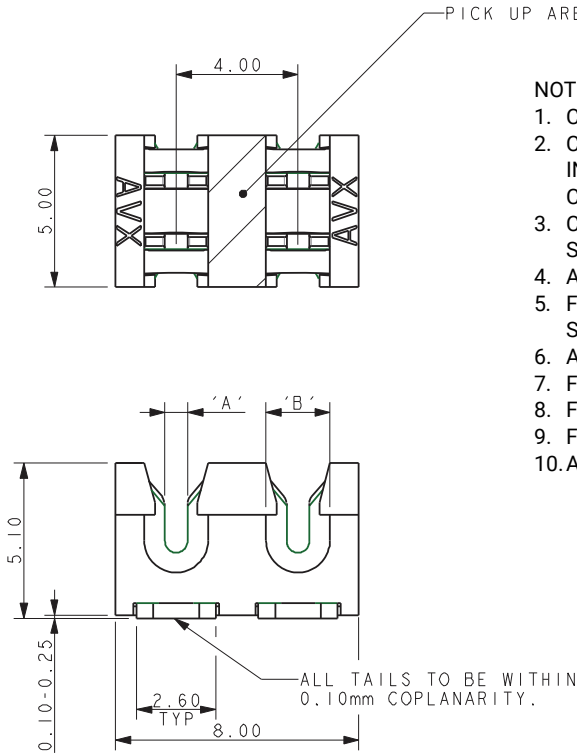

NOTES:

- CONNECTOR FOR IDC WIRE TO BOARD CONNECTION.
- CONTACT MATERIAL: PHOSPHOR BRONZE.
INSULATION MATERIAL: HIGH TEMPERATURE NYLON 46.
COLOR REFER TO PAGE 16.
- CONTACTS DESIGNED TO ACCEPT BETWEEN 20AWG AND 24AWG SOLID AND STRANDED WIRES. 18AWG WILL ONLY ACCEPT STRANDED WIRES, SEE TABLE.
- ALL DIMENSIONS FOR REFERENCE UNLESS OTHERWISE STATED.
- FOR FULL PRODUCT SPECIFICATION ON STANDARD CONNECTORS REFER TO ELCO SPEC 201-01-106. UL COMPONENTS REFER TO ELECO SPEC 201-01-106J.
- APPLICATION NOTES 201-01-124.
- FOR PCB SPACE RESTRICTED BY WIRE ASSEMBLY TOOLING REFER TO PAGE 23.
- FOR HAND WIRE ASSEMBLY TOOLING REFER TO PAGE 23.
- FOR UL PRODUCT CODES UL REFERENCE E90723 (US AND CANADA).
- ALL DIMENSIONS ± 0.20 TOLERANCE SPECIFIED.

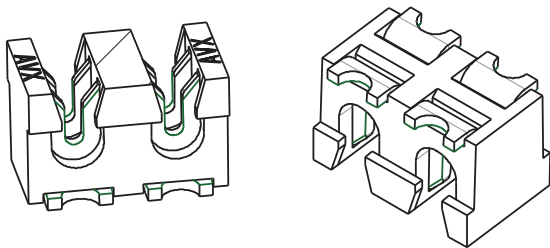
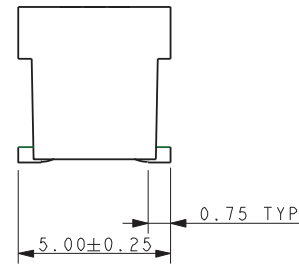

Code	Accepted Wire Gauge	A	Wire Insulation	B
001	18AWG Stranded	0.72	Ø1.6-2.1	2.1
011	20AWG Solid and Stranded	0.60	Ø1.6-2.1	2.1
022	22AWG Solid and Stranded	0.47	Ø1.1-1.6	1.6
032	24AWG Solid and Stranded	0.37	Ø1.1-1.6	1.6

SMT PCB LAYOUT PURE TIN PADS

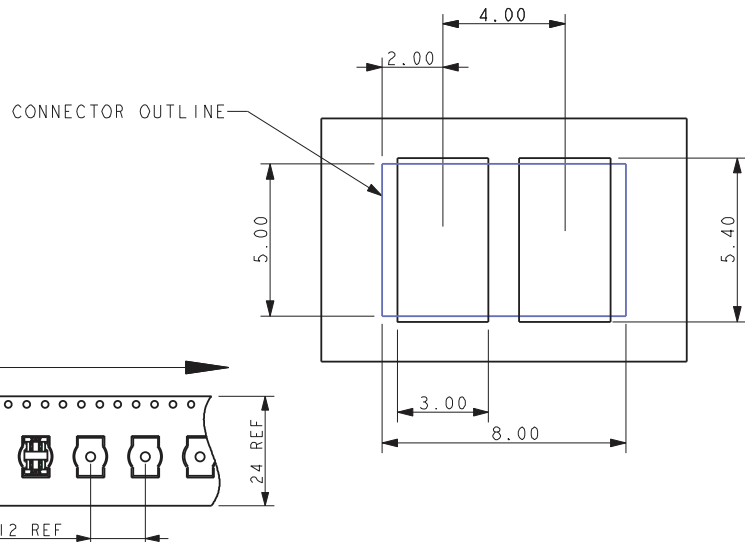

PACKING DETAILS

REEL QTY	1000
LEADER	480MM
TRAILER	120MM

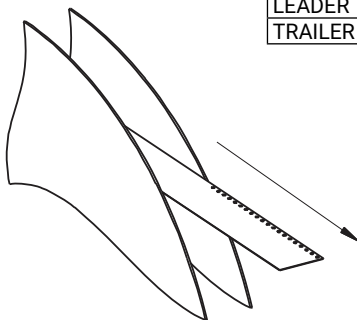

STANDARD IDC 18-24 AWG: 00-9176

3 Position

18-24 AWG 3 WAY IDC CONNECTOR

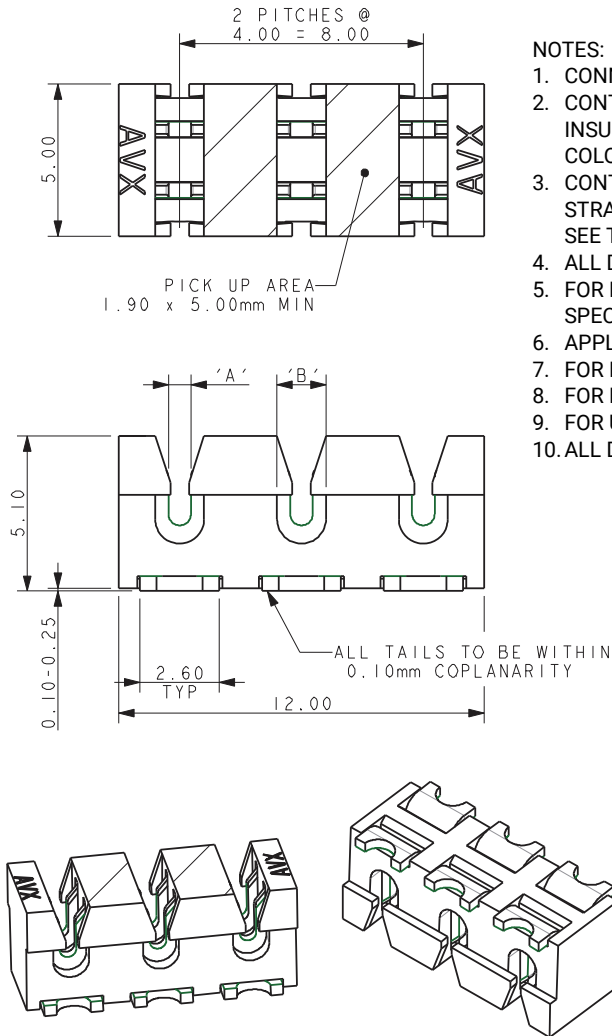

NOTES:

- CONNECTOR FOR IDC WIRE TO BOARD CONNECTION.
- CONTACT MATERIAL: PHOSPHOR BRONZE.
INSULATION MATERIAL: HIGH TEMPERATURE NYLON 46.
COLOR REFER TO PAGE 16.
- CONTACTS DESIGNED TO ACCEPT BETWEEN 20AWG AND 24AWG SOLID AND STRANDED WIRES. 18AWG WILL ONLY ACCEPT STRANDED WIRES, SEE TABLE.
- ALL DIMENSIONS FOR REFERENCE UNLESS OTHERWISE STATED.
- FOR FULL PRODUCT SPECIFICATION ON STANDARD CONNECTORS REFER TO ELCO SPEC 201-01-106. UL COMPONENTS REFER TO ELECO SPEC 201-01-106U.
- APPLICATION NOTES 201-01-124.
- FOR PCB SPACE RESTRICTED BY WIRE ASSEMBLY TOOLING REFER TO PAGE 23.
- FOR HAND WIRE ASSEMBLY TOOLING REFER TO PAGE 23.
- FOR UL PRODUCT CODES UL REFERENCE E90723 (US AND CANADA).
- ALL DIMENSIONS ± 0.20 TOLERANCE SPECIFIED.

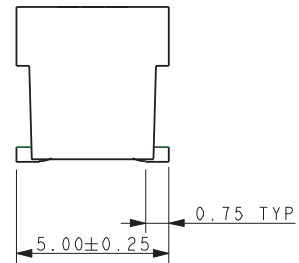

Code	Accepted Wire Gauge	A	Wire Insulation	B
001	18AWG Stranded	0.72	Ø1.6-2.1	2.1
011	20AWG Solid and Stranded	0.60	Ø1.6-2.1	2.1
022	22AWG Solid and Stranded	0.47	Ø1.1-1.6	1.6
032	24AWG Solid and Stranded	0.37	Ø1.1-1.6	1.6

SMT PCB LAYOUT

PURE TIN PADS

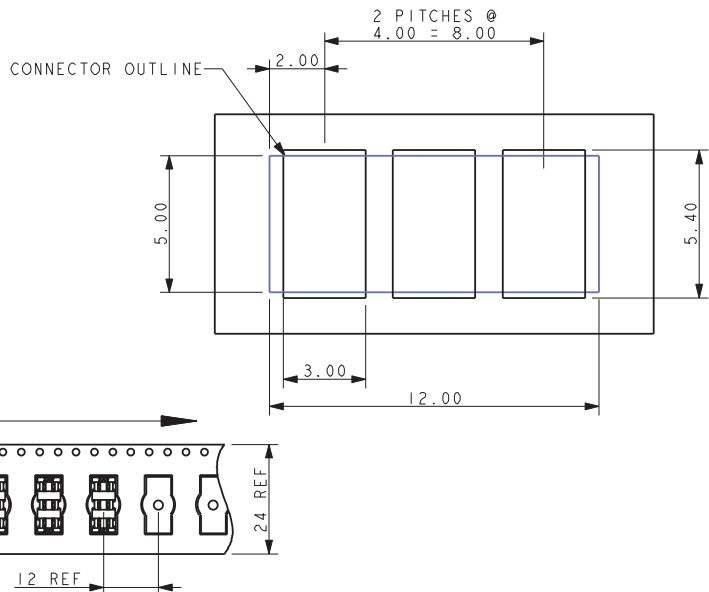

PACKING DETAILS

REEL QTY	1000
LEADER	480MM
TRAILER	120MM

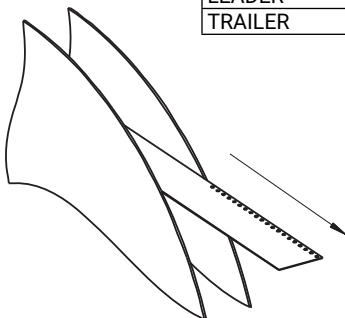

STANDARD IDC 18-24 AWG: 00-9176

Accessory Cap - Through Wire

60-9176-00X-0XX-X00 ACCESSORY CAP - THROUGH WIRE

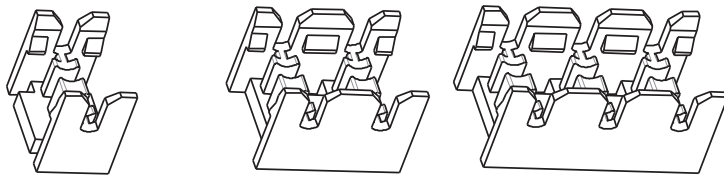
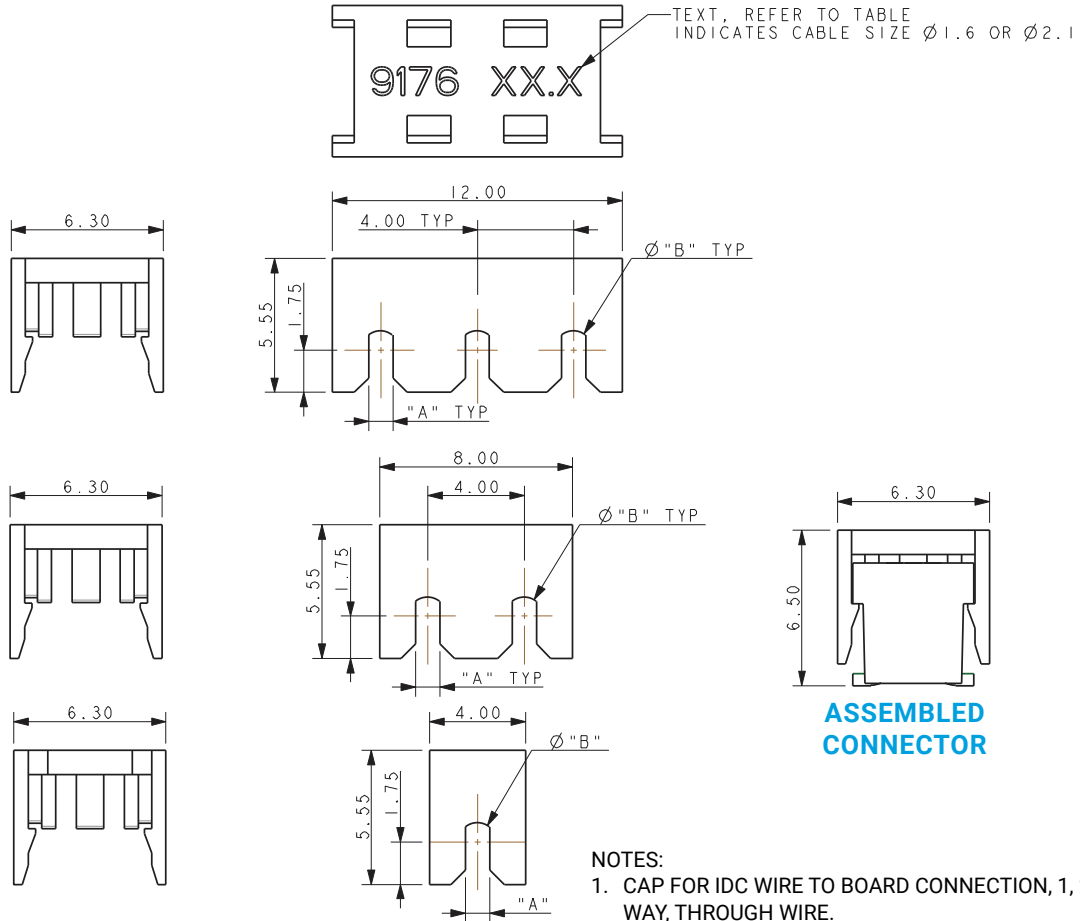

60-9176-001-016-X00 60-9176-002-016-X00 60-9176-003-016-X00

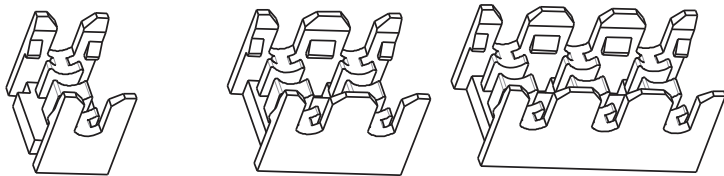

60-9176-001-021-X00 60-9176-002-021-X00 60-9176-003-021-X00

NOTES:

- CAP FOR IDC WIRE TO BOARD CONNECTION, 1, 2 AND 3 WAY, THROUGH WIRE.
- FOR USE WITH STANDARD 9176 IDC CONNECTORS, SEE PAGE 17 FOR THE CORRECT PART CODE TO MATCH WIRE.
- CAP MATERIAL: GLASS FILLED NYLON 46, FOR COLORS SEE TABLE BELOW.
- DIMENSIONS A, B AND TEXT, SEE TABLE BELOW.
- CAPS DESIGNED TO ACCOMMODATE WIRE INSULATION DIAMETERS 1.1MM TO 1.6MM AND 1.6MM TO 2.1MM.
- ALL DIMENSIONS SHOWN ARE REFERENCE DIMENSIONS.
- PACKED IN BAGS, 1000 PIECES PER BAG.
- ONE WAY CAP ASSEMBLY AID, REFER TO PAGE 25.
- ALL DIMENSIONS ± 0.20 TOLERANCE SPECIFIED.

Code	Slot A	Diameter B	Text	Color	X00
016	1.00	1.60	$\varnothing 1.6$	Black	000
021	1.50	2.10	$\varnothing 2.1$	White	100

STANDARD IDC 18-24 AWG: 00-9176

Accessory Cap - Wire Stop

60-9176-00X-0XX-X99 ACCESSORY CAP - WIRE STOP

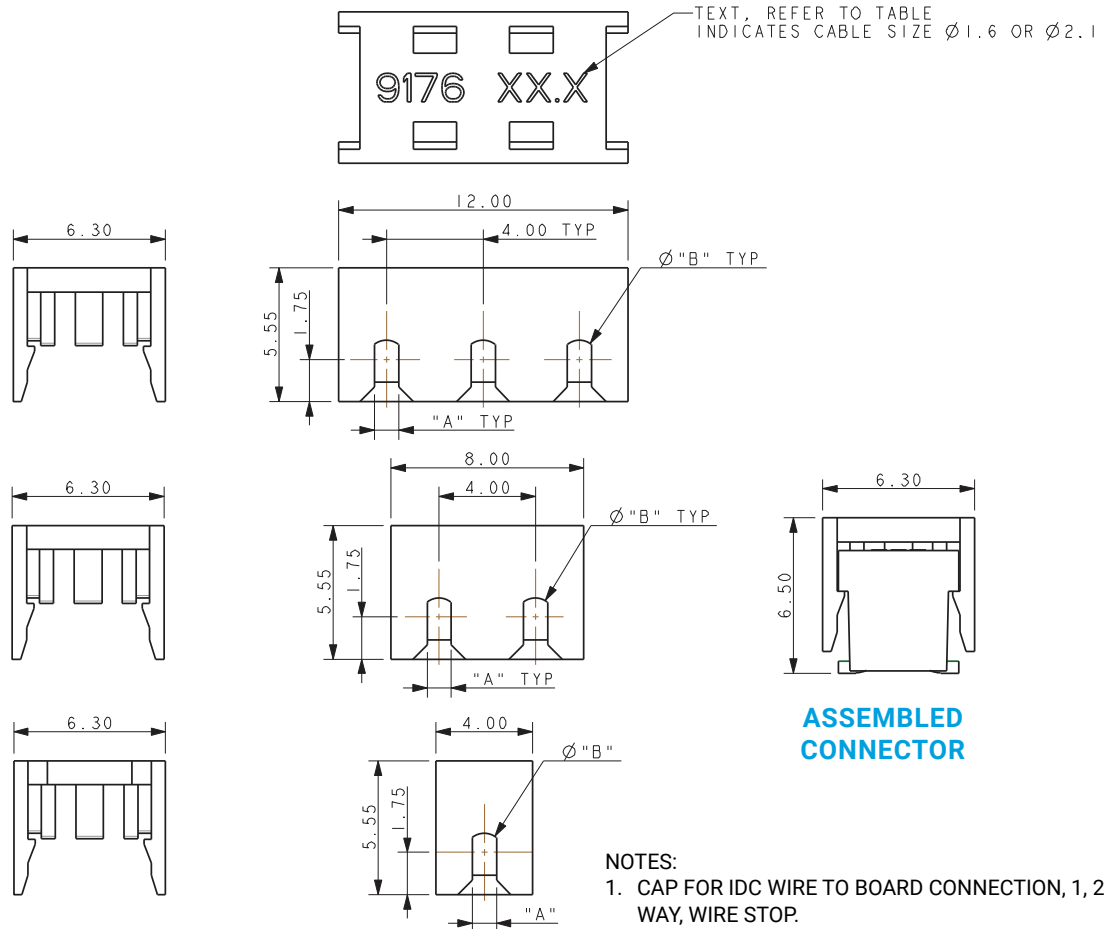

NOTES:

1. CAP FOR IDC WIRE TO BOARD CONNECTION, 1, 2 AND 3 WAY, WIRE STOP.
2. FOR USE WITH STANDARD 9176 IDC CONNECTORS, SEE PAGE 17 FOR THE CORRECT PART CODE TO MATCH WIRE.
3. CAP MATERIAL: GLASS FILLED NYLON 46, FOR COLORS SEE TABLE BELOW.
4. DIMENSIONS A, B AND TEXT, SEE TABLE BELOW.
5. CAPS DESIGNED TO ACCOMMODATE WIRE INSULATION DIAMETERS 1.1MM TO 1.6MM AND 1.6MM TO 2.1MM.
6. ALL DIMENSIONS SHOWN ARE REFERENCE DIMENSIONS.
7. PACKED IN BAGS, 1000 PIECES PER BAG.
8. ONE WAY CAP ASSEMBLY AID, REFER TO PAGE 25.
9. ALL DIMENSIONS ± 0.20 TOLERANCE SPECIFIED.

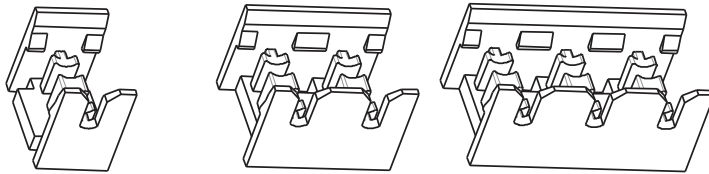

60-9176-001-016-X99 60-9176-002-016-X99 60-9176-003-016-X99

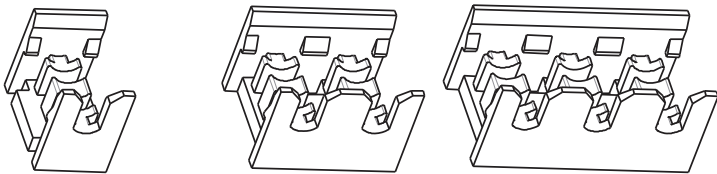

60-9176-001-021-X99 60-9176-002-021-X99 60-9176-003-021-X99

Code	Slot A	Diameter B	Text
016	1.00	1.60	Ø1.6
021	1.50	2.10	Ø2.1

Color	X00
Black	000
White	100

STANDARD IDC 18-24 AWG: 00-9176

Hand Insertion Tooling for Single 18/24 Gauge Wire

HAND INSERTION TOOLING FOR SINGLE 18/24 GAUGE WIRE

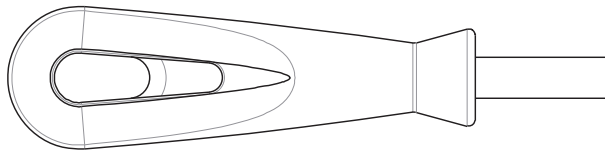

UNIVERSAL HANDLE

Details	Tool Part Number
6.35 A/F HEX BIT HOLDER	06 7000 7730 01 000

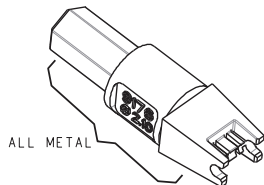

HIGH PRODUCTION Metal

Max Insulation Dia	Tool Part Number
Ø2.10	06 9176 7017 01 000
Ø1.60	06 9176 7017 02 000

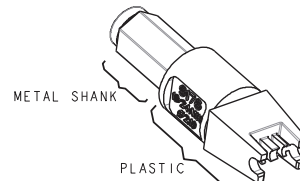

MEDIUM PRODUCTION Metal/Plastic

Max Insulation Dia	Tool Part Number
Ø2.10	06 9176 7016 01 000
Ø1.60	06 9176 7016 02 000

CLEARANCE AREA ON PCB FOR HAND TOOLING

1 WAY

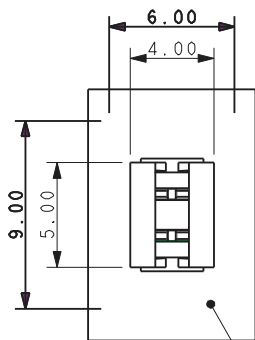

AREA TO BE KEPT CLEAR FOR TOOLING

2 WAY

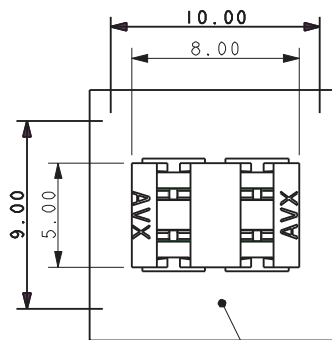

AREA TO BE KEPT CLEAR FOR TOOLING

3 WAY

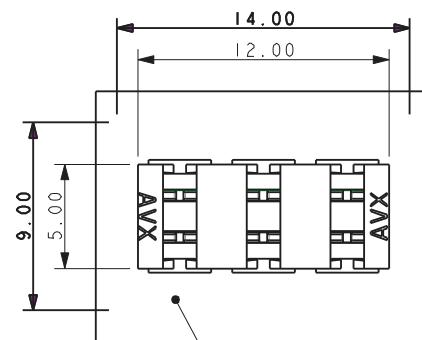

AREA TO BE KEPT CLEAR FOR TOOLING

STANDARD IDC 18-24 AWG: 00-9176

Insertion Tooling Requires Hand Press with Flat Rock Plates

INSERTION TOOLING REQUIRES HAND PRESS WITH FLAT ROCK PLATES

2 WAY

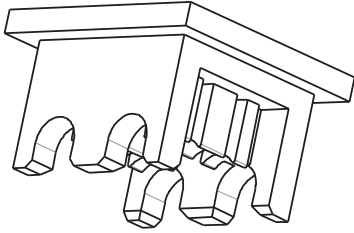

3 WAY

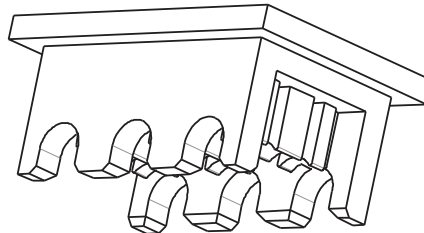

HIGH PRODUCTION Metal

No. of Ways	Max Insulation Dia	Tool Part Number
2	Ø2.10	06 9176 7017 01 002
	Ø1.60	06 9176 7017 02 002
3	Ø2.10	06 9176 7017 01 003
	Ø1.60	06 9176 7017 02 003

PCB RESTRICTED AREAS FOR PRESS ASSEMBLY TOOLING

2 WAY

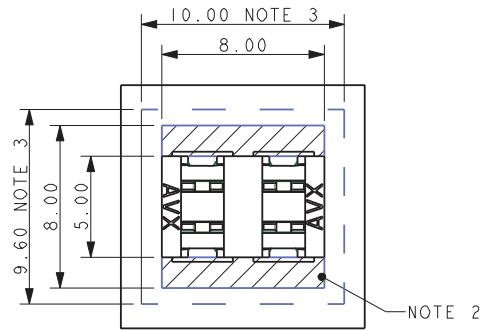
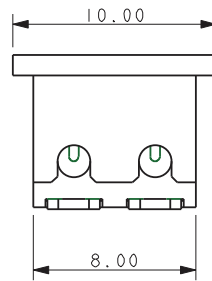
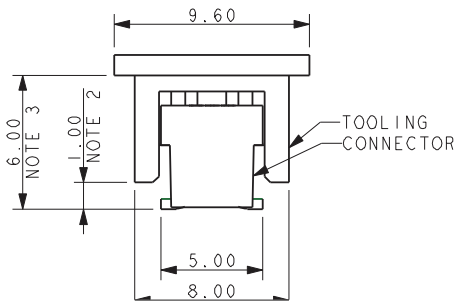

3 WAY

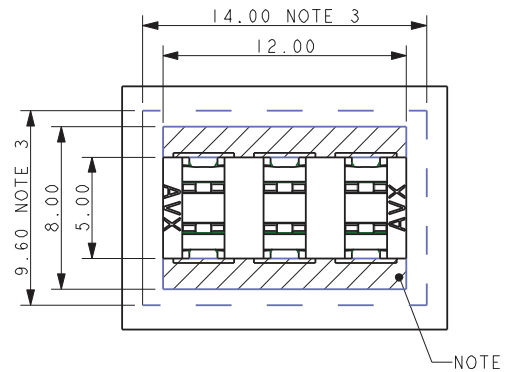
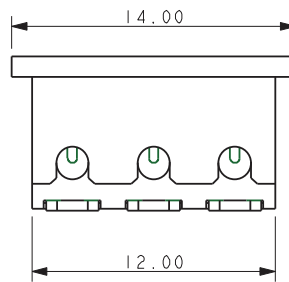
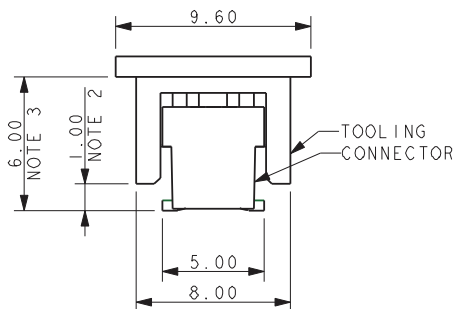

NOTES:

1. DIMENSIONS SHOWN ARE REFERENCE DIMENSIONS.
2. MAXIMUM COMPONENT HEIGHT 1.00MM IN THIS AREA.
3. MAXIMUM COMPONENT HEIGHT 6.00MM IN THIS AREA.
4. THE SAME RESTRICTIONS APPLY TO ALL WIRE INSULATION DIAMETERS.
5. 2 AND 3 WAY TOOLS ONLY, FOR USE UNDER HAND PRESS WITH FLAT PLATES.
6. FOR HAND TOOLING REFER TO PAGE 23.
7. ALL DIMENSIONS ± 0.20 UNLESS TOLERANCE SPECIFIED.

STANDARD IDC 18-24 AWG: 00-9176

Hand Insertion Tooling for One Way Cap Insertion / Clearance Area on PCB for Hand Tooling

HAND INSERTION TOOLING FOR ONE WAY CAP INSERTION

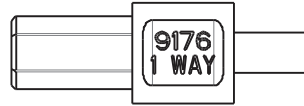
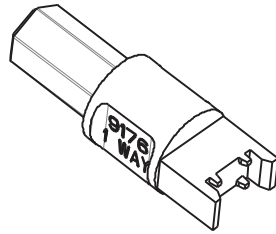

06-9176-7028-01-000

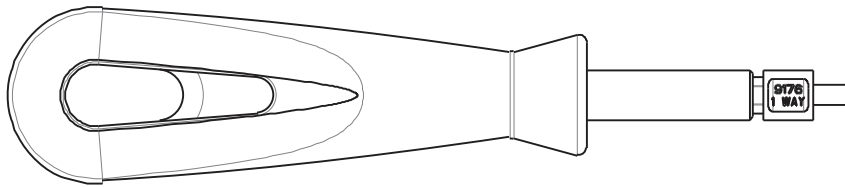

TO BE USED WITH 06-7000-7730-01-000
UNIVERSAL HANDLE

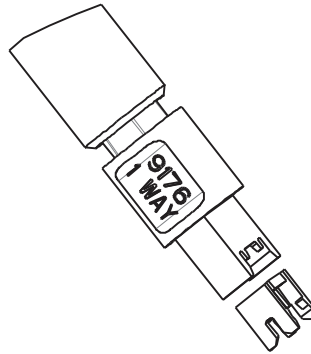

FOR ASSEMBLY INSTRUCTION REFER TO 201-01-124 APPLICATION NOTES

CLEARANCE AREA ON PCB FOR HAND TOOLING

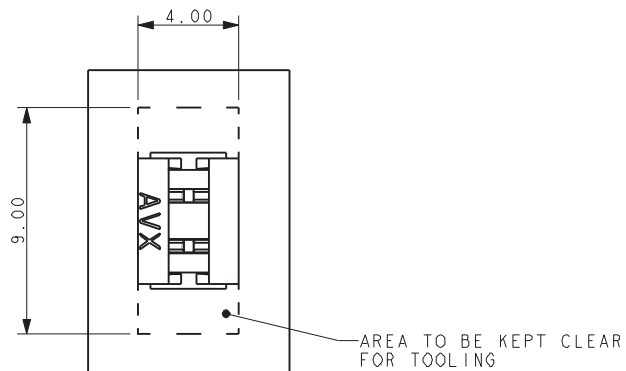

STANDARD IDC 18-24 AWG: 00-9176

Assembled Connector

ASSEMBLED CONNECTOR

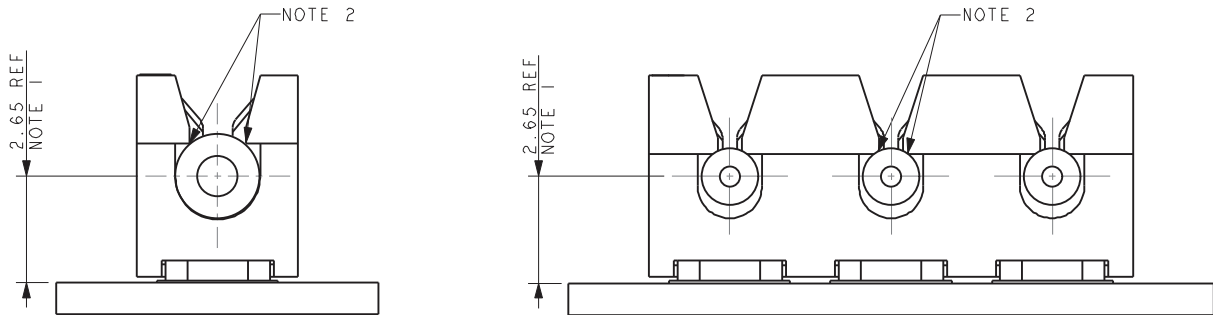

ASSEMBLED CONNECTOR

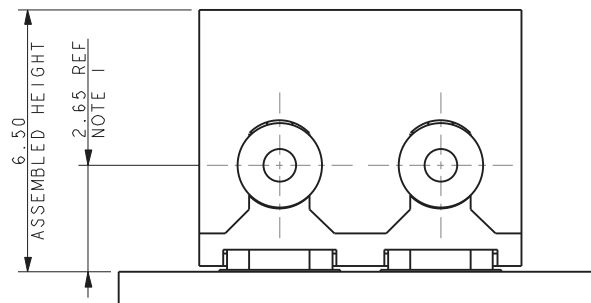

CONNECTOR WITH CAP

NOTES:

1. ASSEMBLED HEIGHTS INCLUDE 0.10MM ALLOWANCE FOR PAD AND SOLDER THICKNESS.
NO ALLOWANCE HAS BEEN MADE FOR ANY SOLDER RESIST OR OTHER FEATURES.
2. WHEN THE WIRE IS ASSEMBLED THE INSULATION SHOULD BE TRAPPED BY THESE EDGES.

CAPPED 18-24 AWG: 9176-700

General Information



The market and applications for simple and reliable discrete Wire-to-Board connectors continue to evolve. KYOCERA AVX first introduced the 9176 series of surface mountable Insulation Displacement Connectors (IDC) in 2007. Developed for harsh industrial and automotive applications, these connectors have been used in hundreds of applications from today's "Smart Meter" all the way down to a simple sensor termination to a PCB. Size and performance has been one of the key factors for selecting this connector in terminating 18-24AWG wires to a PCB.

The next generation of IDC connector moves beyond all of the technical and performance attributes to address the "User Friendliness" of the product. By changing the insulator from acting as a connector body and make it more like a contact carrier, the insulator becomes the wire location and insertion aid without any special tools. The wire is just inserted into the cap (no stripping required) and then pressed down to provide a secure "Gas Tight" termination. This configuration simplifies and cost reduces the entire wire termination process for connecting discrete wires to a PCB.

APPLICATIONS

- Connecting discrete wire components to a PCB
- Bringing power and signals onto a PCB
- Daisy chaining PCB's together to create a continuous string
- Reference Product Specification 201-01-140

FEATURES AND BENEFITS

- IDC contact provides a gas-tight connection to the PCB for long term reliability
- Plastic cap retains the contacts in position prior to automatic placement, then acts as the assembly tool to terminate the wires; no special tooling.
- Tested to automotive levels on shock, vibration and temperature cycling for reliability
- Identical contact and footprint pattern to the existing 9176 for full backward compatibility and functionality
- The IDC contact reduces the total applied cost versus solder or crimp processes
- Connectors are available in two configurations for maximum flexibility; End and Through Wire

ELECTRICAL

- Current Rating: 10 Amps / Contact
- Voltage Rating: 300 VAC

ENVIRONMENTAL

- Operating Temperature: -40°C to +125°C

MECHANICAL

- Insulator Material: Nylon UL94VO
- Contact Material: Phosphor Bronze
- Plating: Tin over Nickel

HOW TO ORDER

00 **9176** **00X**

Prefix Series Number of Ways

001 = 1
002 = 2
003 = 3

7XX

Wire Gauge Size
Capped - IDC Connector

Code	Accepted Wire Gauge	Wire Insulation
701	18 AWG Stranded	Ø 1.6 - 2.1
711	20 AWG Solid and Stranded	Ø 1.6 - 2.1
722	22 AWG Solid and Stranded	Ø 1.1 - 1.6
732	24 AWG Solid and Stranded	Ø 1.1 - 1.6

X

Insulator Color
All Sizes

9 = UL White (Standard)
8 = UL Black (Special Order)

One Way Only (Special Order)

2 = UL Brown
3 = UL Blue
4 = UL Yellow
5 = UL Red
6 = UL Green
7 = UL Orange

X

Cap Options

Code	Cap Option	Description	Detail
0	Through Wire	Allows wire to be terminated at any point	Pages 26 - 28
9	Wire Stop	Terminates end of wire End Protected by stop face	Pages 29 - 31

6

Plating Option

6 = Pure Tin all over

Certification: UL File #E90723



CAPPED 18-24 AWG: 9176-700

1 Position - Through Wire

18 - 24 AWG 1 WAY IDC CONNECTOR THROUGH WIRE CAPPED IDC

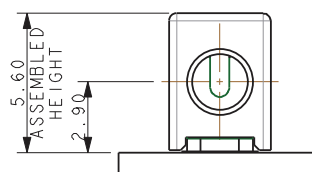
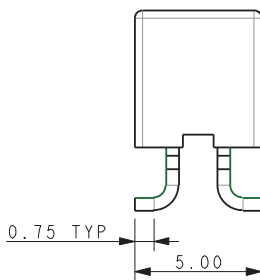
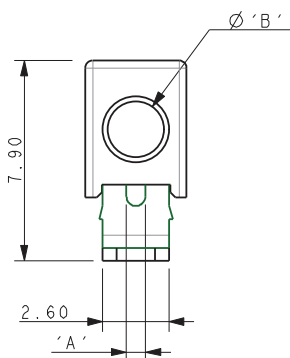
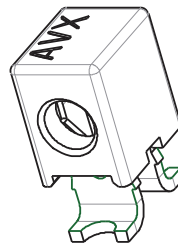
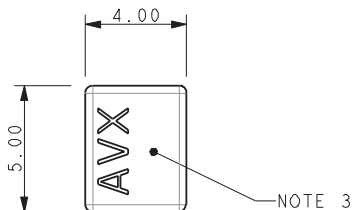

MOUNTED ON PCB

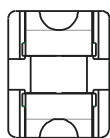

NOTES:

- 1 WAY CONNECTOR FOR IDC WIRE TO BOARD CONNECTION. PRE-ASSEMBLED THROUGH WIRE CAP, CODE REFER TO PAGE 27.
- CONTACT/CAP TO MATCH 20AWG-24AWG SOLID AND STRANDED WIRES, 18AWG WILL ONLY ACCEPT STRANDED WIRES, SEE TABLE.
- FLAT FACE ON TOP OF CAP TO AID PICK AND PLACE ASSEMBLY.
- FOR FULL PRODUCT SPECIFICATION ON STANDARD CONNECTORS REFER TO ELCO SPEC 201-01-138, UL COMPONENTS REFER TO ELCO SPEC 201-01-138UL.
- ASSEMBLY PROCEDURE, REFER TO APPLICATION NOTES 201-01-140.
- GENERAL TOLERANCE ± 0.20 UNLESS STATED.
- PACKED IN TAPE AND REEL, QUANTITY PER REEL 600.
- CONNECTOR OUTLINE.
- CONTACT MATERIAL: TIN PLATED COPPER ALLOY.
- INSULATION MATERIAL: HIGH TEMPERATURE NYLON, GLASS FILLED. UL94 V-0, COLOR REFER TO PAGE 27.
- GENERAL TOLERANCE ± 0.20 UNLESS STATED.
- FOR UL PRODUCT CODES UL REFERENCE E90723 (US AND CANADA).

Code	Accepted Wire Gauge	A	Wire Insulation	B
701	18 AWG Stranded	0.74	Ø1.621	2.1
711	20 AWG Solid and Stranded	0.60	Ø1.621	2.1
722	22 AWG Solid and Stranded	0.47	Ø 1.1-1.6	1.6
732	24 AWG Solid and Stranded	0.37	Ø 1.1-1.6	1.6

PACKING DETAILS

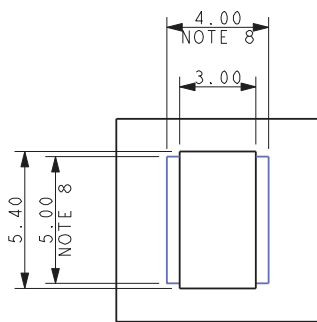

SUGGEST PCB LAYOUT

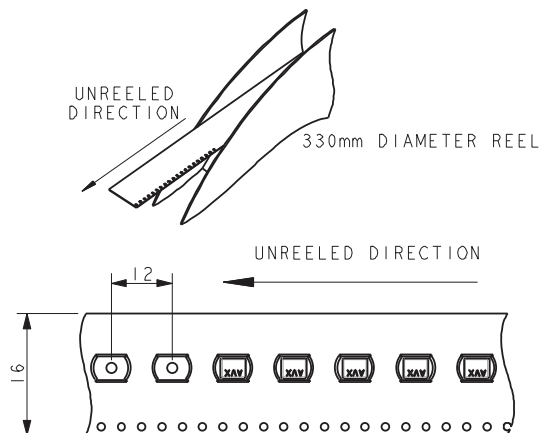

QUANTITY PER REEL 600

CAPPED 18-24 AWG: 9176-700

2 Position - Through Wire

18 - 24 AWG 2 WAY IDC CONNECTOR THROUGH WIRE CAPPED IDC

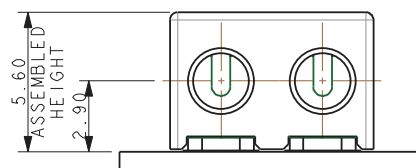
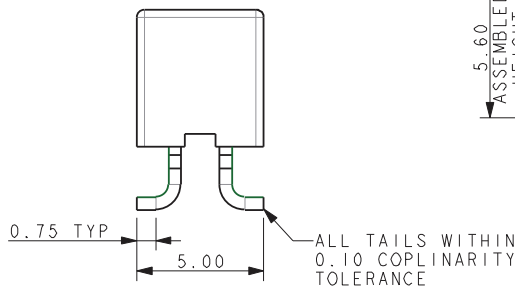
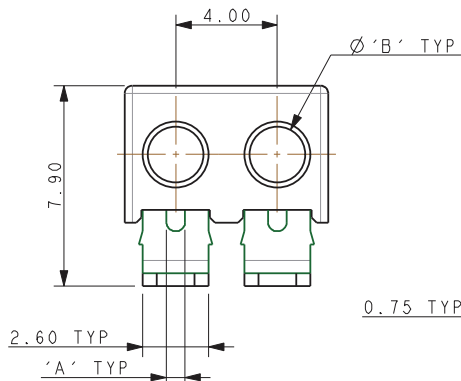
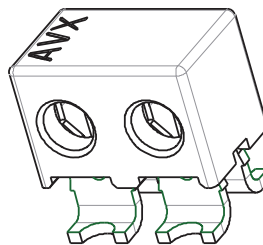
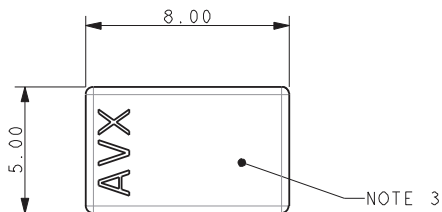

MOUNTED ON PCB

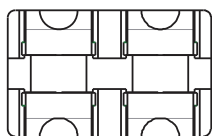

Code	Accepted Wire Gauge	A	Wire Insulation	B
701	18 AWG Stranded	0.74	Ø1.621	2.1
711	20 AWG Solid and Stranded	0.60	Ø1.621	2.1
722	22 AWG Solid and Stranded	0.47	Ø 1.1-1.6	1.6
732	24 AWG Solid and Stranded	0.37	Ø 1.1-1.6	1.6

NOTES:

- 2 WAY CONNECTOR FOR IDC WIRE TO BOARD CONNECTION. PRE-ASSEMBLED THROUGH WIRE CAP, CODE REFER TO PAGE 27.
- CONTACT/CAP TO MATCH 20AWG-24AWG SOLID AND STRANDED WIRES, 18AWG WILL ONLY ACCEPT STRANDED WIRES, SEE TABLE.
- FLAT FACE ON TOP OF CAP TO AID PICK AND PLACE ASSEMBLY.
- FOR FULL PRODUCT SPECIFICATION ON STANDARD CONNECTORS REFER TO ELCO SPEC 201-01-138, UL COMPONENTS REFER TO ELCO SPEC 201-01-138UL.
- ASSEMBLY PROCEDURE, REFER TO APPLICATION NOTES 201-01-140.
- GENERAL TOLERANCE ± 0.20 UNLESS STATED.
- PACKED IN TAPE AND REEL, QUANTITY PER REEL 600.
- CONNECTOR OUTLINE.
- CONTACT MATERIAL: TIN PLATED COPPER ALLOY.
- INSULATION MATERIAL: HIGH TEMPERATURE NYLON, GLASS FILLED. UL94 V-0, COLOR REFER TO PAGE 27.
- GENERAL TOLERANCE ± 0.20 UNLESS STATED.
- FOR UL PRODUCT CODES UL REFERENCE E90723 (US AND CANADA).

PACKING DETAILS

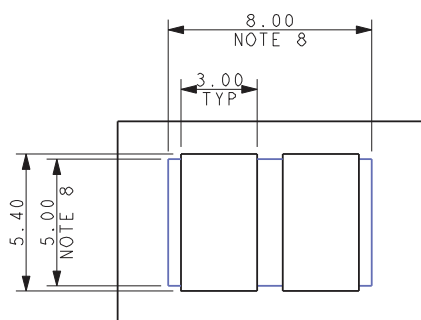

SUGGEST PCB LAYOUT

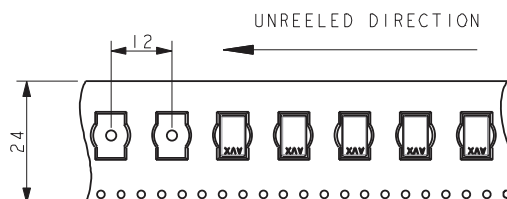
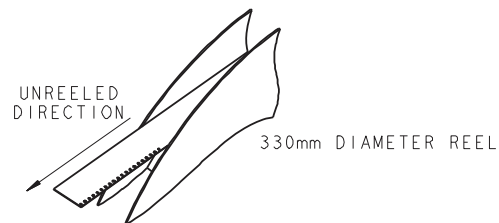

QUANTITY PER REEL 600

CAPPED 18-24 AWG: 9176-700

3 Position - Through Wire

18 - 24 AWG 3 WAY IDC CONNECTOR THROUGH WIRE CAPPED IDC

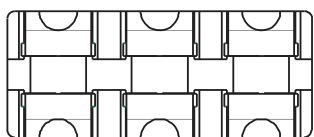
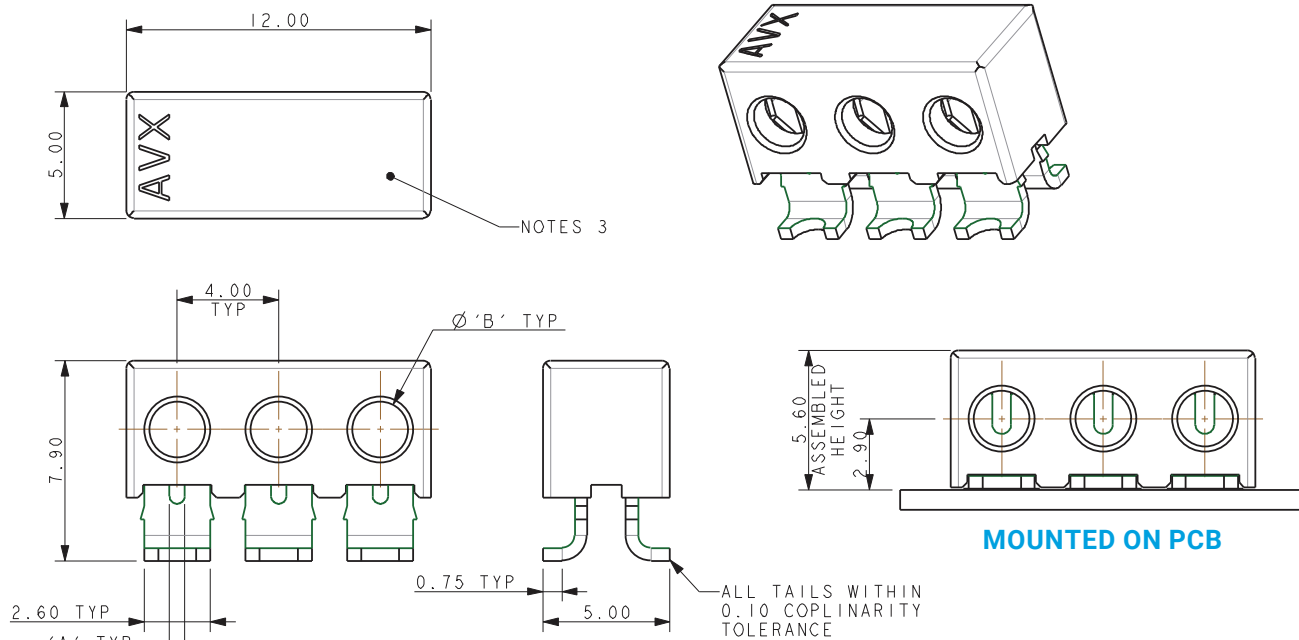

Code	Accepted Wire Gauge	A	Wire Insulation	B
701	18 AWG Stranded	0.74	Ø1.6-2.1	2.1
711	20 AWG Solid and Stranded	0.60	Ø1.6-2.1	2.1
722	22 AWG Solid and Stranded	0.47	Ø 1.1-1.6	1.6
732	24 AWG Solid and Stranded	0.37	Ø 1.1-1.6	1.6

NOTES:

- 3 WAY CONNECTOR FOR IDC WIRE TO BOARD CONNECTION. PRE-ASSEMBLED THROUGH WIRE CAP, CODE REFER TO PAGE 27.
- CONTACT/CAP TO MATCH 20AWG-24AWG SOLID AND STRANDED WIRES, 18AWG WILL ONLY ACCEPT STRANDED WIRES, SEE TABLE.
- FLAT FACE ON TOP OF CAP TO AID PICK AND PLACE ASSEMBLY.
- FOR FULL PRODUCT SPECIFICATION ON STANDARD CONNECTORS REFER TO ELCO SPEC 201-01-138, UL COMPONENTS REFER TO ELCO SPEC 201-01-138UL.
- ASSEMBLY PROCEDURE, REFER TO APPLICATION NOTES 201-01-140.
- GENERAL TOLERANCE ± 0.20 UNLESS STATED.
- PACKED IN TAPE AND REEL, QUANTITY PER REEL 600.
- CONNECTOR OUTLINE.
- CONTACT MATERIAL: TIN PLATED COPPER ALLOY.
- INSULATION MATERIAL: HIGH TEMPERATURE NYLON, GLASS FILLED. UL94 V-0, COLOR REFER TO PAGE 27.
- GENERAL TOLERANCE ± 0.20 UNLESS STATED.
- FOR UL PRODUCT CODES UL REFERENCE E90723 (US AND CANADA).

PACKING DETAILS

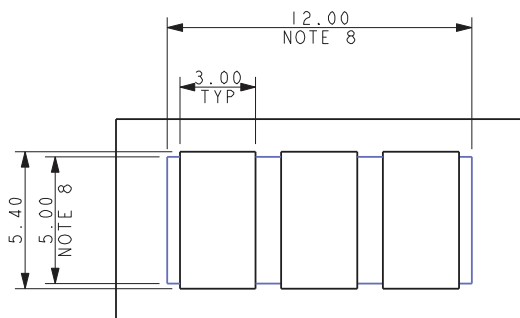

SUGGEST PCB LAYOUT

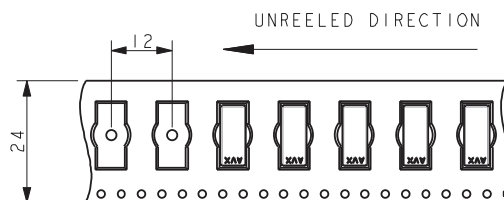
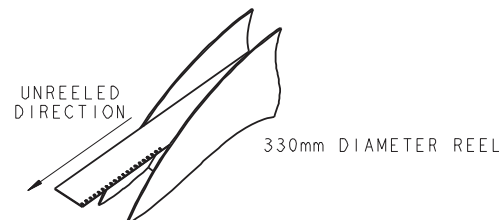

QUANTITY PER REEL 600

CAPPED 18-24 AWG: 9176-700

1 Position - Wire Stop

18 - 24 AWG 1 WAY IDC CONNECTOR WIRE STOP CAPPED IDC

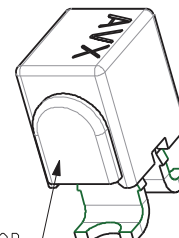
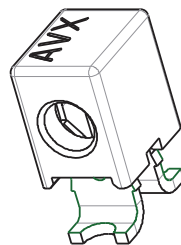
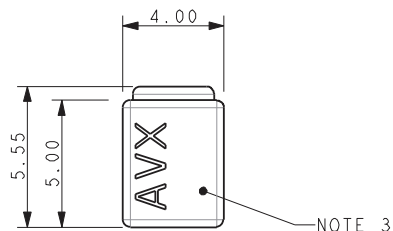

WIRE STOP
NOTE 11

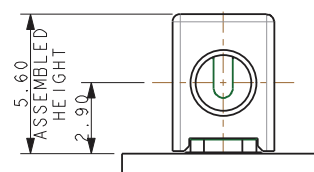
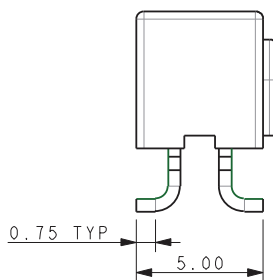
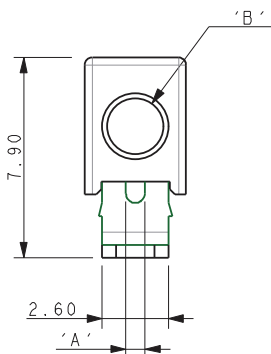

MOUNTED ON PCB

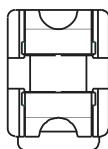

NOTES:

- 1 WAY CONNECTOR FOR IDC WIRE TO BOARD CONNECTION. PRE-ASSEMBLED WIRE STOP CAP, CODE REFER TO PAGE 27.
- CONTACT/CAP TO MATCH 20AWG-24AWG SOLID AND STRANDED WIRES, 18AWG WILL ONLY ACCEPT STRANDED WIRES, SEE TABLE.
- FLAT FACE ON TOP OF CAP TO AID PICK AND PLACE ASSEMBLY.
- FOR FULL PRODUCT SPECIFICATION ON STANDARD CONNECTORS REFER TO ELCO SPEC 201-01-138, UL COMPONENTS REFER TO ELCO SPEC 201-01-138UL.
- ASSEMBLY PROCEDURE, REFER TO APPLICATION NOTES 201-01-140.
- GENERAL TOLERANCE ± 0.20 UNLESS STATED.
- PACKED IN TAPE AND REEL, QUANTITY PER REEL 600.
- CONNECTOR OUTLINE.
- CONTACT MATERIAL: TIN PLATED COPPER ALLOY.
- INSULATION MATERIAL: HIGH TEMPERATURE NYLON, GLASS FILLED. UL94 V-0, COLOR REFER TO PAGE 27.
- GENERAL TOLERANCE ± 0.20 UNLESS STATED.
- FOR UL PRODUCT CODES UL REFERENCE E90723 (US AND CANADA).

Code	Accepted Wire Gauge	A	Wire Insulation	B
701	18 AWG Stranded	0.74	$\varnothing 1.6-2.1$	2.1
711	20 AWG Solid and Stranded	0.60	$\varnothing 1.6-2.1$	2.1
722	22 AWG Solid and Stranded	0.47	$\varnothing 1.1-1.6$	1.6
732	24 AWG Solid and Stranded	0.37	$\varnothing 1.1-1.6$	1.6

PACKING DETAILS

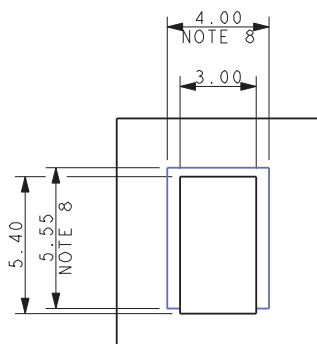

SUGGEST PCB LAYOUT

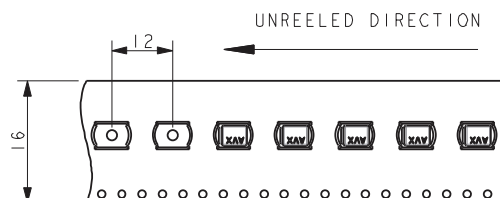
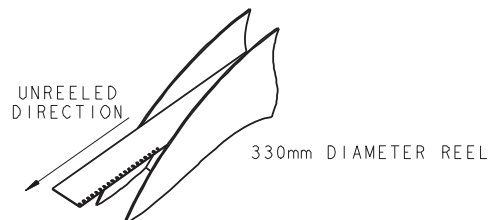

CAPPED 18-24 AWG: 9176-700

2 Position - Wire Stop

18 - 24 AWG 2 WAY IDC CONNECTOR WIRE STOP CAPPED IDC

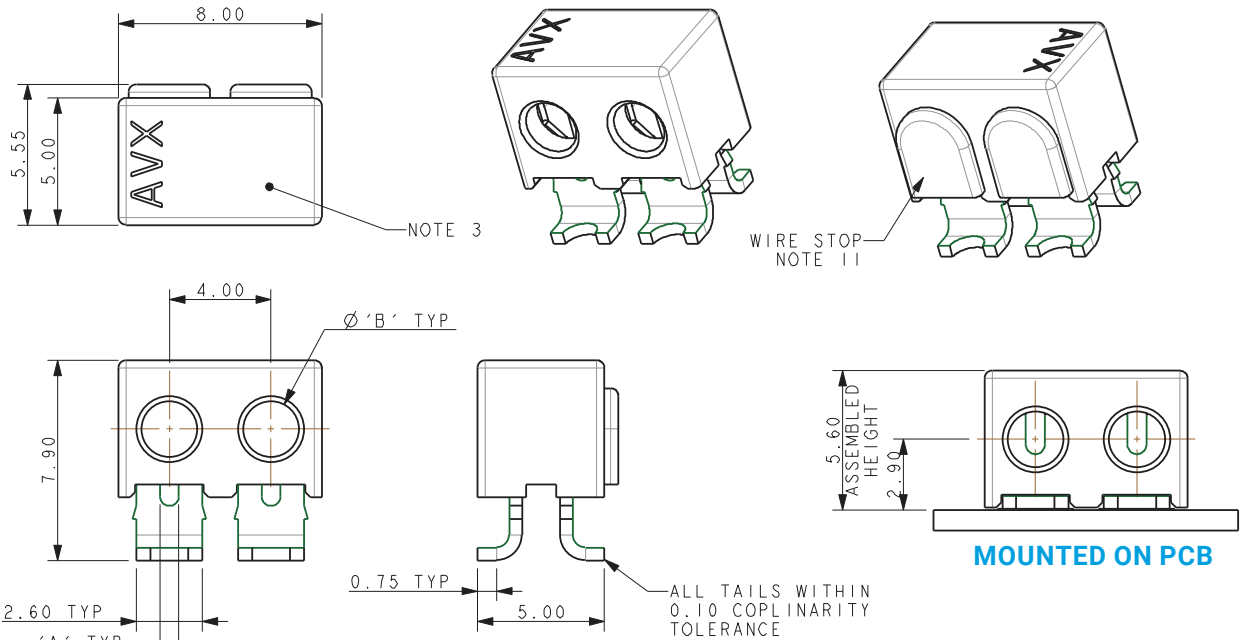

NOTES:

1. 2 WAY CONNECTOR FOR IDC WIRE TO BOARD CONNECTION. PRE-ASSEMBLED WIRE STOP CAP, CODE REFER TO PAGE 27.
2. CONTACT/CAP TO MATCH 20AWG-24AWG SOLID AND STRANDED WIRES, 18AWG WILL ONLY ACCEPT STRANDED WIRES, SEE TABLE.
3. FLAT FACE ON TOP OF CAP TO AID PICK AND PLACE ASSEMBLY.
4. FOR FULL PRODUCT SPECIFICATION ON STANDARD CONNECTORS REFER TO ELCO SPEC 201-01-138, UL COMPONENTS REFER TO ELCO SPEC 201-01-138UL.
5. ASSEMBLY PROCEDURE, REFER TO APPLICATION NOTES 201-01-140.
6. GENERAL TOLERANCE ± 0.20 UNLESS STATED.
7. PACKED IN TAPE AND REEL, QUANTITY PER REEL 600.
8. CONNECTOR OUTLINE.
9. CONTACT MATERIAL: TIN PLATED COPPER ALLOY.
10. INSULATION MATERIAL: HIGH TEMPERATURE NYLON, GLASS FILLED. UL94 V-0, COLOR REFER TO PAGE 27.
11. GENERAL TOLERANCE ± 0.20 UNLESS STATED.
12. FOR UL PRODUCT CODES UL REFERENCE E90723 (US AND CANADA).

Code	Accepted Wire Gauge	A	Wire Insulation	B
701	18 AWG Stranded	0.74	$\emptyset 1.6-2.1$	2.1
711	20 AWG Solid and Stranded	0.60	$\emptyset 1.6-2.1$	2.1
722	22 AWG Solid and Stranded	0.47	$\emptyset 1.1-1.6$	1.6
732	24 AWG Solid and Stranded	0.37	$\emptyset 1.1-1.6$	1.6

PACKING DETAILS

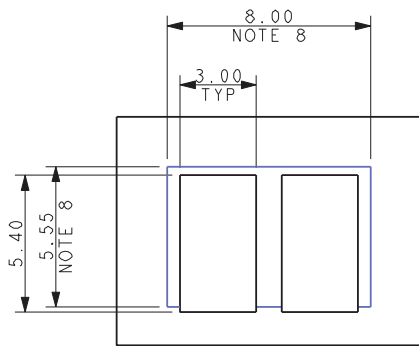

SUGGEST PCB LAYOUT

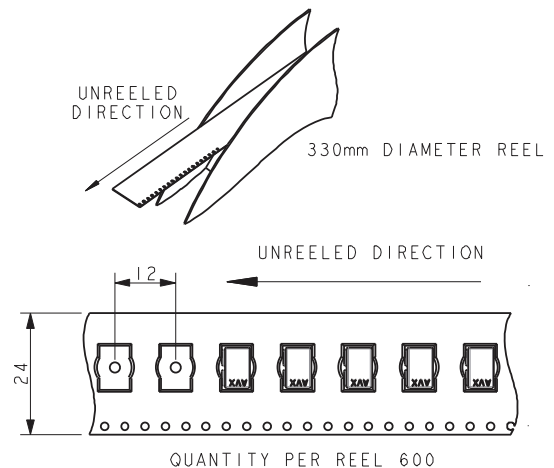

CAPPED 18-24 AWG: 9176-700

3 Position - Wire Stop

18 - 24 AWG 3 WAY IDC CONNECTOR WIRE STOP CAPPED IDC

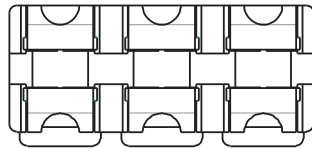
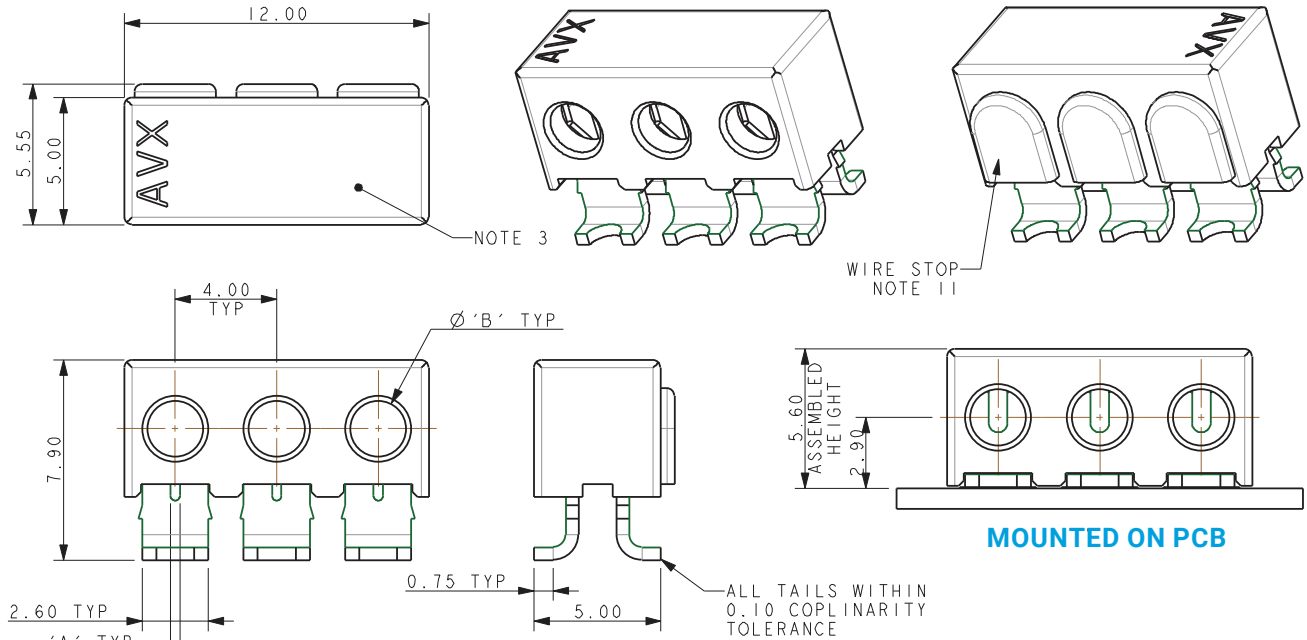

Code	Accepted Wire Gauge	A	Wire Insulation	B
701	18 AWG Stranded	0.74	Ø1.6-2.1	2.1
711	20 AWG Solid and Stranded	0.60	Ø1.6-2.1	2.1
722	22 AWG Solid and Stranded	0.47	Ø 1.1-1.6	1.6
732	24 AWG Solid and Stranded	0.37	Ø 1.1-1.6	1.6

NOTES:

- 3 WAY CONNECTOR FOR IDC WIRE TO BOARD CONNECTION. PRE-ASSEMBLED WIRE STOP CAP, CODE REFER TO PAGE 27.
- CONTACT/CAP TO MATCH 20AWG-24AWG SOLID AND STRANDED WIRES, 18AWG WILL ONLY ACCEPT STRANDED WIRES, SEE TABLE.
- FLAT FACE ON TOP OF CAP TO AID PICK AND PLACE ASSEMBLY.
- FOR FULL PRODUCT SPECIFICATION ON STANDARD CONNECTORS REFER TO ELCO SPEC 201-01-138, UL COMPONENTS REFER TO ELCO SPEC 201-01-138UL.
- ASSEMBLY PROCEDURE, REFER TO APPLICATION NOTES 201-01-140.
- GENERAL TOLERANCE ± 0.20 UNLESS STATED.
- PACKED IN TAPE AND REEL, QUANTITY PER REEL 600.
- CONNECTOR OUTLINE.
- CONTACT MATERIAL: TIN PLATED COPPER ALLOY.
- INSULATION MATERIAL: HIGH TEMPERATURE NYLON, GLASS FILLED. UL94 V-0, COLOR REFER TO PAGE 27.
- GENERAL TOLERANCE ± 0.20 UNLESS STATED.
- FOR UL PRODUCT CODES UL REFERENCE E90723 (US AND CANADA).

PACKING DETAILS

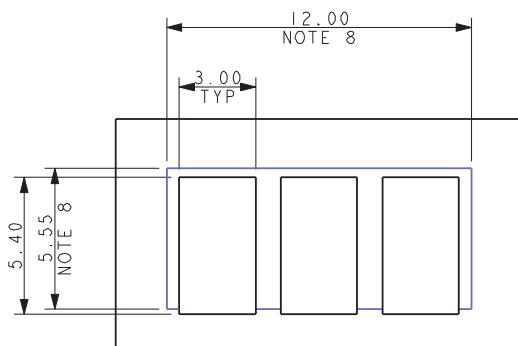

SUGGEST PCB LAYOUT

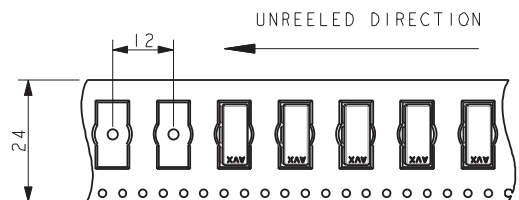
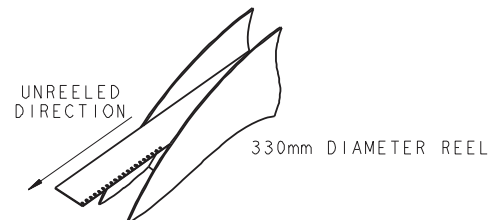

QUANTITY PER REEL 600

CAPPED 18-24 AWG: 9176-700

Assembly - Through Wire and Wire Stop

18-24 AWG ASSEMBLED CAPPED IDC CONNECTORS

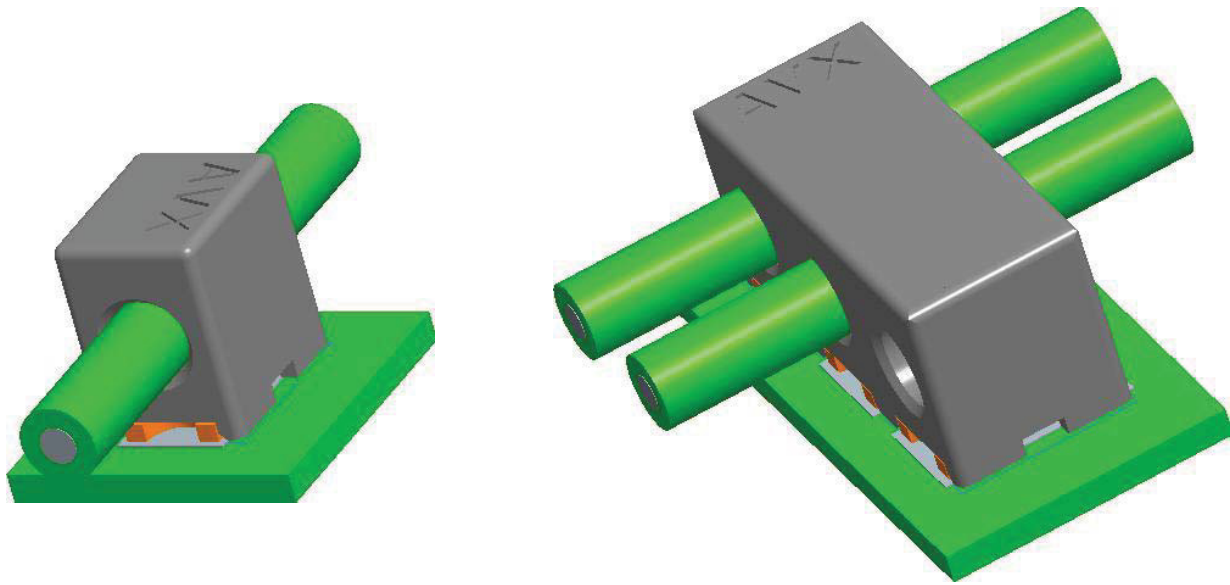

TYPICAL THROUGH WIRE ASSEMBLY

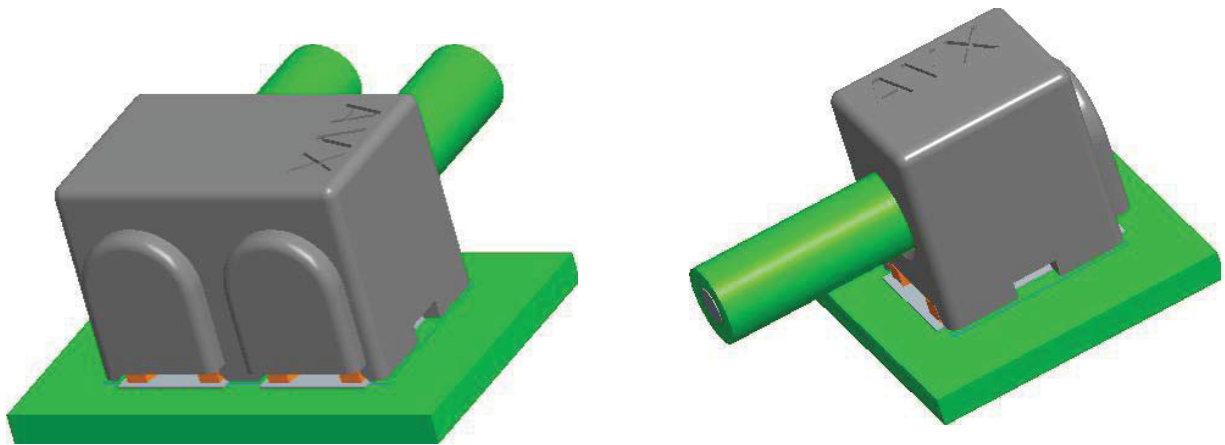

TYPICAL WIRE STOP ASSEMBLY

SINGLE IDC CONTACT 22-28 AWG: 9176-400

General Information



The 917X series of surface mount Insulation Displacement Connectors (IDC) were developed to meet the harsh automotive and industrial market applications for connecting individual wires directly to a PCB ranging from 14 AWG to 28 AWG. This industry proven contact system has been tested to automotive levels of shock, vibration, and temperature cycling to prove their reliability and robustness. This new single contact was developed as a standalone component to enhance the application uses with the IDC technology. The simplicity of inserting a wire into an SMT contact with a small tool or optional retention / termination cap allows a wide range of devices to be connected to the PCB without soldering. In SSL applications specifically, these contacts are used to bring power and signal onto the PCB or are used to daisy chain multiple boards together in a long string. While the IDC contact provides a gas-tight connection to conductor of the wire, the optional cap provides a positive strain relief even in the harshest conditions. In case of repair, the wires can be removed and replace up to three times.

The single 9176-400 series contact and cap accepts 22 AWG to 28 AWG wires with an insulation diameter ranging from 1.0mm to 1.5mm. These dual beam contacts support a 6 amp current rating with a large SMT solder base to provide maximum stability on the PCB. The optional locking strain relief cap acts as the termination tool for severe vibration applications.

APPLICATIONS

- Connecting discrete wire components directly to the PCB
- Bringing power and signals onto a PCB
- Daisy chaining PCB's together to create a continuous string of boards
- Application notes: refer to 201-01-124

FEATURES AND BENEFITS

- IDC contact is supplied in T&R pockets for standard SMT placement
- IDC contact provides a gas-tight connection to the PCB for long term reliability
- Optional termination cap provides additional strain relief for severe environments
- Tested to automotive levels on shock, vibration and temperature cycling for reliability
- Reduced total applied cost versus solder or crimp processes
- Individual contacts can be located anywhere on the PCB based on specific application

ELECTRICAL

- Current Rating: 6 Amps/Contact
- Voltage Rating: Dependant on component proximity

ENVIRONMENTAL

- Operating Temperature: -40°C to +125°C

MECHANICAL

- Insulator Material: Nylon 46: UL94V0
- Contact Material: Phosphor Bronze
- Plating: Tin over Nickel
- Durability: 3 Cycles

HOW TO ORDER – CONTACT OPTIONS

70
Prefix
70 = Contact

9176
Series

001
Number of Ways

Code	No of Ways	Details
001	1	Page 36

4XX
Wire Gauge Size

Code	Accepted Wire Gauge
422	22 Gauge Solid or Stranded
432	24 Gauge Solid or Stranded
442	26 Gauge Solid or Stranded
443	28 Gauge Solid or Stranded

006
Plating Option
006 = Pure Tin all over

HOW TO ORDER – CAP OPTIONS

60
Prefix
60 = Cap

9176
Series

001
Number of Ways

Code	No of Ways	Details
001	1	Page 40

415
Wire Gauge Size

Code	Wire Insulation
415	Ø 0.75-1.5

X00
Insulator Color

Code	Color	Application
000	Black	Industrial
100	White	Lighting



CONNECTOR/TOOLING PART NUMBER MATRIX

SERIES 9176-400 IDC				HAND INSERTION TOOLING*		ACCESSORY CAPS		
AWG	Wire Insulation	Positions	Part Number	Plastic (medium volume)	Metal (high volume)	Cap Application Tool	White	Black
22	Ø 1.0 - 1.5	1p	709176001422006	069176702201000	069176702101000	069176702301000	609176001415100	609176001415000
24	Ø 1.0 - 1.5	1p	709176001432006	069176702201000	069176702101000	069176702301000	609176001415100	609176001415000
26	Ø 0.7 - 1.0	1p	709176001442006	069176702201000	069176702101000	069176702301000	609176001415100	609176001415000
28	Ø 0.7 - 1.0	1p	709176001443006	069176702201000	069176702101000	069176702301000	609176001415100	609176001415000

* Hand Insertion Tooling and Cap Application - Universal Hand Tool 067000773001000; Consult Application Notes 201-01-124

Certification: UL File #E90723

SINGLE IDC CONTACT 22-28 AWG: 9176-400

Contact Details

CONTACT DETAILS

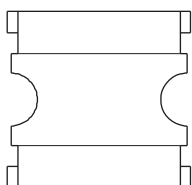
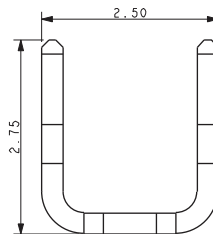
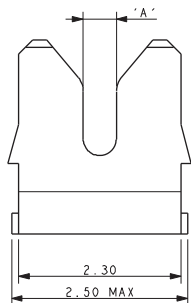

AREA AVAILABLE FOR PICK & PLACE

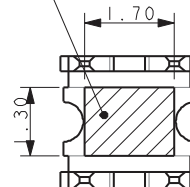

Code	Accepted Wire Gauge	A
422	22AWG Solid or Stranded	0.47
432	24AWG Solid or Stranded	0.37
442	26AWG Solid or Stranded	0.28
443	28AWG Solid or Stranded	0.20

NOTES:

- CONNECTOR FOR IDC WIRE TO BOARD CONNECTION.
- CONTACT MATERIAL: PHOSPHOR BRONZE.
- CONTACT PLATING: PURE TIN.
- CONNECTOR DESIGNED TO ACCEPT BETWEEN 22AWG AND 28AWG SOLID AND STRANDED WIRE, SEE TABLE.
- ALL DIMENSIONS ± 0.20 UNLESS TOLERANCED.
- FOR FULL PRODUCT SPECIFICATION REFER TO ELCO SPEC 201-01-126 AND APPLICATION NOTES 201-01-124.
- SMT PCB LAYOUT, REFER TO PAGE 37.
- PACKING IN TAPE AND REEL, QUANTITY 2000 PER REEL.
- WHEN REQUIRED, MATCHING CAP DETAILS ON DRAWING 60-9176-001-4XX-X06S.
- ASSEMBLY TOOLING ON PAGE 39 FOR WIRE INTO CONTACT AND PAGE 38 FOR CAP.
- UL REFERENCE E90723, THIS UL REFERENCE ALSO APPLIES WHEN COMBINED WITH KYOCERA AVX SPECIFIED OPTIONAL CAP.

PACKING DETAILS

REEL QTY	2 000
LEADER	480MM
TRAILER	120MM

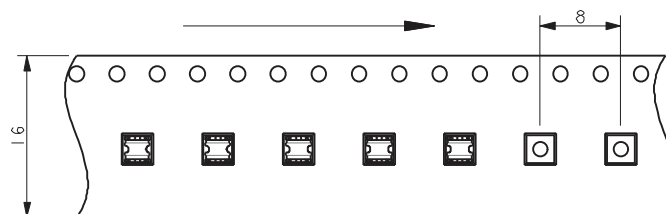
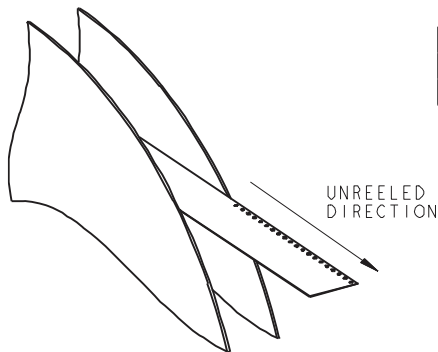

SINGLE IDC CONTACT 22-28 AWG: 9176-400

PCB Layout

22-28 AWG IDC WIRE TO BOARD CONNECTOR SINGLE CONTACT

SMT PCB LAYOUT

PURE TIN PADS

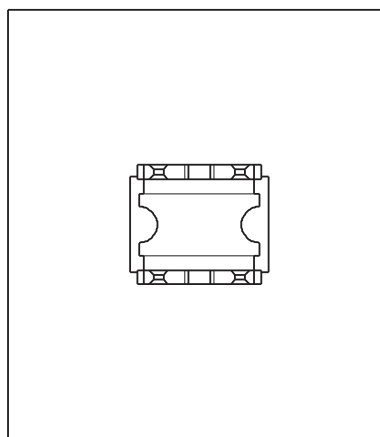
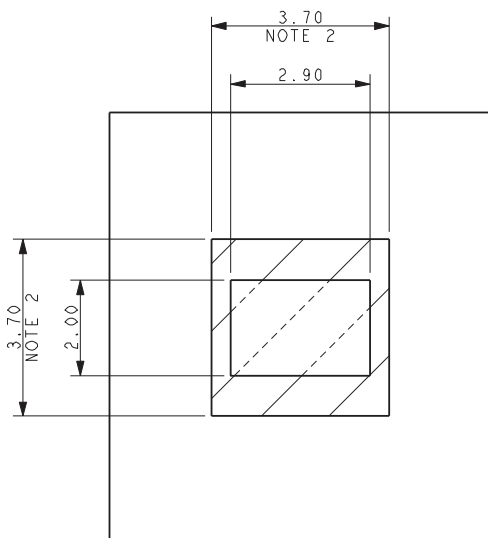

ORIENTATION OF CONTACT ON PAD

ASSEMBLED/INSTALLED PRODUCTS

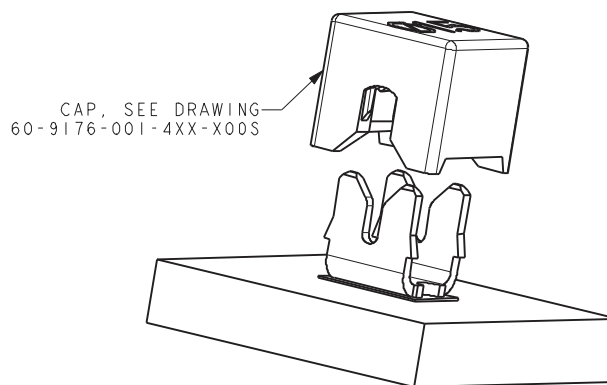
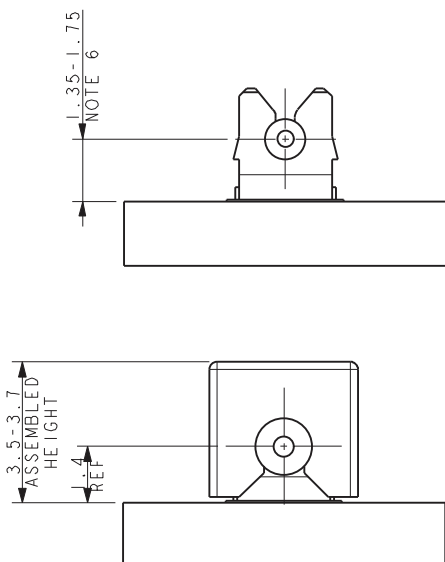

NOTES:

1. CONNECTOR CAN BE USED WITH CONTACT ONLY OR WITH OPTIONAL CAP.
2. OUTLINE OF CAP WHERE USED.
3. FOR FULL PRODUCT SPECIFICATION REFER TO ELCO SPEC 201-01-126 AND APPLICATION NOTES 201-01-124.
4. ALL DIMENSIONS ± 0.20 UNLESS TOLERANCED.
5. ASSEMBLY TOOLING ON PAGE 39 FOR WIRE INTO CONTACT AND PAGE 38 FOR CAP.
6. WIRE CENTER LINE HEIGHT ABOVE THE PCB. THIS INCLUDES AN ALLOWANCE OF 0.10MM FOR SOLDER AND 0.035MM FOR PAD THICKNESS. NO ALLOWANCE HAS BEEN MADE FOR SOLDER RESIST OR OTHER FEATURES.

SINGLE IDC CONTACT 22-28 AWG: 9176-400

Assembly Tooling

ASSEMBLY TOOLING – CAP USED

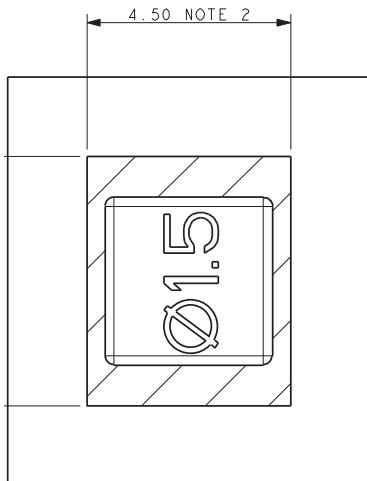

NOTES:

1. ASSEMBLY TOOLING FOR CAP.
2. MINIMUM AREA OF PCB TO BE KEPT CLEAR OF COMPONENTS, TRACKS PERMISSIBLE.
3. WIRE AND CAP INSERTED IN ONE OPERATION.
4. REFER TO APPLICATION NOTE 201-01-124 FOR FURTHER INFORMATION.
5. REFER TO PAGE 39 FOR ASSEMBLY WITHOUT CAP.

CAP APPLICATION TOOL – PLASTIC

06-9176-7023-01-000

METAL TOOL – HIGH VOLUME

06-9176-7024-01-000

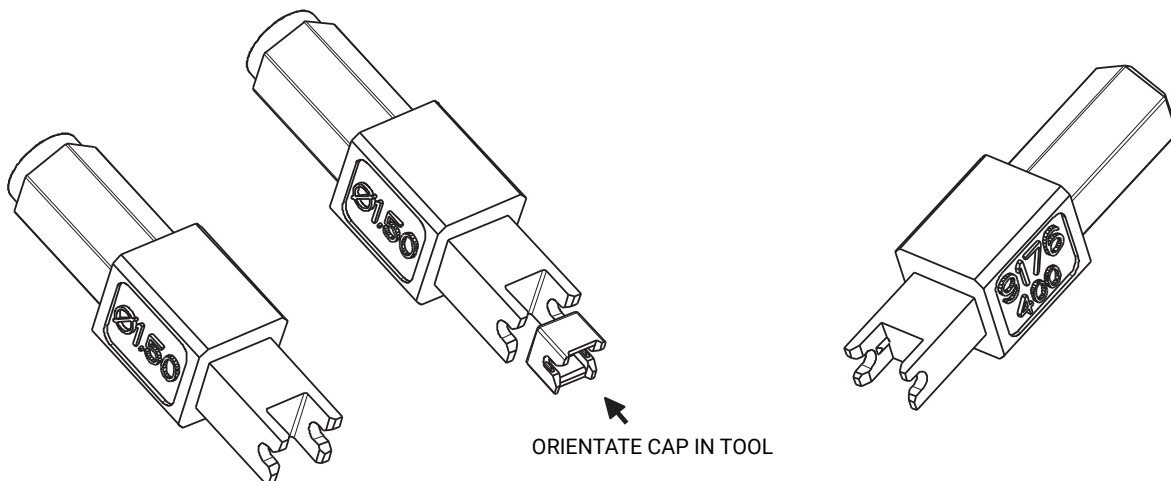

UNIVERSAL HANDLE

06-7000-7730-01-000

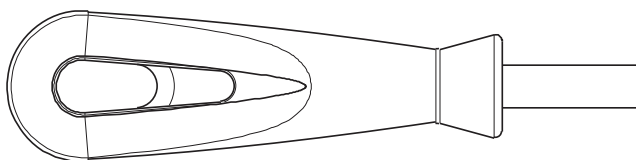

CONNECTOR/TOOLING PART NUMBER MATRIX

SERIES 9176-400 IDC				HAND INSERTION TOOLING*		ACCESSORY CAPS		
AWG	Wire Insulation	Positions	Part Number	Plastic (medium volume)	Metal (high volume)	Cap Application Tool	White	Black
22	Ø 1.0 - 1.5	1p	709176001422006	069176702201000	069176702101000	069176702301000	609176001415100	609176001415000
24	Ø 1.0 - 1.5	1p	709176001432006	069176702201000	069176702101000	069176702301000	609176001415100	609176001415000
26	Ø 0.7 - 1.0	1p	709176001442006	069176702201000	069176702101000	069176702301000	609176001415100	609176001415000
28	Ø 0.7 - 1.0	1p	709176001443006	069176702201000	069176702101000	069176702301000	609176001415100	609176001415000

* Hand Insertion Tooling and Cap Application - Universal Hand Tool 067000773001000; Consult Application Notes 201-01-124

SINGLE IDC CONTACT 22-28 AWG: 9176-400

Assembly Tooling

ASSEMBLY TOOLING – CAP NOT USED WIRE ONTO CONTACT

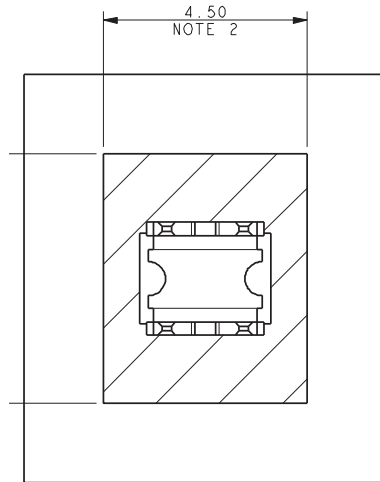

**METAL TOOL
HIGH VOLUME**
06-9176-7021-01-000

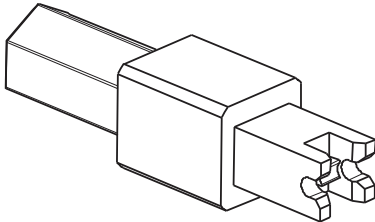

**PLASTIC TOOL
LOW/MEDIUM VOLUME**
06-9176-7022-01-000

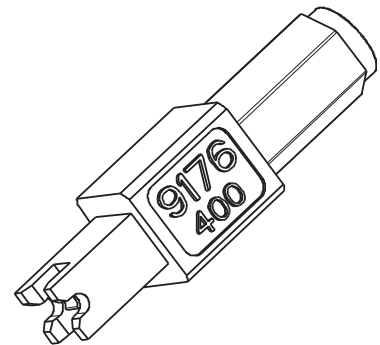

UNIVERSAL HANDLE
06-7000-7730-01-000

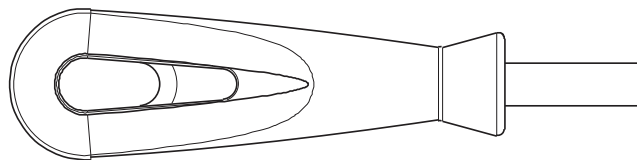

NOTES:

1. ASSEMBLY TOOLING FOR CONTACT ONLY. NO CAP USED.
2. MINIMUM AREA OF PCB TO BE KEPT CLEAR OF COMPONENTS, TRACKS PERMISSIBLE.
3. REFER TO APPLICATION NOTE 201-01-124 FOR FURTHER INFORMATION.
4. INSERT CORRECT TOOL INTO HANDLE, MAGNETIC RETENTION.
5. REFER TO PAGE 38 FOR ASSEMBLY WITH CAP.

SINGLE IDC CONTACT 22-28 AWG: 9176-400

Cap Details

CAP DETAILS

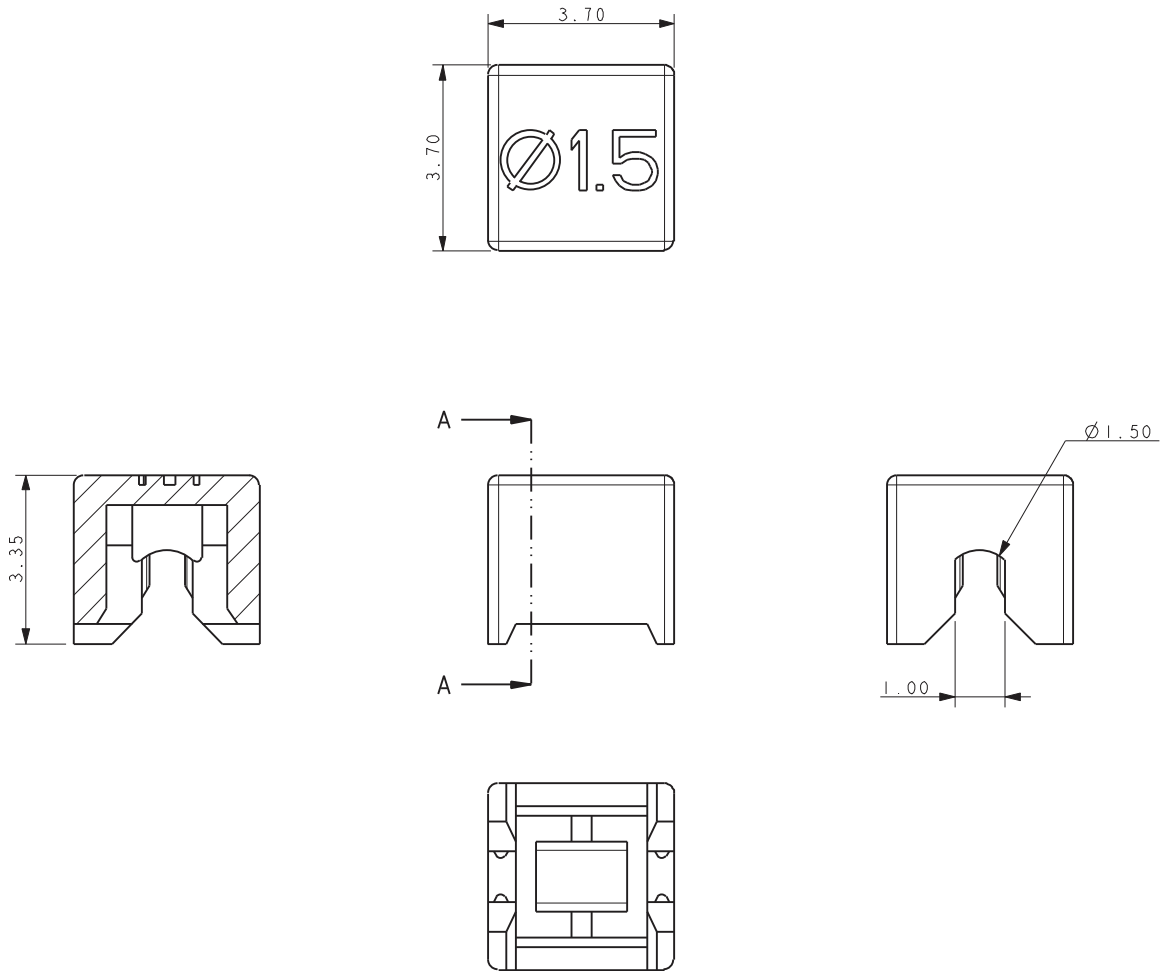

NOTES:

1. CAP FOR IDC WIRE TO BOARD CONNECTION.
2. CAP MATERIAL: GLASS FILLED NYLON 46, COLOR SEE PAGE 35.
3. CAPS DESIGNED TO ACCOMMODATE WIRE INSULATION DIAMETERS 0.75MM TO 1.5MM.
4. ALL DIMENSIONS ± 0.20 UNLESS TOLERANCED.
5. FOR FULL PRODUCT SPECIFICATION REFER TO ELCO SPEC 201-01-126, APPLICATION NOTES 201-01-124.
6. PACKING IN BAGS, QUANTITY 2000 PER BAG.
7. FOR INSTALATION DETAILS REFER TO DRAWING 70-9176-001-4XX-006S.

SINGLE IDC CONTACT 18-24 AWG: 9176-500

General Information

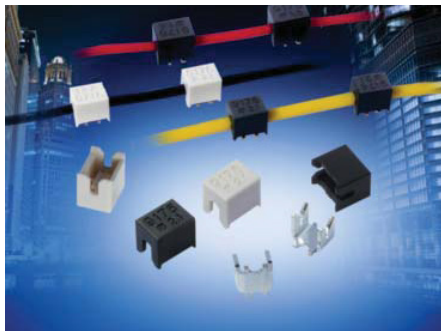

The 917X series of surface mount Insulation Displacement Connectors (IDC) were developed to meet the harsh automotive and industrial market applications for connecting individual wires directly to a PCB ranging from 14 AWG to 28 AWG. This industry proven contact system has been tested to automotive levels of shock, vibration, and temperature cycling to prove their reliability and robustness. This new single contact was developed as a standalone component to enhance the application uses with the IDC technology. The simplicity of inserting a wire into an SMT contact with a small tool or optional retention / termination cap allows a wide range of devices to be connected to the PCB without soldering. In SSL applications specifically, these contacts are used to bring power and signal onto the PCB or are used to daisy chain multiple boards together in a long string. While the IDC contact provides a gas-tight connection to conductor of the wire, the optional cap provides a positive strain relief even in the harshest conditions. In case of repair, the wires can be removed and replace up to three times.

The single 9176 series contact and cap accepts 18 AWG to 24 AWG wires with an insulation diameter ranging from 1.1mm to 2.1mm. These dual beam contacts support a 10 amp current rating with a large SMT solder base to provide maximum stability on the PCB. The optional locking strain relief cap acts as the termination tool for severe vibration applications.

APPLICATIONS

- Connecting discrete wire components directly to the PCB
- Bringing power and signals onto a PCB
- Daisy chaining PCB's together to create a continuous string of boards
- Application notes: refer to 201-01-124

FEATURES AND BENEFITS

- IDC contact is supplied in T&R pockets for standard SMT placement
- IDC contact provides a gas-tight connection to the PCB for long term reliability
- Optional termination cap provides additional strain relief for severe environments
- Tested to automotive levels on shock, vibration and temperature cycling for reliability
- Reduced total applied cost versus solder or crimp processes
- Individual contacts can be located anywhere on the PCB based on specific application

ELECTRICAL

- Current Rating: 10 Amps/Contact
- Voltage Rating: Dependant on component proximity

ENVIRONMENTAL

- Operating Temperature: -40°C to +125°C

MECHANICAL

- Insulator Material: Nylon 46: UL94V0
- Contact Material: Phosphor Bronze
- Plating: Tin over Nickel
- Durability: 3 Cycles

HOW TO ORDER – CONTACT OPTIONS

70
Prefix
70 = Contact

9176
Series

001
Number of Ways

Code	No of Ways	Details
001	1	Page 39

4XX
Wire Gauge Size

Code	Accepted Wire Gauge
501	18 Gauge Stranded
511	20 Gauge Solid or Stranded
522	22 Gauge Solid or Stranded
532	24 Gauge Solid or Stranded

006
Plating Option
006 = Pure Tin all over

HOW TO ORDER – CAP OPTIONS

60
Prefix
60 = Cap

9176
Series

001
Number of Ways

Code	No of Ways	Details
001	1	Page 43

5XX
Wire Gauge Size

Code	Wire Insulation (AWG)
516	1.1-1.6 (22-24)
521	1.6-2.1 (18-20)

X00
Insulator Color

Code	Color	Application
000	Black	Industrial
100	White	Lighting



CONNECTOR/TOOLING PART NUMBER MATRIX

SERIES 9176-500 IDC				HAND INSERTION TOOLING*		ACCESSORY CAPS		
AWG	Wire Insulation	Positions	Part Number	Plastic (medium volume)	Metal (high volume)	Cap Application Tool	White	Black
18	Ø 1.6 - 2.1	1p	709176001501006	069176702001000	069176701901000	069176701801000	609176001521100	609176001521000
20	Ø 1.6 - 2.1	1p	709176001511006	069176702001000	069176701901000	069176701801000	609176001521100	609176001521000
22	Ø 1.1 - 1.6	1p	709176001522006	069176702002000	069176701902000	069176701801000	609176001516100	609176001516000
24	Ø 1.1 - 1.6	1p	709176001532006	069176702002000	069176701902000	069176701801000	609176001516100	609176001516000

* Hand Insertion Tooling and Cap Application - Universal Hand Tool 067000773001000; Consult Application Notes 201-01-124

Certification: UL File #E90723

SINGLE IDC CONTACT 18-24 AWG: 9176-500

Contact Details

CONTACT DETAILS

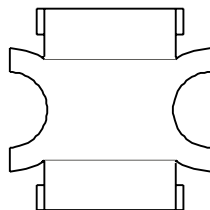
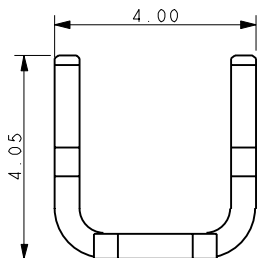
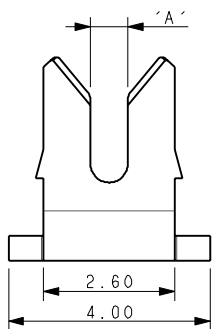

Code	Accepted Wire Gauge	A
501	18 AWG Stranded	0.74
511	20 AWG Solid and Stranded	0.60
522	22 AWG Solid and Stranded	0.47
532	24 AWG Solid and Stranded	0.37

NOTES:

- CONNECTOR FOR IDC WIRE TO BOARD CONNECTION.
- CONTACT MATERIAL: PHOSPHOR BRONZE.
- CONTACT PLATING: PURE TIN.
- CONNECTOR DESIGNED TO ACCEPT BETWEEN 20AWG AND 24AWG SOLID AND STRANDED WIRES, 18AWG WILL ONLY ACCEPT STRANDED WIRES, SEE TABLE.
- ALL DIMENSIONS ± 0.20 UNLESS TOLERANCED
- FOR FULL PRODUCT SPECIFICATION REFER TO ELCO SPEC 201-01-126 AND APPLICATION NOTES 201-01-124.
- SMT PCB LAYOUT, REFER TO SHEET 3.
- PACKING IN TAPE AND REEL, QUANTITY 1000 PER REEL.
- WHEN REQUIRED, MATCHING CAP DETAILS ON DRAWING 60-9176-001-5XX-X00S
- ASSEMBLY TOOLING ON SHEETS 4 (WITH CAP) AND 5 (WITHOUT CAP).

AREA AVAILABLE FOR PICK & PLACE 2.00mm SQUARE

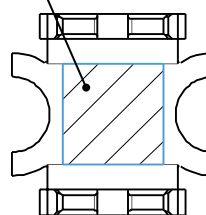

PACKING DETAILS

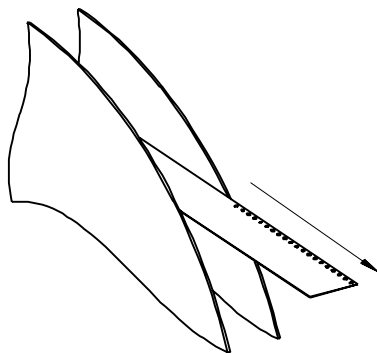

REEL QTY	1000
LEADER	480mm
TRAILER	120mm

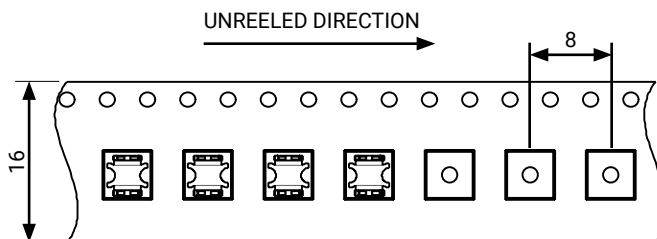

SINGLE IDC CONTACT 18-24 AWG: 9176-500

PBC Layout

18-24 AWG IDC WIRE TO BOARD CONNECTOR SINGLE CONTACT

SMT PCB LAYOUT PURE TIN PADS

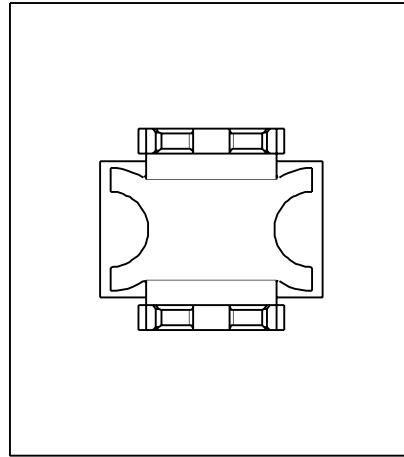
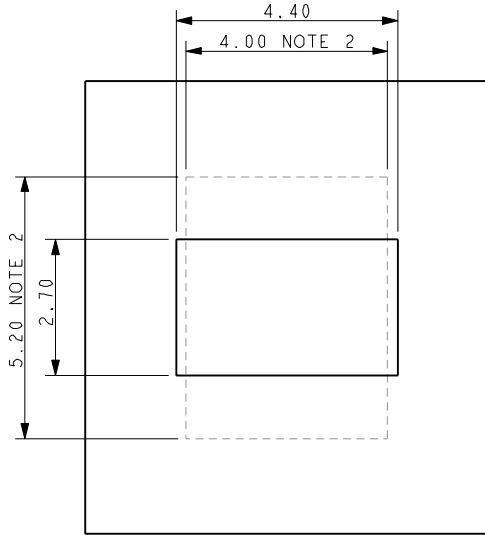

ORIENTATION OF CONTACT ON PAD

ASSEMBLED/INSTALLED PRODUCTS

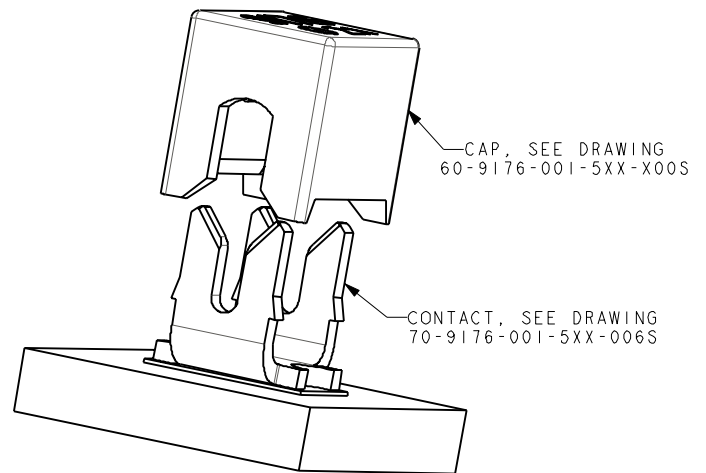
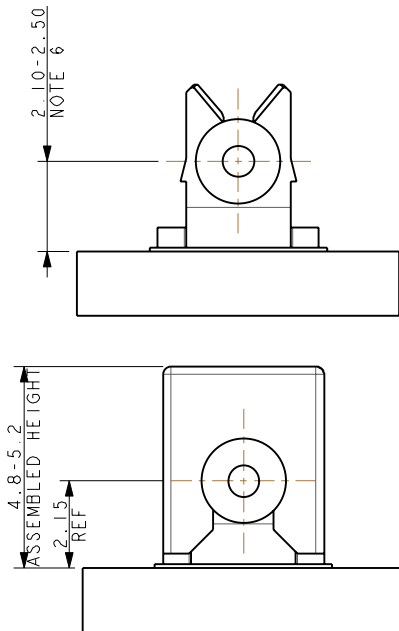

NOTES:

1. CONNECTOR CAN BE USED WITH CONTACT ONLY OR WITH OPTIONAL CAP.
2. OUTLINE OF CAP WHEN USED.
3. FOR FULL PRODUCT SPECIFICATION REFER TO ELCO SPEC 201-01-126 AND 201-01-124.
4. ALL DIMENSIONS ± 0.20 UNLESS TOLERANCED.
5. ASSEMBLY TOOLING ON SHEETS 4 (WITH CAP) AND 5 (WITHOUT CAP).
6. WIRE CENTRE LINE HEIGHT ABOVE THE PCB, THIS INCLUDES AN ALLOWANCE OF 0.10MM FOR SOLDER AND

SINGLE IDC CONTACT 18-24 AWG: 9176-500

Assembly Tooling

ASSEMBLY TOOLING – CAP USED

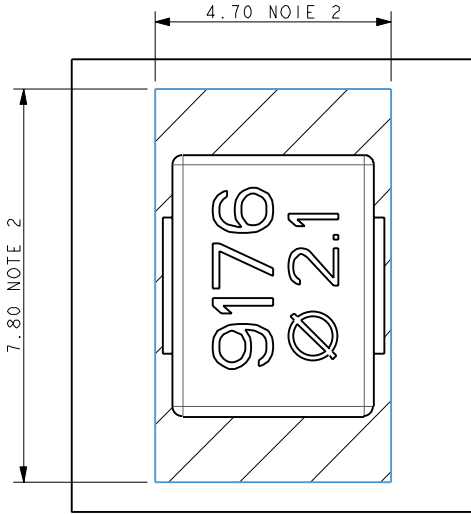

NOTES:

1. ASSEMBLY TOOLING FOR CAP.
2. AREA OF PCB TO BE KEPT CLEAR OF COMPONENTS, TACKS PERMISSIBLE.
3. WIRE AND CAP INSERTED IN ONE OPERATION.
4. REFER TO APPLICATION NOTE 201-01-124 FOR FURTHER INFORMATION.
5. REFER BELOW WHEN CONTACT USED WITHOUT CAP.

06-9176-7018-01-000
CAP APPLICATION TOOL
PLASTIC

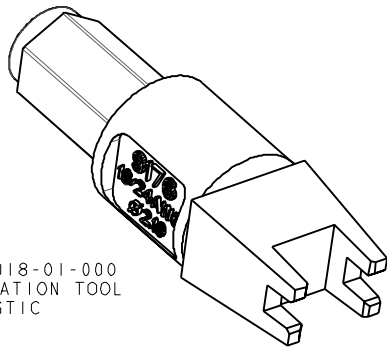

06-9176-7025-01-000
CAP APPLICATION TOOL
METAL

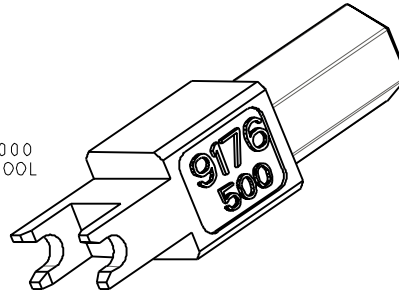

ORIENTATE CAP IN TOO

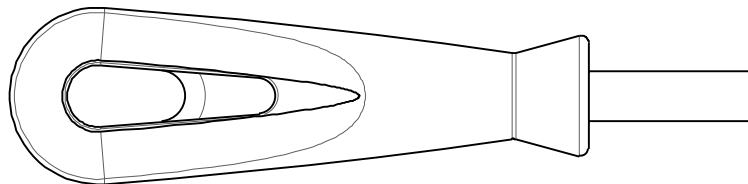

06-7000-7730-01-000
UNIVERSAL HANDLE

SINGLE IDC CONTACT 18-24 AWG: 9176-500

Assembly Tooling

ASSEMBLY TOOLING – CAP NOT USED WIRE ONTO CONTACT

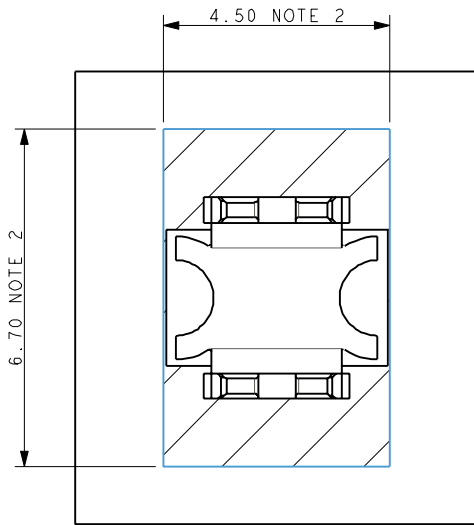

NOTES:

1. ASSEMBLY TOOLING FOR CONTACT ONLY, NO CAP USED.
2. MINIMUM AREA OF PCB TO BE KEPT CLEAR OF COMPONENTS, TRACKS PERMISSIBLE.
3. REFER TO TABLE FOR CORRECT TOOL/WIRE COMBINATION.
4. REFER TO APPLICATION NOTE 201-01-124 FOR FURTHER INFORMATION

WIRE INSULATION Ø	METAL TOOL HIGH VOLUME	PLASTIC TOOL SMALL TO MEDIUM VOLUME	HANDLE
1.10 to 1.60	06-9176-7019-02-000	06-9176-7020-02-000	06-7000-7730-01-000
1.60 to 2.10	06-9176-7019-01-000	06-9176-7020-01-000	06-7000-7730-01-000

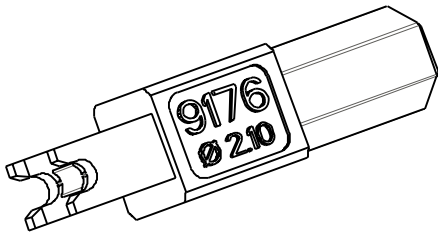

06-9176-7019-01-000
06-9176-7020-01-000
2.1Ø WIRE

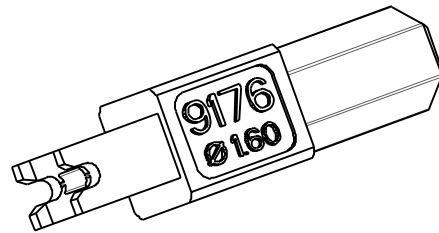

06-9176-7019-02-000
06-9176-7020-02-000
1.6Ø WIRE

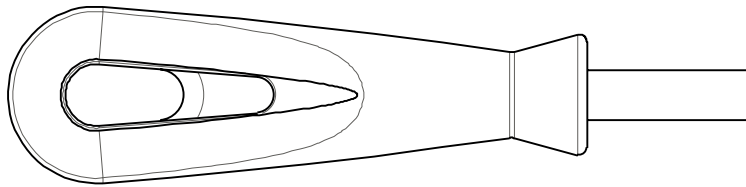

06-7000-7730-01-000
UNIVERSAL HANDLE

SINGLE IDC CONTACT 18-24 AWG: 9176-500

Cap Details

CAP DETAILS

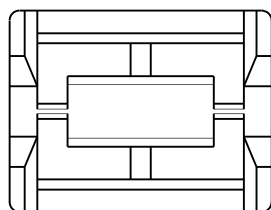
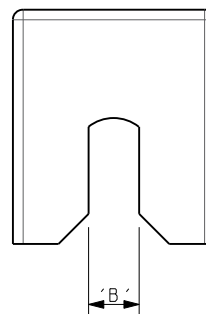
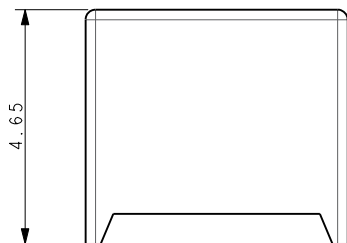
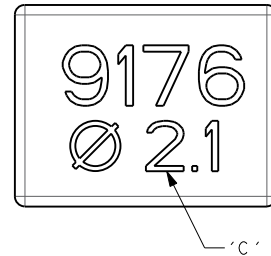
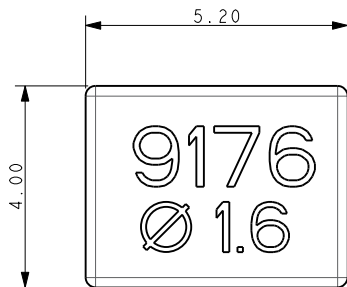

Code	Insulator Diameter (AWG)	B	Text C
516	1.1 to 1.6 (22-24)	1.00	Ø 1.6
521	1.6 to 2.1 (18-20)	1.50	Ø 2.1

NOTES:

1. CAP FOR IDC WIRE TO BOARD CONNECTION.
2. CAP MATERIAL: GLASS FILLED NYLON 46, COLOR SEE PAGE 41.
3. CAPS DESIGNED TO ACCOMMODATE WIRE INSULATION DIAMETERS 1.1MM TO 2.1MM.
4. ALL DIMENSIONS FOR REFERENCE UNLESS OTHERWISE STATED.
5. FOR FULL PRODUCT SPECIFICATION REFER TO ELCO SPEC 201-01-106, APPLICATION NOTES 201-01-124.
6. PACKING IN BAGS, QUANTITY 1000 PER BAG.
7. FOR INSTALATION DETAILS REFER TO DRAWING 70-9176-001-XX-006S.

SINGLE IDC CONTACT 12-18 AWG: 9177-500

General Information



GENERAL DESCRIPTION

AVX's STRIPT™, insulation displacement naked contact technology provides cost effective, insulator-less, wire-to-board connection for discrete wire applications. Designed from the ground up to function just like a traditional insulated connector, these UL certified contacts have been industry proven for many years. This 9177-500 series has been designed to support the larger wire gauges from a robustness and current rating perspective.

APPLICATIONS

- Industrial motor controls, drives & pumps
- Commercial building wiring and electrical systems
- Outdoor/Transportation lighting
- Solar and alternative energy

ELECTRICAL

- Current Rating: 15
- Voltage Rating: 600 VAC

ENVIRONMENTAL

- Operating Temperature: -40°C to +125°C

HOW TO ORDER

70	9177	001	5XX	006	
Prefix	Series	No. of Ways 001 = 1	Description 591 = 12AWG Stranded and Solid 501 = 14AWG Stranded and Solid 512 = 16AWG Stranded and Solid 522 = 18AWG Stranded and Solid	Plating 006 = Pure Tin all over	

Certification: UL File #E90723

FEATURES AND BENEFITS

- Proven "gas tight" cold welded wire termination
- Redundant contact systems provides enhanced wire retention and high current carrying capabilities
- Cost effective STRIPT™ insulator-less contact system

MECHANICAL

- Contact Material: Phosphor Bronze
- Contact Plating: Pure tin over nickel
- Durability: 3 termination cycles

SINGLE IDC CONTACT 12-18 AWG: 9177-500

Contact Detail

CONTACT DETAIL

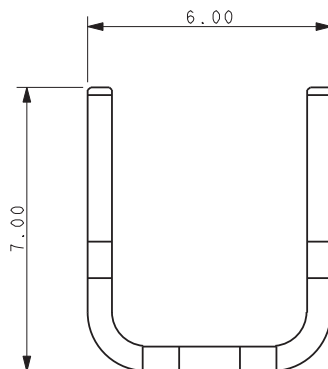
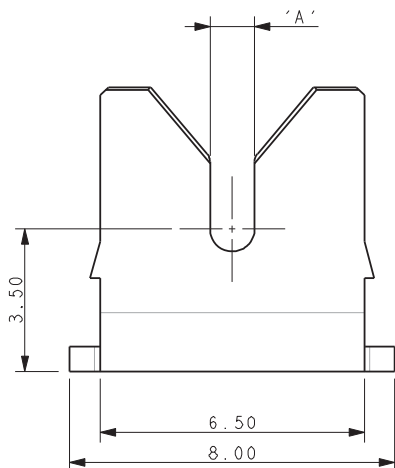

Code	Accepted Wire Gauge	A
591	12AWG Stranded and Solid	1.50
501	14AWG Stranded and Solid	1.10
512	16AWG Stranded and Solid	0.82
522	18AWG Stranded and Solid	0.72

NOTES:

- CONNECTOR FOR IDC WIRE TO BOARD CONNECTION.
- CONTACT MATERIAL: PHOSPHORE BRONZE.
- CONTACT PLATING: PURE TIN.
- CONTACTS DESIGNED TO ACCEPT BETWEEN 12 AND 18 GAUGE STANDED WIRE, SEE TABLE.
- ALL DIMENSIONS FOR REFERENCE UNLESS OTHERWISE STATED.
- FOR FULL PRODUCT SPECIFICATIONS REFER TO AVX SPECIFICATION 201-01-208 AND APPLICATION NOTES 201-01-209.
- SMT PCB LAYOUT, REFER TO PAGE 3.
- PACKING IN TAPE AND REEL, QUANTITY PER REEL 700.
- ASSEMBLY TOOLING ON PAGE 4.
- UL REFERENCE E90723 (US AND CANADA).

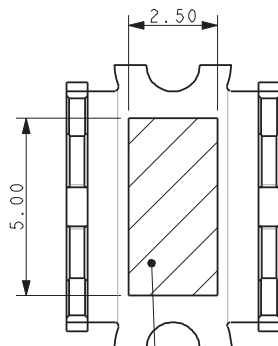

PICK AND PLACE AREA

PACKING DETAILS

REEL QTY	700
LEADER	480MM
TRAILER	120MM

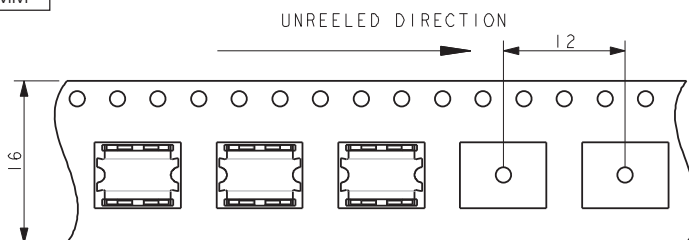
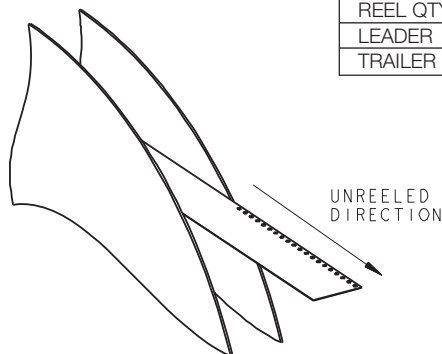

SINGLE IDC CONTACT 12-18 AWG: 9177-500

IDC Wire to Board Connector Single Contact

12-18 AWG IDC WIRE TO BOARD CONNECTOR SINGLE CONTACT

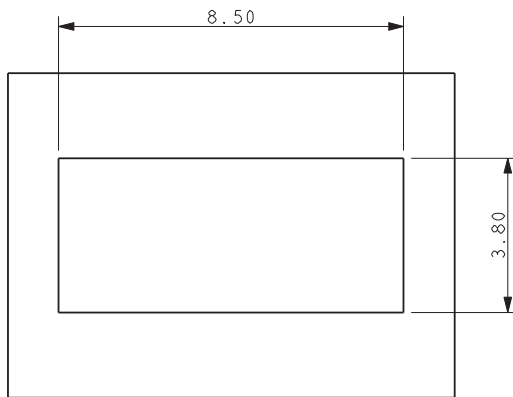

SUGGESTED PCB LAYOUT

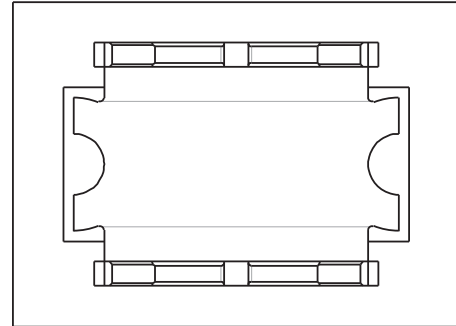

ORIENTATION OF CONTACT ON PAD

NOTES:

1. FOR FULL PRODUCT SPECIFICATION REFER TO AVX SPEC 201-01-208 AND 201-01-209
2. DIMENSIONS SHOWN ARE REFERENCE DIMENSIONS.
3. ASSEMBLY TOOLING ON PAGE 4.

SINGLE IDC CONTACT 12-18 AWG: 9177-500

Assembly Tooling

ASSEMBLY TOOLING

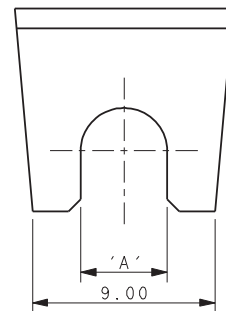
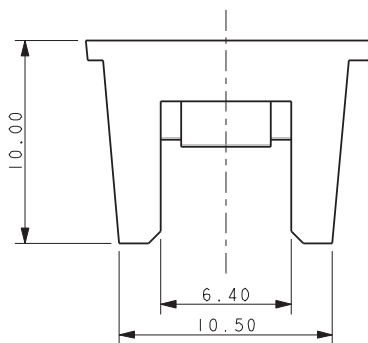
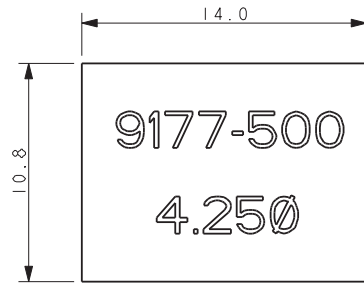

Wire Gauge	Max Insulation (Dimensions 'A')	Tool Number Metal Tool for High Volume	Tool Number Plastic Tool for Small to Medium Volume
12-18 AWG	Ø 4.25	06-9177-7020-01-001	06-9177-7022-01-001
12-18 AWG	Ø 3.50	06-9177-7020-02-001	06-9177-7022-02-001
12-18 AWG	Ø 2.75	06-9177-7020-03-001	06-9177-7022-03-001

NOTES:

1. ASSEMBLY TOOLING FOR CONTACTS 70-9177-001-5XX-006 ONLY.
2. MINIMUM AREA OF PCB TO BE KEPT CLEAR OF COMPONENTS. TRACKS PERMISSIBLE.
3. MAXIMUM COMPONENT HEIGHT 9.0MM IN THIS AREA.
4. REFER TO TABLE FOR CORRECT TOOL/WIRE COMBINATION.
5. REFER TO APPLICATION NOTE 201-01-209 FOR FURTHER INFORMATION.
6. DIMENSIONS FOR TOOL ARE REFERENCE DIMENSIONS.

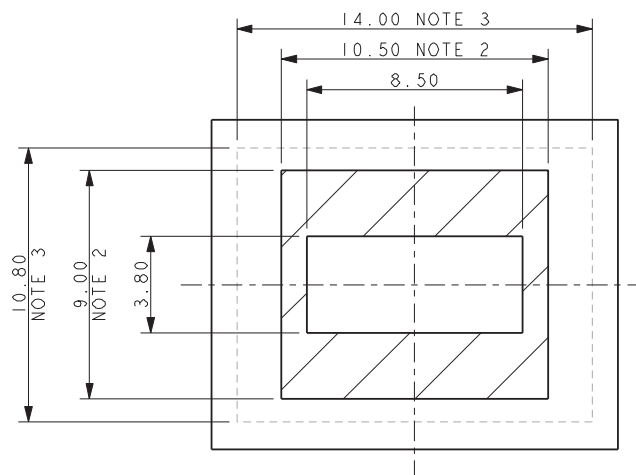

SINGLE TINE PTH 18-24 AWG: 9176-600

General Information

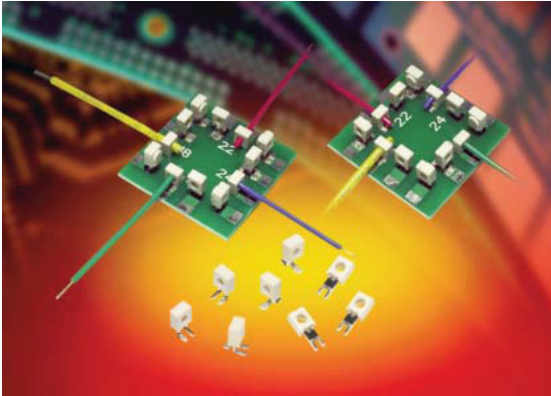

The market and applications for simple and reliable discrete Wire-to-Board (WTB) connectors continue to evolve. Developed for harsh industrial and automotive applications, Insulation Displacement Connectors (IDC) have been used in hundreds of applications connecting wires to PCB's from transportation wiring to every day LED lighting and smart meter/sensor connections. Size, performance and simplicity have been the key factors for selecting this connector when long term reliability is critical.

This single contact version of the proven 9176 family of connectors is the first in Plated Through Hole (PTH) termination. While supporting all of the features and benefits from the SMT offering, this connector provides a new option for a small, cost effective and high performance WTB solution.

APPLICATIONS

- Machine Controls: motors, drives, solenoids, sensors, fans and pumps
- Commercial Buildings: controls, security, fire and sensors
- Smart Grid: meters, breakers and panels
- SSL/LED: bulbs, fixtures, signage and streetlights
- Application notes: reference 201-01-142

FEATURES AND BENEFITS

- IDC contact provides a gas-tight connection to the PCB for long term reliability
- Plastic cap retains the contact and then acts as the assembly tool to terminate the wires; no special tooling.
- Tested to automotive levels on shock, vibration and temperature cycling for reliability
- The IDC contact reduces the total applied cost versus solder or crimp processes
- Connectors are available in two configurations for maximum flexibility: End and Through Wire

ELECTRICAL

- Current Rating: See matrix below
- Voltage Rating: 600 VAC

ENVIRONMENTAL

- Operating Temperature: -40°C to +125°C

MECHANICAL

- Contact Material: Phosphor Bronze
- Contact Plating: Tin over Nickel
- Durability: 3 Cycles

HOW TO ORDER

00 **9176** **001**
 Prefix Series Number of Ways
 001 = 1

60X
 Contact Style

Code	Description	Accepted Wire Gauge	Wire Gauges
600	Capped IDC Connector PTH PCB Mount	18 AWG Stranded	ø1.6-2.1
601		20 AWG Solid and Stranded	ø1.6-2.1
602		22 AWG Solid and Stranded	ø1.1-1.6
603		24 AWG Solid and Stranded	ø1.1-1.6

9
 Color Option
 9 = UL White

X
 Cap Options

Code	Cap Option	Description	Details
0	Through Wire	Allows wire to be terminated at any point	See page 47
9	Wire Stop	Terminates end of wire End protected by stop face	See page 48

6
 Plating Option
 Tin Plated

CURRENT RATING

18AWG	20AWG	22AWG	24AWG
9A	8A	6A	5A

Certification: UL File #E90723



SINGLE TINE PTH 18-24 AWG: 9176-600

1 Position - Through Wire

18-24 AWG 1 WAY PTH CONNECTOR THROUGH WIRE CAPPED

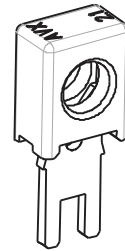
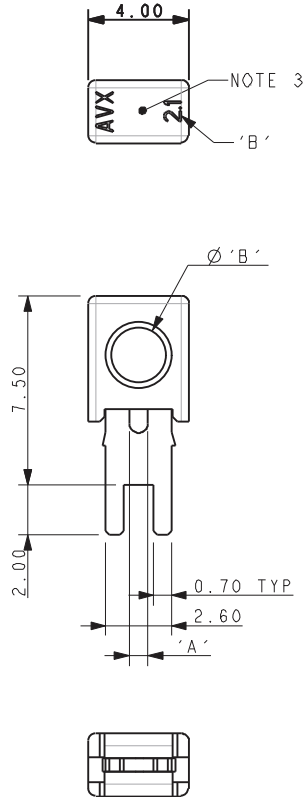

Code	Accepted Wire Gauge	A	Wire Insulation	B
600	18 AWG Stranded	0.74	ϕ 1.6-2.1	2.1
601	20 AWG Solid or Stranded	0.60	ϕ 1.6-2.1	2.1
602	22 AWG Solid or Stranded	0.47	ϕ 1.1-1.6	1.6
603	24 AWG Solid or Stranded	0.37	ϕ 1.1-1.6	1.6

SUGGESTED PCB LAYOUT

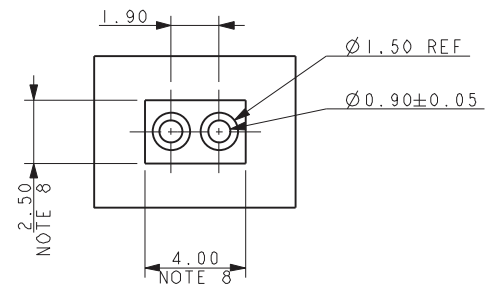

PACKING DETAILS

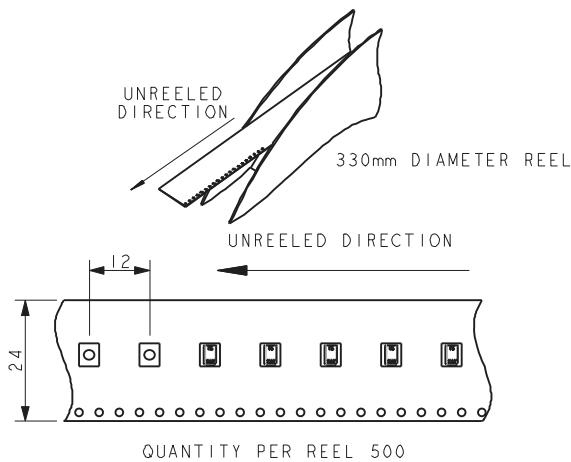

NOTES:

1. 1 WAY CONNECTOR FOR PTH WIRE TO BOARD CONNECTION, PRE-ASSEMBLED THROUGH WIRE CAP, CODE SEE PAGE 46.
2. CONTACT/CAP TO MATCH 20AWG-24AWG SOLID AND STRANDED WIRES, 18AWG WILL ONLY ACCEPT STRANDED WIRES, SEE TABLE.
3. FLAT FACE ON TOP OF CAP TO AID PICK AND PLACE ASSEMBLY, MAXIMUM DIAMETER 1.8MM.
4. FOR FULL PRODUCT SPECIFICATION ON STANDARD CONNECTORS REFER TO ELCO SPEC 201-01-163.
5. ASSEMBLY PROCEDURE, REFER TO APPLICATION NOTES 201-01-142.
6. GENERAL TOLERANCE \pm 0.20 UNLESS STATED.
7. PACKED IN TAPE AND REEL, QUANTITY PER REEL 500.
8. CONNECTOR OUTLINE.
9. CONTACT MATERIAL: TIN PLATED COPPER ALLOY.
10. INSULATION MATERIAL: HIGH TEMPERATURE NYLON, GLASS FILLED, UL94 V-O. COLOR REFER TO PAGE 46.

SINGLE TINE PTH 18-24 AWG: 9176-600

1 Position - Wire Stop

18-24 AWG 1 WAY PTH CONNECTOR WIRE STOP CAPPED

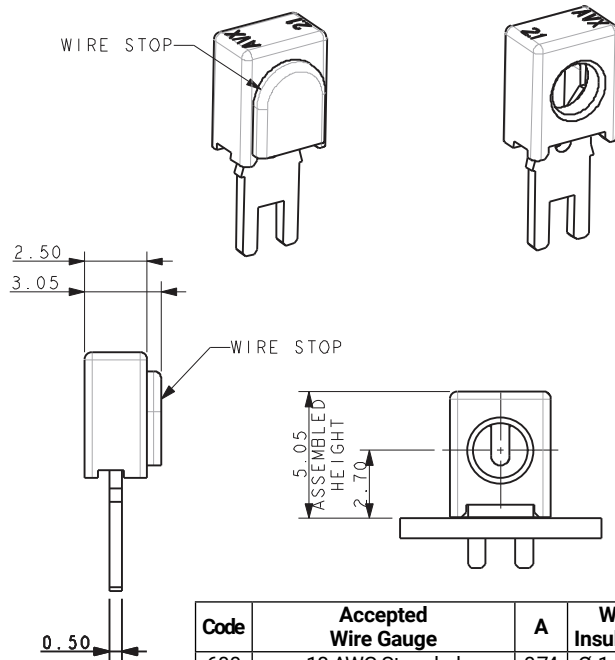
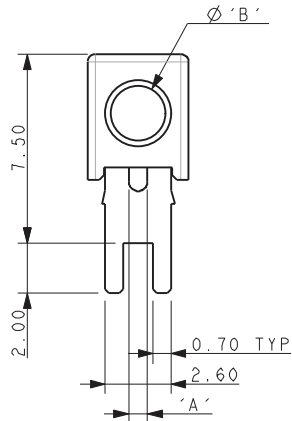
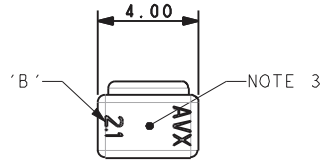

Code	Accepted Wire Gauge	A	Wire Insulation	B
600	18 AWG Stranded	0.74	ϕ 1.6-2.1	2.1
601	20 AWG Solid or Stranded	0.60	ϕ 1.6-2.1	2.1
602	22 AWG Solid or Stranded	0.47	ϕ 1.1-1.6	1.6
603	24 AWG Solid or Stranded	0.37	ϕ 1.1-1.6	1.6

SUGGESTED PCB LAYOUT

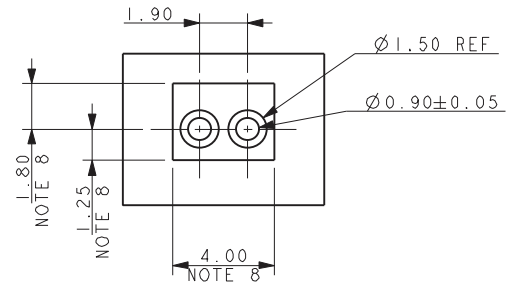

PACKING DETAILS

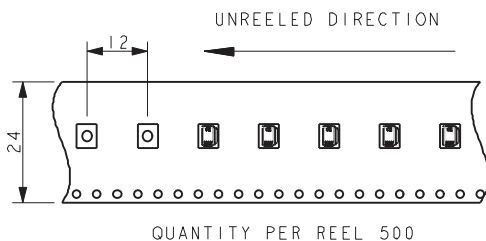
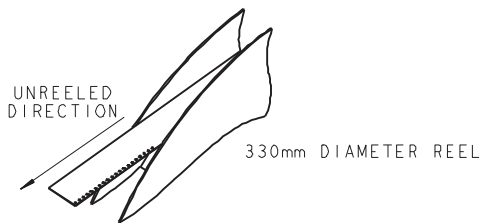

NOTES:

- 1 WAY CONNECTOR FOR PTH WIRE TO BOARD CONNECTION, PRE-ASSEMBLED WIRE STOP CAP, CODE SEE PAGE 46.
- CONTACT/CAP TO MATCH 20AWG-24AWG SOLID AND STRANDED WIRES, 18AWG WILL ONLY ACCEPT STRANDED WIRES, SEE TABLE.
- FLAT FACE ON TOP OF CAP TO AID PICK AND PLACE ASSEMBLY, MAXIMUM DIAMETER 1.8MM.
- FOR FULL PRODUCT SPECIFICATION ON STANDARD CONNECTORS REFER TO ELCO SPEC 201-01-163.
- ASSEMBLY PROCEDURE, REFER TO APPLICATION NOTES 201-01-142.
- GENERAL TOLERANCE ± 0.20 UNLESS STATED.
- PACKED IN TAPE AND REEL, QUANTITY PER REEL 500.
- CONNECTOR OUTLINE.
- CONTACT MATERIAL: TIN PLATED COPPER ALLOY.
- INSULATION MATERIAL: HIGH TEMPERATURE NYLON, GLASS FILLED, UL94 V-0. COLOR REFER TO PAGE 46.
- WIRE STOP CAP PROTECTS END OF WIRE.

SINGLE TINE PTH 18-24 AWG: 9176-600

Assembly - Through Wire and Wire Stop

18-24 AWG ASSEMBLED CAPPED PTH CONNECTORS

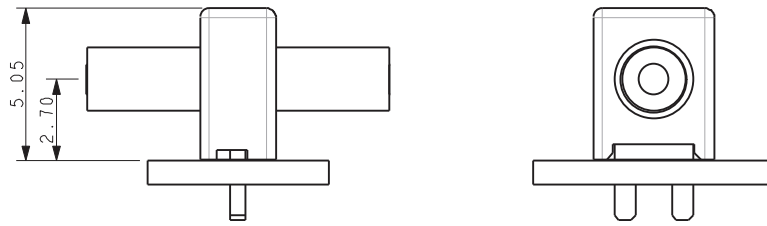

NOMINAL ASSEMBLED HEIGHTS



TYPICAL THROUGH WIRE ASSEMBLIES



TYPICAL WIRE STOP ASSEMBLIES

SINGLE TINE SMT 18-24 AWG: 9176-650

General Information

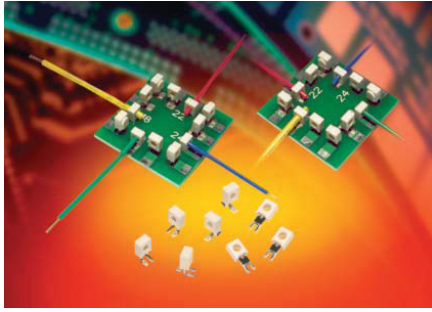

The market and applications for simple and reliable discrete Wire-to-Board (WTB) connectors continue to evolve. Developed for harsh industrial and automotive applications, Insulation Displacement Connectors (IDC) have been used in hundreds of applications connecting wires to PCB's from transportation wiring to every day LED lighting and smart meter/sensor connections. Size, performance and simplicity have been the key factors for selecting this connector when long term reliability is critical.

This single contact version of the proven 9176 family of connectors offers a lower cost solution to the market with only a 10% reduction in current rating. The SMT footprint is backward compatible with the standard dual contact configurations; offers all the same wire gauges and termination benefits of the integrated cap and provides a 10% height reduction.

APPLICATIONS

- Machine Controls: motors, drives, solenoids, sensors, fans and pumps
- Commercial Buildings: controls, security, fire and sensors
- Smart Grid: meters, breakers and panels
- SSL/LED: bulbs, fixtures, signage and streetlights
- Application notes: reference 201-01-142

FEATURES AND BENEFITS

- IDC contact provides a gas-tight connection to the PCB for long term reliability
- Plastic cap retains the contact in position prior to automatic placement, then acts as the assembly tool to terminate the wires; no special tooling.
- Tested to automotive levels on shock, vibration and temperature cycling for reliability
- Identical contact and footprint pattern to the existing 9176 for full backward compatibility and functionality
- The IDC contact reduces the total applied cost versus solder or crimp processes
- Connectors are available in two configurations for maximum flexibility: End and Through Wire

ELECTRICAL

- Current Rating: See matrix below
- Voltage Rating: 600 VAC

ENVIRONMENTAL

- Operating Temperature: -40°C to +125°C

MECHANICAL

- Contact Material: Phosphor Bronze
- Contact Plating: Tin over Nickel
- Durability: 3 Cycles

HOW TO ORDER

00 **9176** **001**
 Prefix Series Number of Ways
 001 = 1

65X
 Contact Style

9
 Color Option
 9 = UL White

X
 Cap Options

6
 Plating Option
 Tin Plated

Code	Description	Accepted Wire Gauge	Wire Gauges
650	Capped IDC Connector SMT Mount	18 AWG Stranded	ø1.6-2.1
651		20 AWG Solid and Stranded	ø1.6-2.1
652		22 AWG Solid and Stranded	ø1.1-1.6
653		24 AWG Solid and Stranded	ø1.1-1.6

Code	Cap Option	Description	Details
0	Through Wire	Allows wire to be terminated at any point	See page 51
9	Wire Stop	Terminates end of wire End protected by stop face	See page 52

CURRENT RATING

18AWG	20AWG	22AWG	24AWG
9A	8A	6A	5A

Certification: UL File #E90723



SINGLE TINE SMT 18-24 AWG: 9176-650

1 Position - Through Wire

18-24 AWG 1 WAY IDC CONNECTOR THROUGH WIRE CAPPED

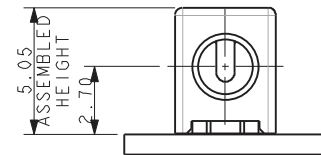
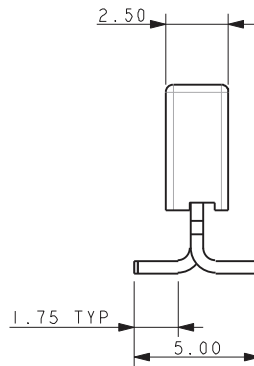
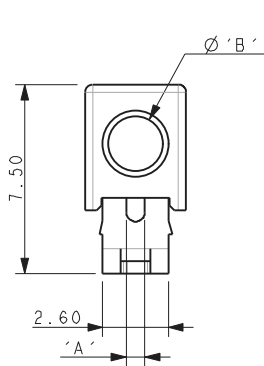
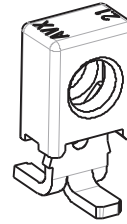
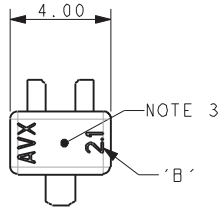

Code	Accepted Wire Gauge	A	Wire Insulation	B
600	18 AWG Stranded	0.74	Ø 1.6-2.1	2.1
601	20 AWG Solid or Stranded	0.60	Ø 1.6-2.1	2.1
602	22 AWG Solid or Stranded	0.47	Ø 1.1-1.6	1.6
603	24 AWG Solid or Stranded	0.37	Ø 1.1-1.6	1.6

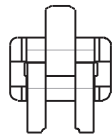

PACKING DETAILS

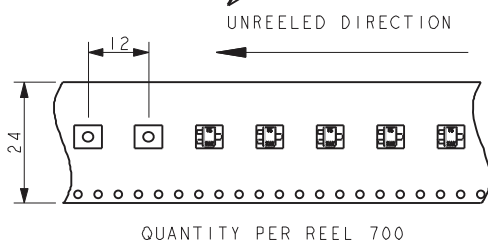
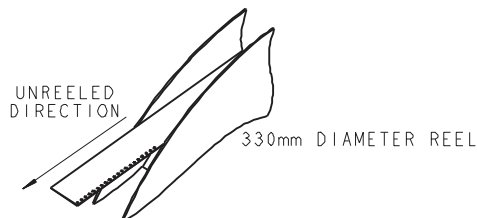

SUGGESTED PCB LAYOUT

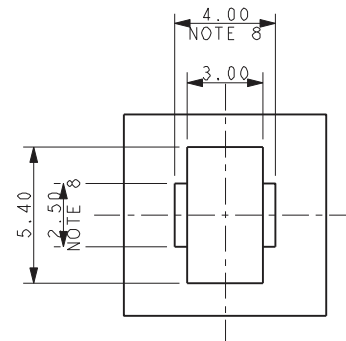

NOTES:

- 1 WAY CONNECTOR FOR IDC WIRE TO BOARD CONNECTION, PRE-ASSEMBLED THROUGH WIRE CAP, CODE SEE PAGE 50.
- CONTACT/CAP TO MATCH 20AWG-24AWG SOLID AND STRANDED WIRES, 18AWG WILL ONLY ACCEPT STRANDED WIRES, SEE TABLE.
- FLAT FACE ON TOP OF CAP TO AID PICK AND PLACE ASSEMBLY, MAXIMUM DIAMETER 1.8MM.
- FOR FULL PRODUCT SPECIFICATION ON STANDARD CONNECTORS REFER TO ELCO SPEC 201-01-163.
- ASSEMBLY PROCEDURE, REFER TO APPLICATION NOTES 201-01-142.
- GENERAL TOLERANCE ± 0.20 UNLESS STATED.
- PACKED IN TAPE AND REEL, QUANTITY PER REEL 700.
- CONNECTOR OUTLINE.
- CONTACT MATERIAL: TIN PLATED COPPER ALLOY.
- INSULATION MATERIAL: HIGH TEMPERATURE NYLON, GLASS FILLED, UL94 V-0. COLOR REFER TO PAGE 50.

SINGLE TINE SMT 18-24 AWG: 9176-650

1 Position - Wire Stop

18-24 AWG 1 WAY IDC CONNECTOR WIRE STOP CAPPED

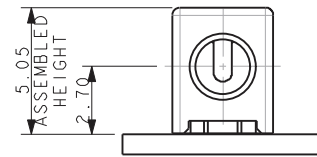
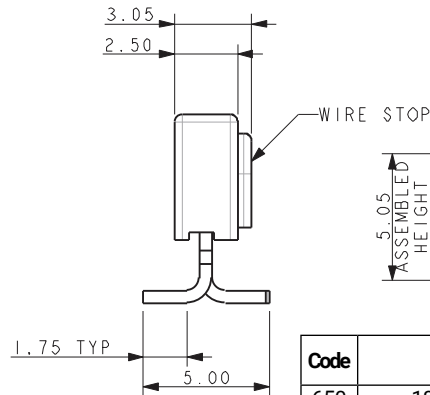
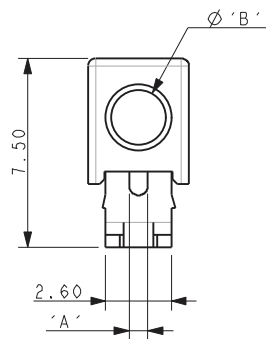
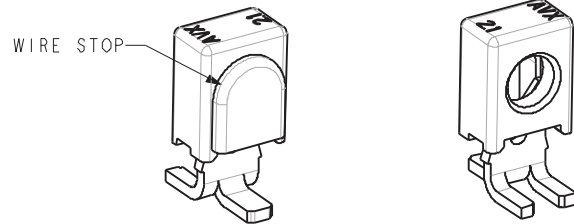
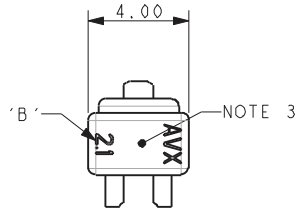

Code	Accepted Wire Gauge	A	Wire Insulation	B
650	18 AWG Stranded	0.74	Ø 1.6-2.1	2.1
651	20 AWG Solid or Stranded	0.60	Ø 1.6-2.1	2.1
652	22 AWG Solid or Stranded	0.47	Ø 1.1-1.6	1.6
653	24 AWG Solid or Stranded	0.37	Ø 1.1-1.6	1.6

SUGGESTED PCB LAYOUT

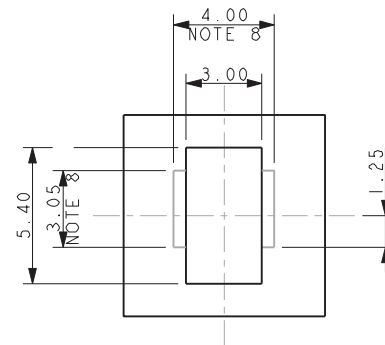
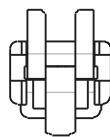

PACKING DETAILS

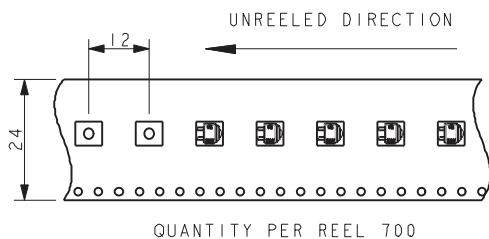
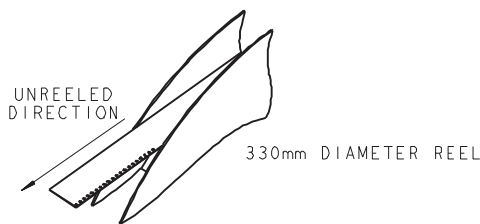

NOTES:

- 1 WAY CONNECTOR FOR IDC WIRE TO BOARD CONNECTION, PRE-ASSEMBLED WIRE STOP CAP, CODE SEE PAGE 50.
- CONTACT/CAP TO MATCH 20AWG-24AWG SOLID AND STRANDED WIRES, 18AWG WILL ONLY ACCEPT STRANDED WIRES, SEE TABLE.
- FLAT FACE ON TOP OF CAP TO AID PICK AND PLACE ASSEMBLY, MAXIMUM DIAMETER 1.8MM.
- FOR FULL PRODUCT SPECIFICATION ON STANDARD CONNECTORS REFER TO ELCO SPEC 201-01-163.
- ASSEMBLY PROCEDURE, REFER TO APPLICATION NOTES 201-01-142.
- GENERAL TOLERANCE ± 0.20 UNLESS STATED.
- PACKED IN TAPE AND REEL, QUANTITY PER REEL 700.
- CONNECTOR OUTLINE.
- CONTACT MATERIAL: TIN PLATED COPPER ALLOY.
- INSULATION MATERIAL: HIGH TEMPERATURE NYLON, GLASS FILLED, UL94 V-0. COLOR REFER TO PAGE 50.
- WIRE STOP CAP PROTECTS END OF WIRE.

SINGLE TINE SMT 18-24 AWG: 9176-650

Assembly - Through Wire and Wire Stop

18-24 AWG ASSEMBLED CAPPED IDC CONNECTORS

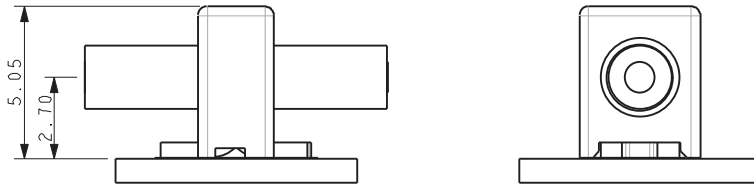

NOMINAL ASSEMBLED HEIGHTS

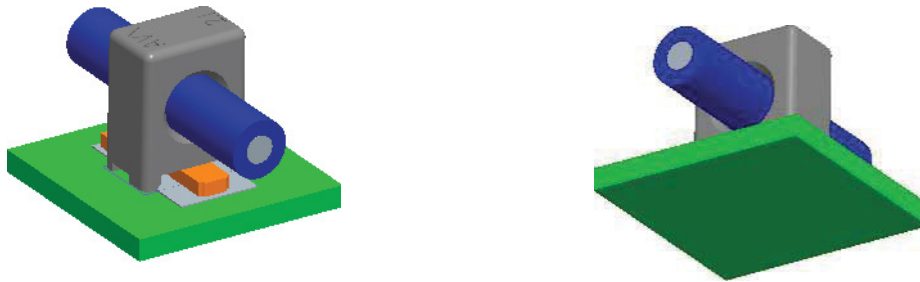

TYPICAL THROUGH WIRE ASSEMBLIES



TYPICAL WIRE STOP ASSEMBLIES

LOW PROFILE IDC 22-30 AWG: 9176-800

General Information

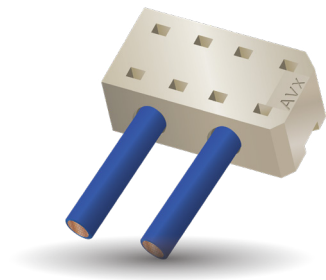

GENERAL DESCRIPTION

KYOCERA AVX industrial/transportation grade insulation displacement connectors (IDC) have been proven in the market for over ten years. Providing a very simple one-step termination process, these connectors proved a robust wire-to-board (WTB) termination in harsh applications.

The 9176-800 series has been developed specifically for 22-26AWG discrete wires in size critical applications. By reducing the "Z" axis height by 1.0mm and the overall volume by up to 50%, this new package size is an ideal choice in space constrained applications over previous IDC connectors. In addition, an expanded size range is available starting from a 1 position up to 4 positions in each wire gauge. The entire range provides new packaging solutions in industrial, medical and transportation applications such as smart metering, LED lighting, industrial controls and portable monitoring and measurement devices.

APPLICATIONS

- Connecting discrete wires and components to a PCB
- Bringing power and signals onto a PCB
- Daisy chaining or interconnecting PCB's together
- Application Notes: Refer to 201-01-216

FEATURES AND BENEFITS

- Redundant and fatigue resistant phosphor bronze material provides a gas tight, cold welded connection to the wire
- IDC connectors can be potted or over molded to encapsulate electronic modules and provide environmental protection
- The 1p version is available in industry standard colors to match individual wires for error free wire termination

ELECTRICAL

- Current Rating: 22AWG: 7 amps
24AWG: 6 amps
26AWG: 5 amps
28AWG: 4 amps
30AWG: 3 amps
- Voltage Rating: 1p: 600V
2p-4p: 100V
- Durability: 1 Cycle

ENVIRONMENTAL

- Operating Temperature: -40°C to +125°C

MECHANICAL

- Insulator Material: Glass-Filled Nylon 46; UL94V0
- Contact Material: Phosphor Bronze
- Plating: Lead-Free Tin Over Nickel

HOW TO ORDER

00
Prefix
Wire to Board
Connector

9176
Series

00X
Number
of Ways
001 = 1
002 = 2
003 = 3
004 = 4

8XX
Wire Gauge Size

Code	Accepted Wire Gauge	Maximum Wire Isulation Diameter	UL Approved
853	22AWG Solid and Stranded	1.40	Approved
863	24AWG Solid and Stranded	1.40	Approved
873	26AWG Solid and Stranded	1.40	Approved
883	28AWG Solid and Stranded	0.80 to 1.40	Approved
884	28AWG Solid and Stranded	0.80	Approved
893	30AWG Solid and Stranded	0.80 to 1.40	Approved
894	30AWG Solid and Stranded	0.80	Approved

X
Insulator Color
9 = White Standard
Solid Colors (1p only)
2 = Brown
3 = Blue
4 = Yellow
5 = Red
6 = Green
7 = Orange
8 = Black

06
Plating Option
06 = Pure Tin
All Over Nickel

LOW PROFILE IDC 22-30 AWG: 9176-800

1 Position

00-9176-001-8XX-X06

1 WAY

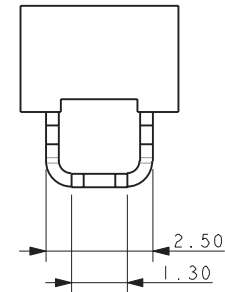
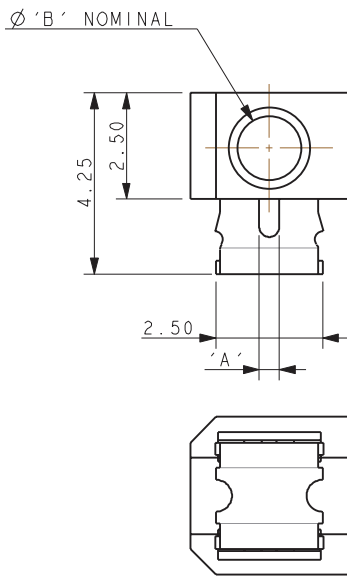
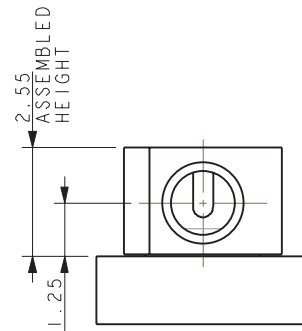
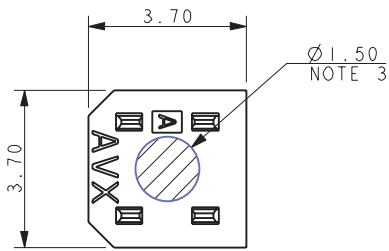

NOTES:

- 1 WAY CONNECTOR FOR IDC WIRE TO BOARD CONNECTOR.
- CONTACT/CAP TO MATCH 22AWG TO 26AWG STRANDED AND SOLID WIRE, MAXIMUM INSULATOR 1.40 DIAMETER
- FLAT FACE ON TOP OF CAP TO AID PICK AND PLACE ASSEMBLY.
- FOR FULL PRODUCT SPECIFICATION REFER TO KYOCERA AVX SPEC 201-01-215.
- ASSEMBLY PROCEDURE, REFER TO APPLICATION NOTES 201-01-216.
- GENERAL TOLERANCE ± 0.20 UNLESS STATED.
- PACKED IN TAPE AND REEL, QUANTITY PER REEL 1700.
- CONNECTOR OUTLINE.
- CONTACT MATERIAL: TIN PLATED COPPER ALLOY.
- INSULATOR MATERIAL: HIGH TEMPERATURE NYLON, GLASS FILLED. UL94 V-0, COLOR REFER TO PAGE 54.
- UL REFERENCE E90723 (US AND CANADA).

PART NUMBER See page 54	WIRE GAUGE	B	A
00-9176-001-853-X06	22AWG Solid and Stranded	1.50	0.47
00-9176-001-863-X06	24AWG Solid and Stranded	1.50	0.37
00-9176-001-873-X06	26AWG Solid and Stranded	1.50	0.28
00-9176-001-883-X06	28AWG Solid and Stranded	1.50	0.20
00-9176-001-884-X06	28AWG Solid and Stranded	0.90	0.20
00-9176-001-893-X06	30AWG Solid and Stranded	1.50	0.20
00-9176-001-894-X06	30AWG Solid and Stranded	0.90	0.20

SUGGESTED PCB LAYOUT

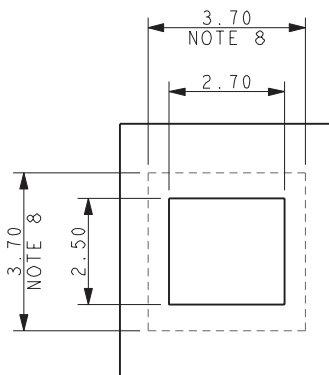

PACKING DETAILS

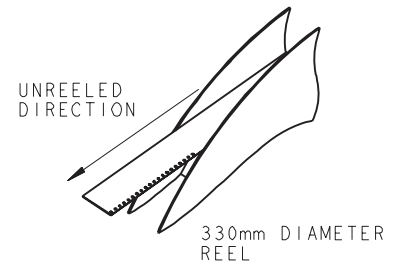
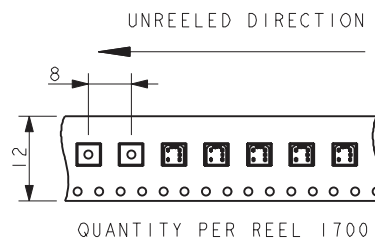

LOW PROFILE IDC 22-30 AWG: 9176-800

2 Position

00-9176-001-8XX-X06

2 WAY

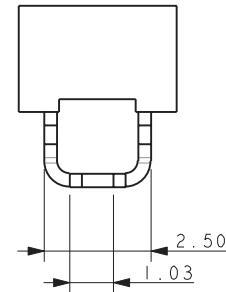
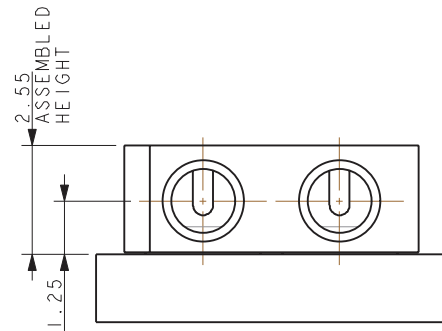
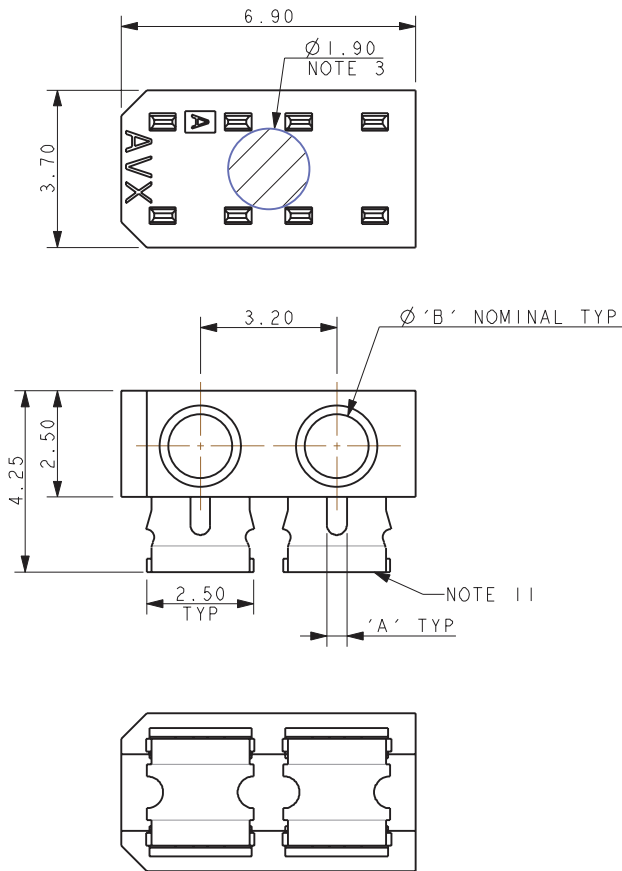

NOTES:

- 2 WAY CONNECTOR FOR IDC WIRE TO BOARD CONNECTOR.
- CONTACT/CAP TO MATCH 22AWG TO 26AWG STRANDED AND SOLID WIRE, MAXIMUM INSULATOR 1.40 DIAMETER
- FLAT FACE ON TOP OF CAP TO AID PICK AND PLACE ASSEMBLY.
- FOR FULL PRODUCT SPECIFICATION REFER TO KYOCERA AVX SPEC 201-01-215.
- ASSEMBLY PROCEDURE, REFER TO APPLICATION NOTES 201-01-216.
- GENERAL TOLERANCE ± 0.20 UNLESS STATED.
- PACKED IN TAPE AND REEL, QUANTITY PER REEL 1700.
- CONNECTOR OUTLINE.
- CONTACT MATERIAL: TIN PLATED COPPER ALLOY.
- INSULATOR MATERIAL: HIGH TEMPERATURE NYLON, GLASS FILLED. UL94 V-0, COLOR REFER TO PAGE 54.
- UL REFERENCE E90723 (US AND CANADA).

PART NUMBER See page 54	WIRE GAUGE	B	A
00-9176-002-853-X06	22AWG Solid and Stranded	1.50	0.47
00-9176-002-863-X06	24AWG Solid and Stranded	1.50	0.37
00-9176-002-873-X06	26AWG Solid and Stranded	1.50	0.28
00-9176-002-883-X06	28AWG Solid and Stranded	1.50	0.20
00-9176-002-884-X06	28AWG Solid and Stranded	0.90	0.20
00-9176-002-893-X06	30AWG Solid and Stranded	1.50	0.20
00-9176-002-894-X06	30AWG Solid and Stranded	0.90	0.20

SUGGESTED PCB LAYOUT

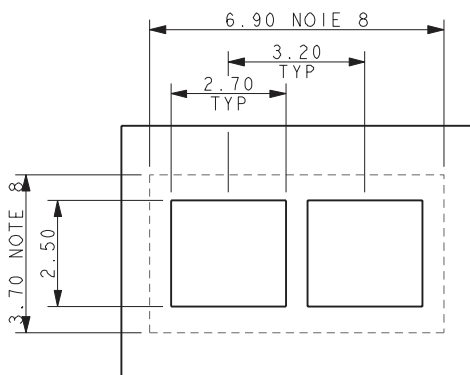

PACKING DETAILS

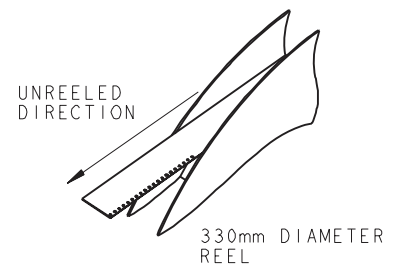
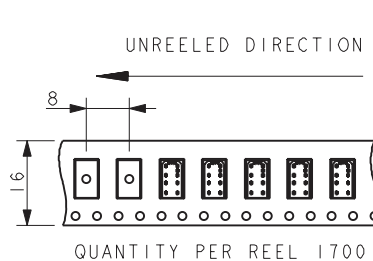

LOW PROFILE IDC 22-30 AWG: 9176-800

3 Position

00-9176-001-8XX-X06

3 WAY

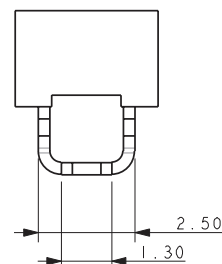
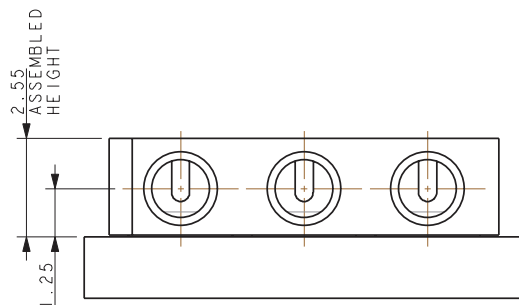
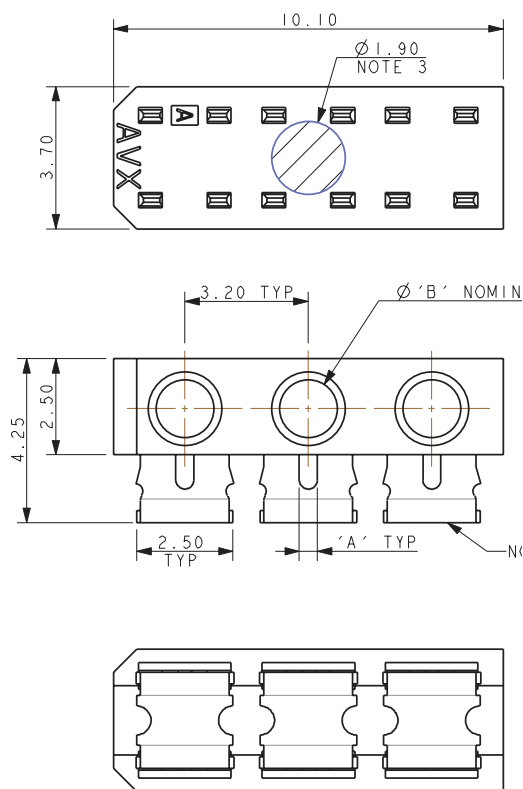

NOTES:

1. 3 WAY CONNECTOR FOR IDC WIRE TO BOARD CONNECTOR.
2. CONTACT/CAP TO MATCH 22AWG TO 26AWG STRANDED AND SOLID WIRE, MAXIMUM INSULATOR 1.40 DIAMETER
3. FLAT FACE ON TOP OF CAP TO AID PICK AND PLACE ASSEMBLY.
4. FOR FULL PRODUCT SPECIFICATION REFER TO KYOCERA AVX SPEC 201-01-215.
5. ASSEMBLY PROCEDURE, REFER TO APPLICATION NOTES 201-01-216.
6. GENERAL TOLERANCE ± 0.20 UNLESS STATED.
7. PACKED IN TAPE AND REEL, QUANTITY PER REEL 1700.
8. CONNECTOR OUTLINE.
9. CONTACT MATERIAL: TIN PLATED COPPER ALLOY.
10. INSULATOR MATERIAL: HIGH TEMPERATURE NYLON, GLASS FILLED. UL94 V-0, COLOR REFER TO PAGE 54.
11. UL REFERENCE E90723 (US AND CANADA).

PART NUMBER See page 54	WIRE GAUGE	B	A
00-9176-003-853-X06	22AWG Solid and Stranded	1.50	0.47
00-9176-003-863-X06	24AWG Solid and Stranded	1.50	0.37
00-9176-003-873-X06	26AWG Solid and Stranded	1.50	0.28
00-9176-003-883-X06	28AWG Solid and Stranded	1.50	0.20
00-9176-003-884-X06	28AWG Solid and Stranded	0.90	0.20
00-9176-003-893-X06	30AWG Solid and Stranded	1.50	0.20
00-9176-003-894-X06	30AWG Solid and Stranded	0.90	0.20

SUGGESTED PCB LAYOUT

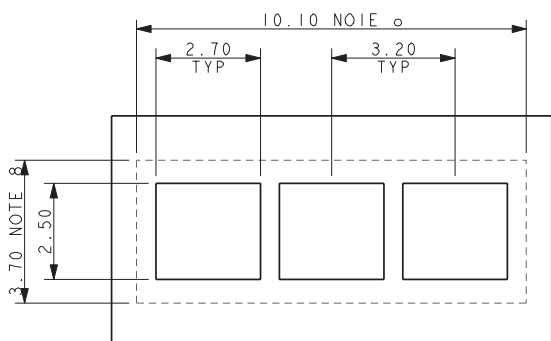

PACKING DETAILS

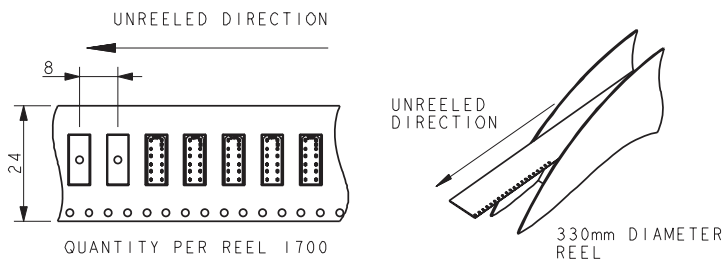

LOW PROFILE IDC 22-30 AWG: 9176-800

4 Position

00-9176-001-8X3-X06

4 WAY

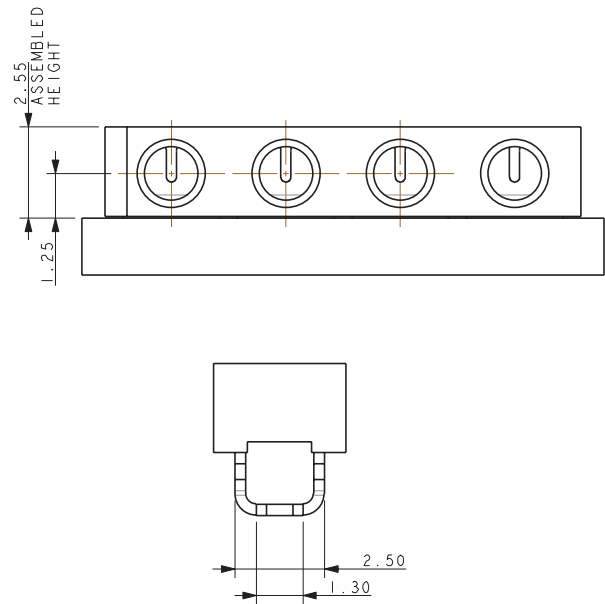
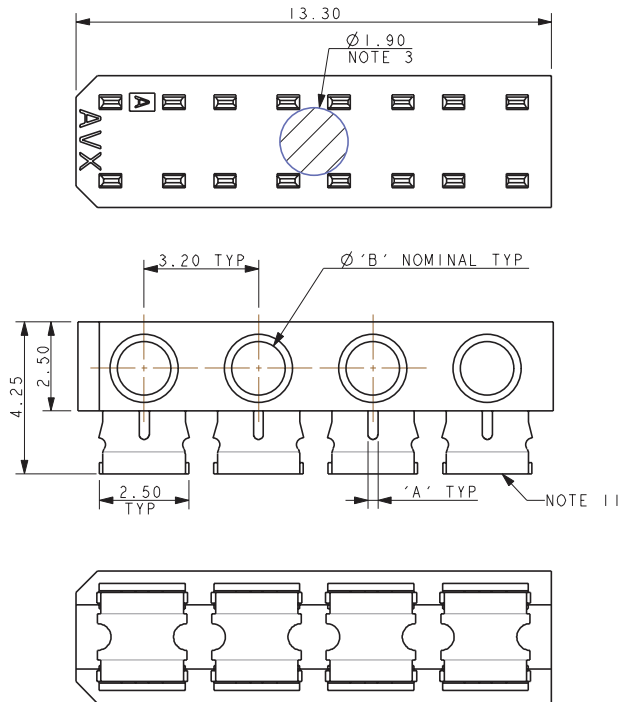

PART NUMBER See page 54	WIRE GAUGE	B	A
00-9176-004-853-X06	22AWG Solid and Stranded	1.50	0.47
00-9176-004-863-X06	24AWG Solid and Stranded	1.50	0.37
00-9176-004-873-X06	26AWG Solid and Stranded	1.50	0.28
00-9176-004-883-X06	28AWG Solid and Stranded	1.50	0.20
00-9176-004-884-X06	28AWG Solid and Stranded	0.90	0.20
00-9176-004-893-X06	30AWG Solid and Stranded	1.50	0.20
00-9176-004-894-X06	30AWG Solid and Stranded	0.90	0.20

NOTES:

- 4 WAY CONNECTOR FOR IDC WIRE TO BOARD CONNECTOR.
- CONTACT/CAP TO MATCH 22AWG TO 26AWG STRANDED AND SOLID WIRE, MAXIMUM INSULATOR 1.40 DIAMETER
- FLAT FACE ON TOP OF CAP TO AID PICK AND PLACE ASSEMBLY.
- FOR FULL PRODUCT SPECIFICATION REFER TO KYOCERA AVX SPEC 201-01-215.
- ASSEMBLY PROCEDURE, REFER TO APPLICATION NOTES 201-01-216.
- GENERAL TOLERANCE ± 0.20 UNLESS STATED.
- PACKED IN TAPE AND REEL, QUANTITY PER REEL 1700.
- CONNECTOR OUTLINE.
- CONTACT MATERIAL: TIN PLATED COPPER ALLOY.
- INSULATOR MATERIAL: HIGH TEMPERATURE NYLON, GLASS FILLED. UL94 V-0, COLOR REFER TO PAGE 54.
- UL REFERENCE E90723 (US AND CANADA).

SUGGESTED PCB LAYOUT

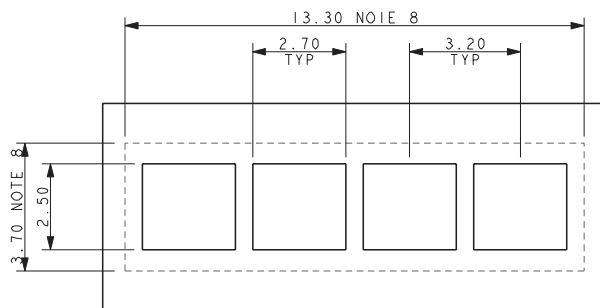

PACKING DETAILS

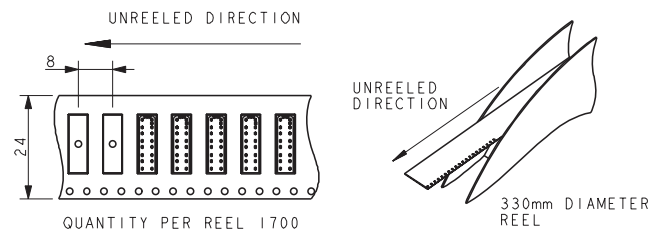

LOW PROFILE IDC 22-30 AWG: 9176-800

Conector Details

CONNECTOR DETAILS

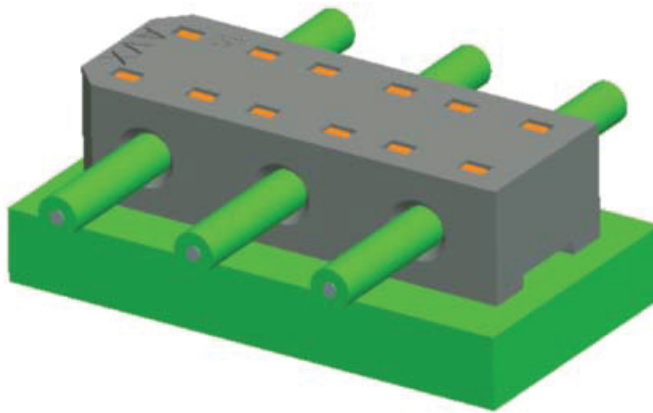

00-9176-00X-8X4-X06

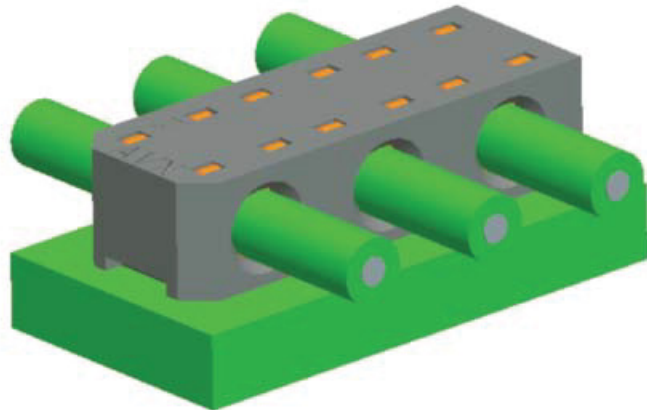

00-9176-00X-8X3-X06

STANDARD 14-20 AWG: 00-9177

General Information

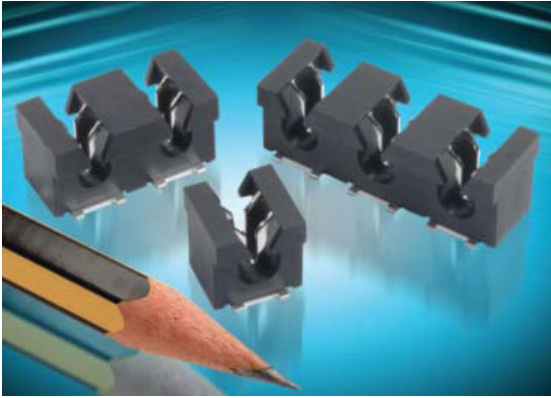

The 917X series of surface mount Insulation Displacement Connectors (IDC) were developed to meet the harsh automotive and industrial market applications for connecting individual wires directly to a PCB ranging from 14 AWG to 28 AWG. This industry proven contact system has been tested to automotive levels of shock, vibration, and temperature cycling to prove their reliability and robustness. The simplicity of inserting a wire into the connector with a small tool allows a wide range of devices to be connected to the PCB without soldering. In SSL applications specifically, these connectors are used to bring power and signal onto the PCB or are used to daisy chain multiple boards together in a long string. While the IDC contact provides a gas-tight connection to conductor of the wire, the housing has been designed to grab the insulation of the wire to provide a positive strain relief even in the harshest conditions. In case of repair, the wires can be removed and replaced up to three times.

The 9177 series accepts 14 AWG to 20 AWG wires with an insulation diameter ranging from 2.75mm to 4.25mm. These dual contact connectors support a 15 amp current rating with two large SMT solder tails per wire to provide maximum stability on the PCB. Available in 1p-3p configuration, these connectors can be end stackable for higher pin counts.

APPLICATIONS

- Connecting discrete wire components directly to the PCB
- Bringing power and signals onto a PCB
- Daisy chaining PCB's together to create a continuous string of boards
- Application Notes: refer to 201-01-124

FEATURES AND BENEFITS

- IDC contact provides a gas-tight connection to the PCB for long term reliability
- Connector housing captures the wire insulation for positive strain relief
- Tested to automotive levels on shock, vibration and temperature cycling for reliability
- Low and high volume assembly tools to match production volumes
- Reduced total applied cost versus solder or crimp processes
- High temperature insulator capable to 260°C reflow soldering processes

ELECTRICAL

- Current Rating: 15 Amp / Contact
- Voltage Rating: 600 VAC

ENVIRONMENTAL

- Operating Temperature: -40°C to +125°C

MECHANICAL

- Insulator Material: Nylon 46: UL94V0
- Contact Material: Phosphor Bronze
- Plating: Tin over Nickel
- Durability: 3 Cycles

HOW TO ORDER

00 Prefix	9177 Series	00X Number of Ways	0XX Wire Gauge Size	X Color/Approval	06 Plating Option																																										
		<table border="1"> <thead> <tr> <th>Code</th> <th>No of Ways</th> <th>Details</th> </tr> </thead> <tbody> <tr> <td>001</td> <td>1</td> <td>Page 62</td> </tr> <tr> <td>002</td> <td>2</td> <td>Page 63</td> </tr> <tr> <td>003</td> <td>3</td> <td>Page 64</td> </tr> </tbody> </table>	Code	No of Ways	Details	001	1	Page 62	002	2	Page 63	003	3	Page 64	<table border="1"> <thead> <tr> <th>Code</th> <th>Accepted Wire Gauge</th> <th>Wire Insulation</th> </tr> </thead> <tbody> <tr> <td>001</td> <td>14 AWG Solid or Stranded</td> <td>Ø 4.25</td> </tr> <tr> <td>012</td> <td>16 AWG Solid or Stranded</td> <td>Ø 3.50</td> </tr> <tr> <td>022</td> <td>18 AWG Solid or Stranded</td> <td>Ø 3.50</td> </tr> <tr> <td>033</td> <td>20 AWG Solid or Stranded</td> <td>Ø 2.75</td> </tr> </tbody> </table>	Code	Accepted Wire Gauge	Wire Insulation	001	14 AWG Solid or Stranded	Ø 4.25	012	16 AWG Solid or Stranded	Ø 3.50	022	18 AWG Solid or Stranded	Ø 3.50	033	20 AWG Solid or Stranded	Ø 2.75	<table border="1"> <thead> <tr> <th>Code</th> <th>Color</th> <th>Approval</th> </tr> </thead> <tbody> <tr> <td>0</td> <td>Black</td> <td>Special Order - NON-UL</td> </tr> <tr> <td>1</td> <td>White</td> <td>Special Order - NON-UL</td> </tr> <tr> <td>8</td> <td>Black</td> <td>Special Order - UL APPROVED</td> </tr> <tr> <td>9</td> <td>White</td> <td>Standard - UL APPROVED</td> </tr> </tbody> </table>	Code	Color	Approval	0	Black	Special Order - NON-UL	1	White	Special Order - NON-UL	8	Black	Special Order - UL APPROVED	9	White	Standard - UL APPROVED	06 = Pure Tin all Over
Code	No of Ways	Details																																													
001	1	Page 62																																													
002	2	Page 63																																													
003	3	Page 64																																													
Code	Accepted Wire Gauge	Wire Insulation																																													
001	14 AWG Solid or Stranded	Ø 4.25																																													
012	16 AWG Solid or Stranded	Ø 3.50																																													
022	18 AWG Solid or Stranded	Ø 3.50																																													
033	20 AWG Solid or Stranded	Ø 2.75																																													
Code	Color	Approval																																													
0	Black	Special Order - NON-UL																																													
1	White	Special Order - NON-UL																																													
8	Black	Special Order - UL APPROVED																																													
9	White	Standard - UL APPROVED																																													



HOW TO ORDER – CAP OPTIONS – THROUGH WIRE

00 Prefix 60 = Cap	9177 Series	00X Number of Ways	0XX Wire Gauge Size	X00 Insulator Color																														
		<table border="1"> <thead> <tr> <th>Code</th> <th>No of Ways</th> </tr> </thead> <tbody> <tr> <td>001</td> <td>1</td> </tr> <tr> <td>002</td> <td>2</td> </tr> <tr> <td>003</td> <td>3</td> </tr> </tbody> </table>	Code	No of Ways	001	1	002	2	003	3	<table border="1"> <thead> <tr> <th>Code</th> <th>Wire Insulator Diameter (Note 3)</th> <th>A</th> <th>B</th> </tr> </thead> <tbody> <tr> <td>027</td> <td>2.10mm - 2.75mm</td> <td>Ø2.75</td> <td>2.00</td> </tr> <tr> <td>035</td> <td>2.75mm - 3.50mm</td> <td>Ø3.50</td> <td>2.65</td> </tr> <tr> <td>042</td> <td>3.50mm - 4.25mm</td> <td>Ø4.25</td> <td>3.40</td> </tr> </tbody> </table>	Code	Wire Insulator Diameter (Note 3)	A	B	027	2.10mm - 2.75mm	Ø2.75	2.00	035	2.75mm - 3.50mm	Ø3.50	2.65	042	3.50mm - 4.25mm	Ø4.25	3.40	<table border="1"> <thead> <tr> <th>Code</th> <th>Color</th> </tr> </thead> <tbody> <tr> <td>000</td> <td>Black</td> </tr> <tr> <td>100</td> <td>White</td> </tr> </tbody> </table>	Code	Color	000	Black	100	White
Code	No of Ways																																	
001	1																																	
002	2																																	
003	3																																	
Code	Wire Insulator Diameter (Note 3)	A	B																															
027	2.10mm - 2.75mm	Ø2.75	2.00																															
035	2.75mm - 3.50mm	Ø3.50	2.65																															
042	3.50mm - 4.25mm	Ø4.25	3.40																															
Code	Color																																	
000	Black																																	
100	White																																	

HOW TO ORDER – CAP OPTIONS – WIRE STOP

60 Prefix 60 = Cap	9177 Series	00X Number of Ways	0XX Wire Gauge Size	X00 Insulator Color																														
		<table border="1"> <thead> <tr> <th>Code</th> <th>No of Ways</th> </tr> </thead> <tbody> <tr> <td>001</td> <td>1</td> </tr> <tr> <td>002</td> <td>2</td> </tr> <tr> <td>003</td> <td>3</td> </tr> </tbody> </table>	Code	No of Ways	001	1	002	2	003	3	<table border="1"> <thead> <tr> <th>Code</th> <th>Wire Insulator Diameter (Note 3)</th> <th>A</th> <th>B</th> </tr> </thead> <tbody> <tr> <td>027</td> <td>2.10mm - 2.75mm</td> <td>Ø2.75</td> <td>2.00</td> </tr> <tr> <td>035</td> <td>2.75mm - 3.50mm</td> <td>Ø3.50</td> <td>2.65</td> </tr> <tr> <td>042</td> <td>3.50mm - 4.25mm</td> <td>Ø4.25</td> <td>3.40</td> </tr> </tbody> </table>	Code	Wire Insulator Diameter (Note 3)	A	B	027	2.10mm - 2.75mm	Ø2.75	2.00	035	2.75mm - 3.50mm	Ø3.50	2.65	042	3.50mm - 4.25mm	Ø4.25	3.40	<table border="1"> <thead> <tr> <th>Code</th> <th>Color</th> </tr> </thead> <tbody> <tr> <td>099</td> <td>Black</td> </tr> <tr> <td>199</td> <td>White</td> </tr> </tbody> </table>	Code	Color	099	Black	199	White
Code	No of Ways																																	
001	1																																	
002	2																																	
003	3																																	
Code	Wire Insulator Diameter (Note 3)	A	B																															
027	2.10mm - 2.75mm	Ø2.75	2.00																															
035	2.75mm - 3.50mm	Ø3.50	2.65																															
042	3.50mm - 4.25mm	Ø4.25	3.40																															
Code	Color																																	
099	Black																																	
199	White																																	

Certification:
UL File # E320991,
check UL conditions of use for
specific ratings and details

STANDARD 14-20 AWG: 00-9177

General Information

CONNECTOR/TOOLING PART NUMBER MATRIX

AWG	Wire Insulation	SERIES 9177 IDC			HAND INSERTION TOOLING*		ACCESSORY CAPS	
		Positions	Color	Part Number	Plastic (low volume)	Metal (high volume)	Through Wire	Wire Stop
14	Ø 4.25	1p	White	009177001001106	069177701601001	069177701701001	609177001042100	609177001042199
14	Ø 4.25	1p	Black	009177001001006	069177701601001	069177701701001	609177001042000	609177001042099
14	Ø 4.25	2p	White	009177002001106	069177701601002	069177701701002	609177002042100	609177002042199
14	Ø 4.25	2p	Black	009177002001006	069177701601002	069177701701002	609177002042000	609177002042099
14	Ø 4.25	3p	White	009177003001106	069177701601003	069177701701003	609177003042100	609177003042199
14	Ø 4.25	3p	Black	009177003001006	069177701601003	069177701701003	609177003042000	609177003042099
16	Ø 3.50	1p	White	009177001012106	069177701602001	069177701702001	609177001035100	609177001035199
16	Ø 3.50	1p	Black	009177001012006	069177701602001	069177701702001	609177001035000	609177001035099
16	Ø 3.50	2p	White	009177002012106	069177701602002	069177701702002	609177002035100	609177002035199
16	Ø 3.50	2p	Black	009177002012006	069177701602002	069177701702002	609177002035000	609177002035099
16	Ø 3.50	3p	White	009177003012106	069177701602003	069177701702003	609177003035100	609177003035199
16	Ø 3.50	3p	Black	009177003012006	069177701602003	069177701702003	609177003035000	609177003035099
18	Ø 3.50	1p	White	009177001022106	069177701602001	069177701702001	609177001035100	609177001035199
18	Ø 3.50	1p	Black	009177001022006	069177701602001	069177701702001	609177001035000	609177001035099
18	Ø 3.50	2p	White	009177002022106	069177701602002	069177701702002	609177002035100	609177002035199
18	Ø 3.50	2p	Black	009177002022006	069177701602002	069177701702002	609177002035000	609177002035099
18	Ø 3.50	3p	White	009177003022106	069177701602003	069177701702003	609177003035100	609177003035199
18	Ø 3.50	3p	Black	009177003022006	069177701602003	069177701702003	609177003035000	609177003035099
20	Ø 2.75	1p	White	009177001033106	069177701603001	069177701703001	609177001027100	609177001027199
20	Ø 2.75	1p	Black	009177001033006	069177701603001	069177701703001	609177001027000	609177001027099
20	Ø 2.75	2p	White	009177002033106	069177701603002	069177701703002	609177002027100	609177002027199
20	Ø 2.75	2p	Black	009177002033006	069177701603002	069177701703002	609177002027000	609177002027099
20	Ø 2.75	3p	White	009177003033106	069177701603003	069177701703003	609177003027100	609177003027199
20	Ø 2.75	3p	Black	009177003033006	069177701603003	069177701703003	609177003027000	609177003027099

* Insertion Tooling - Requires Hand Press with Flat Rock Plates; Consult Application Notes 201-01-124

STANDARD 14-20 AWG: 00-9177

1 Position

14-20 AWG 1 WAY IDC CONNECTOR



Pick and place area 2.375 x 9.00mm MIN

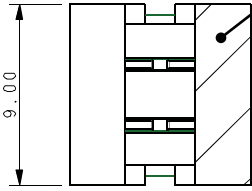

NOTES:

1. CONNECTOR FOR IDC WIRE TO BOARD CONNECTION.
2. CONTACT MATERIAL: PHOSPHOR BRONZE. INSULATION MATERIAL: HIGH TEMP NYLON 46, COLOUR REFER TO SHEET 1.
3. CONNECTOR DESIGNED TO ACCEPT BETWEEN 14AWG AND 20AWG SOLID AND STRANDED WIRE.
4. ALL DIMENSIONS ± 0.20 UNLESS TOLERANCED
5. FOR FULL PRODUCT SPECIFICATION ON STANDARD CONNECTORS REFER TO ELCO SPEC 201-01-109, UL COMPONENTS REFER TO ELCO SPEC 201-01-109UL.
6. APPLICATION NOTES 201-01-124
7. FOR UL PRODUCT CODES UL REFERENCE E320991.
8. FOR PCB SPACE RESTRICTED BY ASSEMBLY TOOLING REFER TO SHEET 6

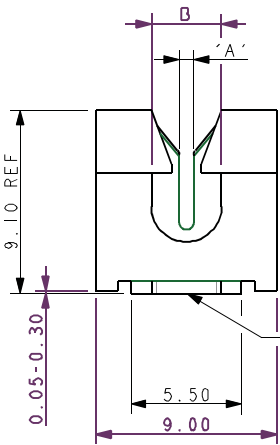

ALL TAILS TO BE WITHIN 0.10mm COPLANARITY.

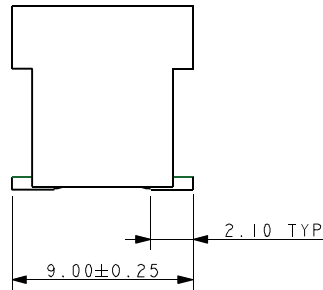

Code	Accepted Wire Gauge	A	Wire Insulation	B
001	14 AWG Solid or Stranded	1.10	Ø4.25 max	4.25
012	16 AWG Solid or Stranded	0.82	Ø3.50 max	3.50
022	18 AWG Solid or Stranded	0.72	Ø3.50 max	3.50
033	20 AWG Solid or Stranded	0.60	Ø2.75 max	2.75

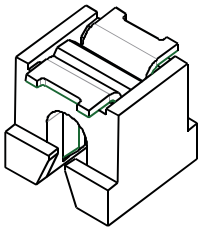
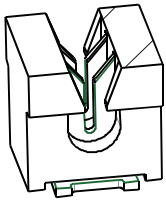

SMT PCB LAYOUT PURE TIN PADS

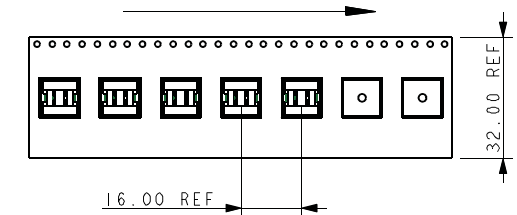
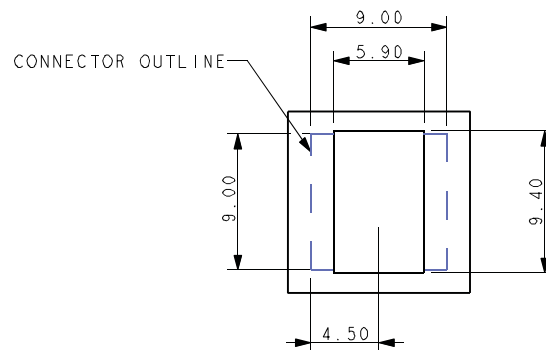

PACKING DETAILS

REEL QTY	400
LEADER	500MM
TRAILER	400MM
REEL/BOX	4
PACK QTY	1600

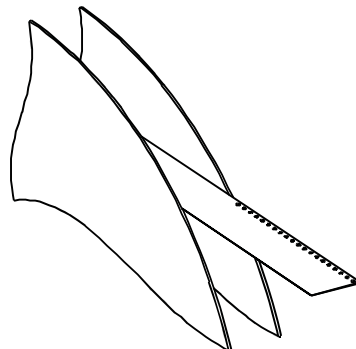

STANDARD 14-20 AWG: 00-9177

2 Position

14-20 AWG 2 WAY IDC CONNECTOR

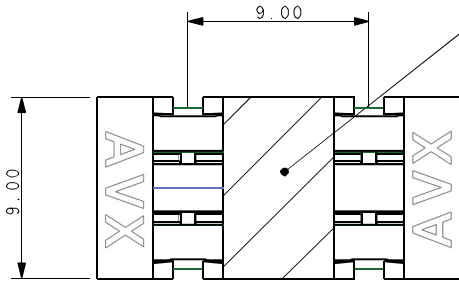

PICK UP AREA 4.75 x 9.00mm MIN

NOTES:

1. CONNECTOR FOR IDC WIRE TO BOARD CONNECTION.
2. CONTACT MATERIAL: PHOSPHOR BRONZE. INSULATION MATERIAL: HIGH TEMP NYLON 46, COLOUR REFER TO SHEET 1.
3. CONNECTOR DESIGN TO ACCEPT BETWEEN 14AWG AND 20AWG SOLID AND STRANDED WIRE.
4. ALL DIMENSIONS ± 0.20 UNLESS TOLLERANCED.
5. FOR FULL PRODUCT SPECIFICATION ON STANDARD CONNECTORS REFER TO ELCO SPEC 201-01-109, UL COMPONENTS REFER TO ELCO SPEC 201-01-109UL.
6. APPLICATION NTOES 201-01-124.
7. FOR UL PRODUCT CODES UL REFERENCE E320991
8. FOR PCB SPACE RESTRICTED BY ASSEMBLY TOOLING REFER TO SHEET 6

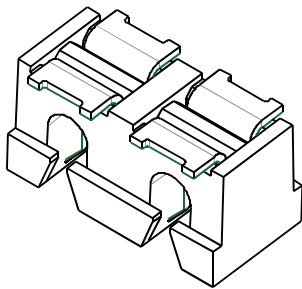
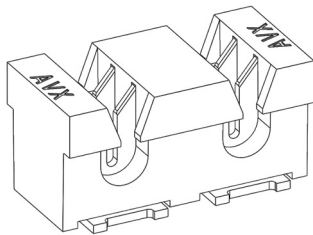
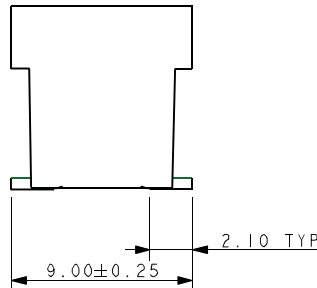
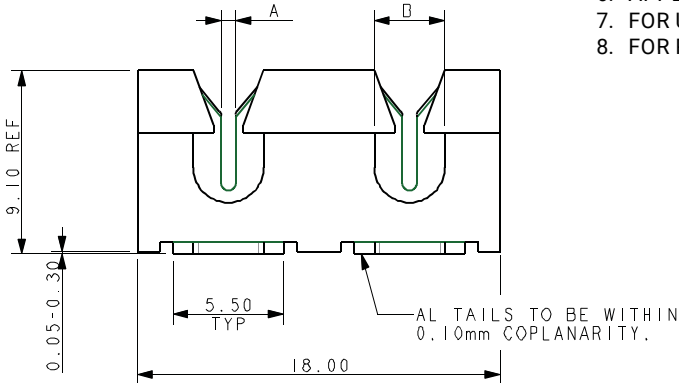

Code	Accepted Wire Gauge	A	Wire Insulation	B
001	14 AWG Solid or Stranded	1.10	Ø4.25 max	4.25
012	16 AWG Solid or Stranded	0.82	Ø3.50 max	3.50
022	18 AWG Solid or Stranded	0.72	Ø3.50 max	3.50
033	20 AWG Solid or Stranded	0.60	Ø2.75 max	2.75

SMT PCB LAYOUT PURE TIN PADS

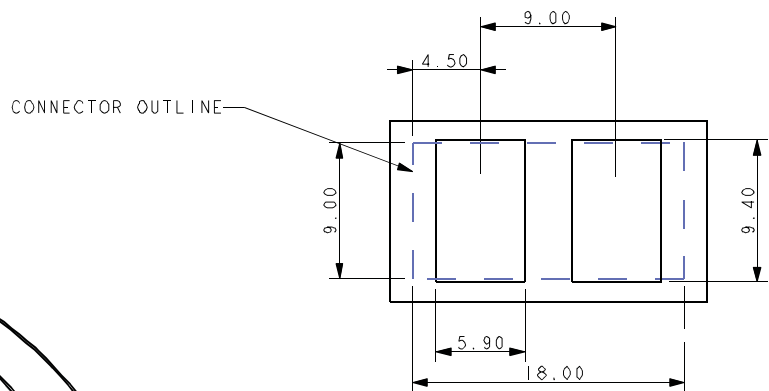

PACKING DETAILS

REEL QTY	400
LEADER	500mm
TRAILER	400mm
REEL DIAMETER	330mm

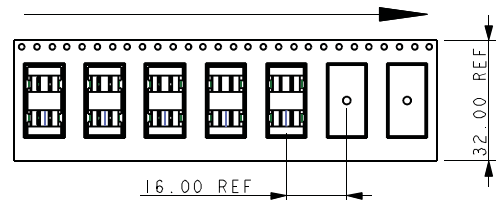
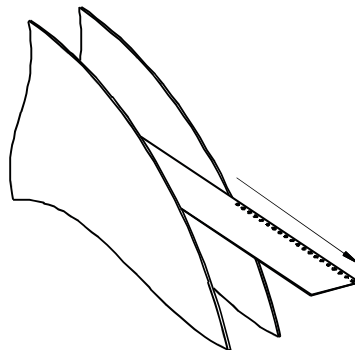

STANDARD 14-20 AWG: 00-9177

3 Position

14-20 AWG 3 WAY IDC CONNECTOR

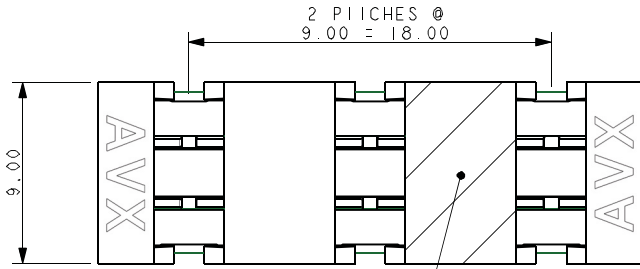

PICK UP AREA 4.75 x 9.00mm MIN

NOTES:

- CONNECTOR FOR IDC WIRE TO BOARD CONNECTION.
- CONTACT MATERIAL: PHOSPHOR BRONZE.
INSULATION MATERIAL: HIGH TEMP NYLON 46, COLOUR REFER TO SHEET 1
- CONNECTOR DESIGNED TO ACCEPT BETWEEN 14AWG AND 20AWG SOLID AND STRANDED WIRE.
- ALL DIMENSIONS ± 0.20 UNLESS TOLERANCED.
- FOR FULL PRODUCT SPECIFICATION ON STANDARD CONNECTORS REFER TO ELCO SPEC 201-01-109, UL COMPONENTS REFER TO ELCO SPEC 201-01-109UL.
- APPLICATION NOTES 201-01-124.
- FOR UL PRODUCT CODES UL REFERENCE E320991.
- FOR PCO SPACE RESTRICTED BY ASSEMBLY TOOLING REFER TO SHEET 6

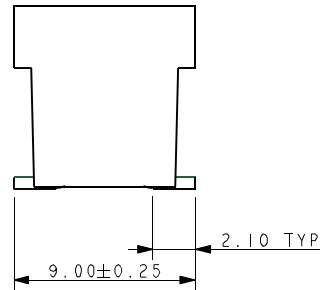
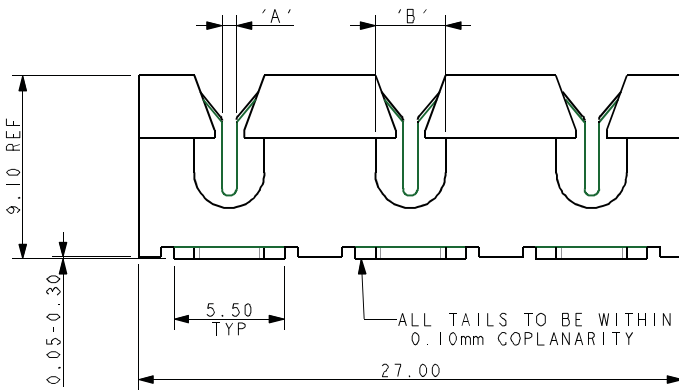

Code	Accepted Wire Gauge	A	Wire Insulation	B
001	14 AWG Solid or Stranded	1.10	Ø4.25 max	4.25
012	16 AWG Solid or Stranded	0.82	Ø3.50 max	3.50
022	18 AWG Solid or Stranded	0.72	Ø3.50 max	3.50
033	20 AWG Solid or Stranded	0.60	Ø2.75 max	2.75

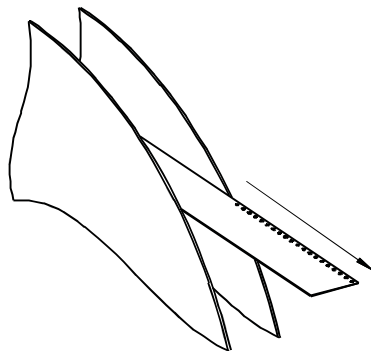
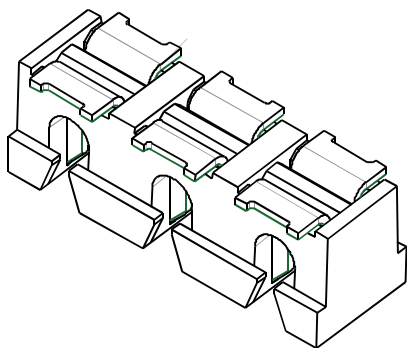
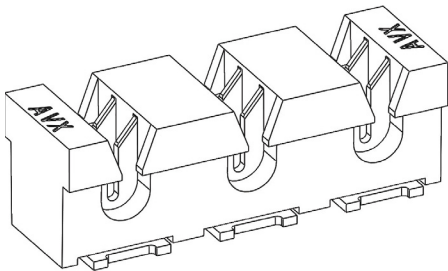

SMT PCB LAYOUT PURE TIN PADS

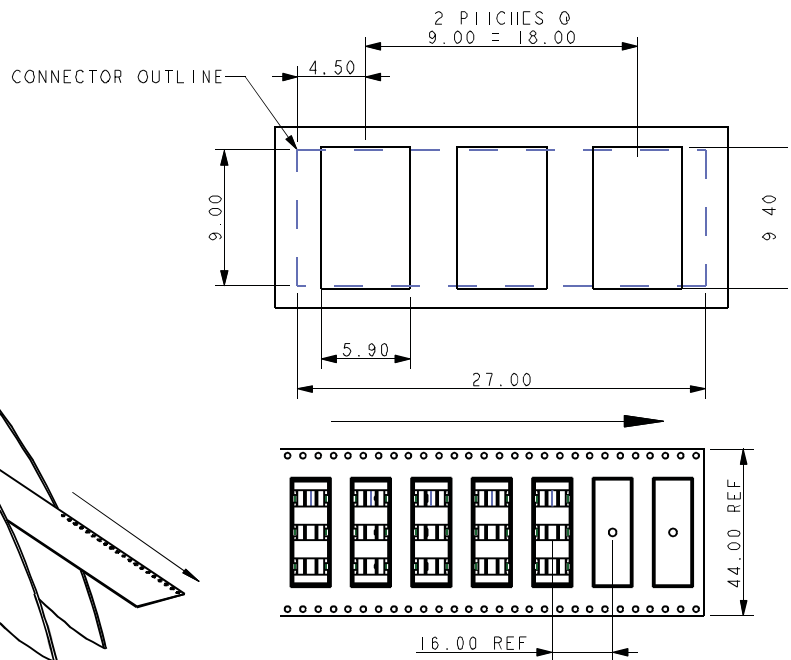

PACKING DETAILS

REEL QTY	400
LEADER	500mm
TRAILER	400mm
REEL DIAMETER	330mm

STANDARD 14-20 AWG: 00-9177

Accessory Cap - Through Wire

ACCESSORY CAP – THROUGH WIRE



HOW TO ORDER

60

9177

00X

0XX

X00

Code	No of Ways
001	1
002	2
003	3

Code	Wire Insulation Diameter (Note 3)	"A"	"B"
027	2.10mm - 2.75mm	ø 2.75	2.00
035	2.75mm - 3.50mm	ø 3.50	2.65
042	3.50mm - 4.25mm	ø 4.25	3.40

Code	COLOUR
000	Black
100	White

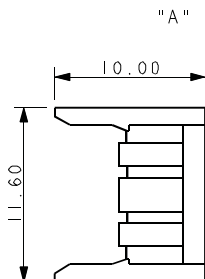
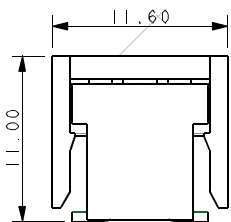

"A" REFER TO TABLE

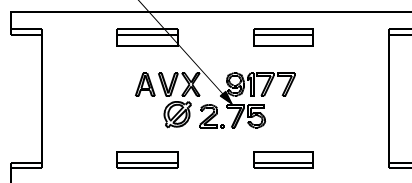

ASSEMBLED DIMENSIONS

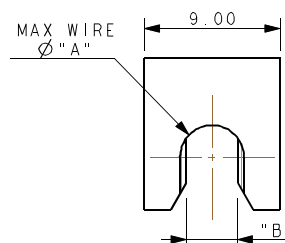
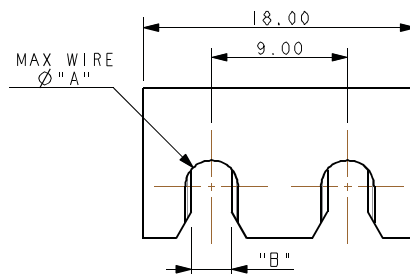
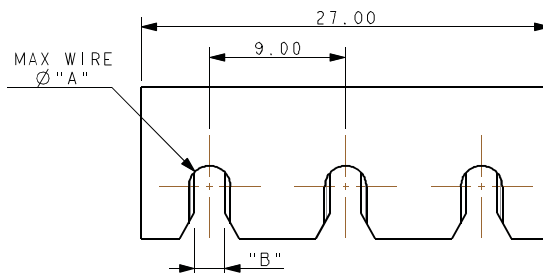
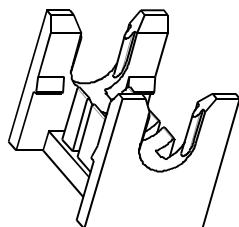
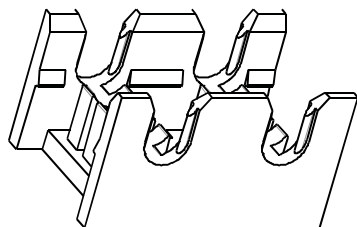
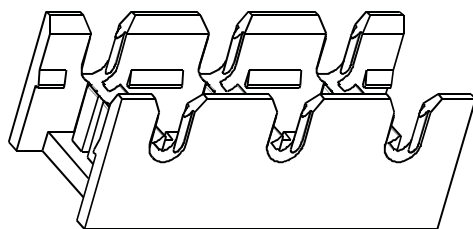

NOTES:

- CAP FOR 9177 IDC WIRE TO BOARD CONNECTOR.
- THROUGH WIRE CAP CAN BE USED AT ANY POSITION ALONG WIRE.
- REFERS TO CAP, FOR WIRE MATCH TO CONNECTOR REFER TO TABLE ON SHEET
- MATERIAL: GLASS FILLED NYLON 46, FOR COLOUR REFER TO TABLE
- CAPS DESIGNED TO ACCOODATE INSULATION DIAMETERS REFER TO TABLE.
- GENERAL TOLERANCE $\pm 0.20\text{mm}$.
- PACKED IN BAGS, 400 PIECES PER BAG
- APPLICATION NOTES REFER TO ELCO SPECIFICATION 201-01-124

STANDARD 14-20 AWG: 00-9177

Accessory Cap - Wire Stop

ACCESSORY CAP – WIRE STOP

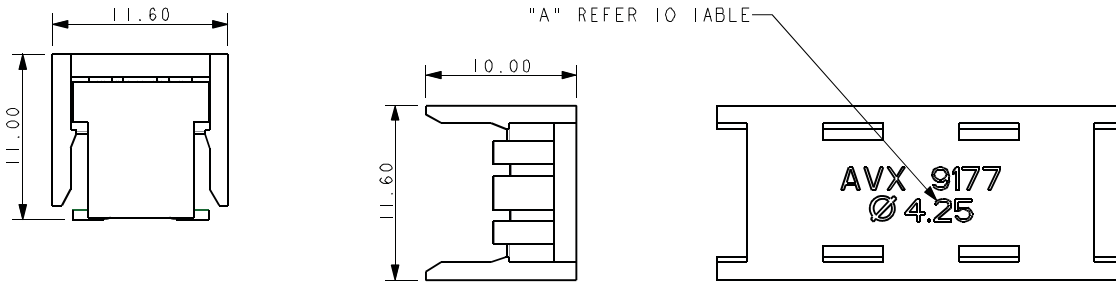

ASSEMBLED DIMENSIONS

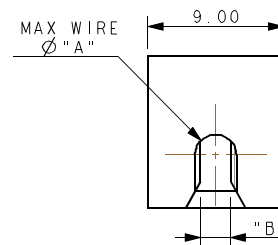
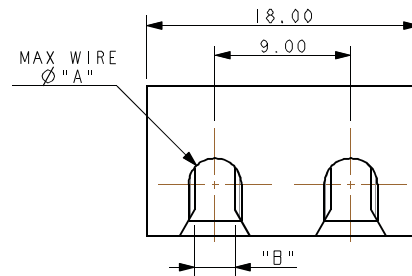
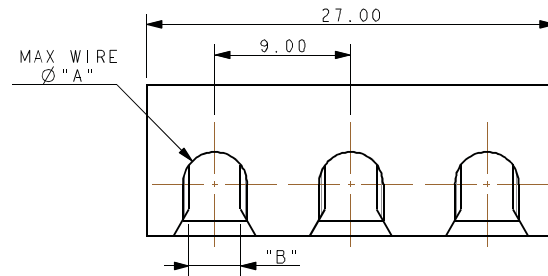
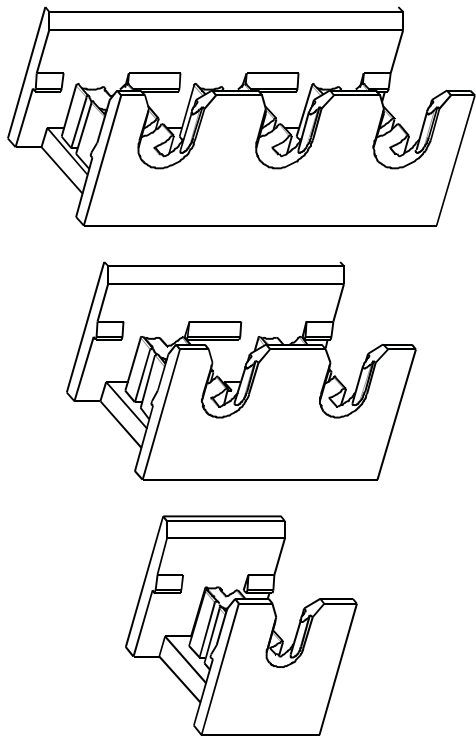

NOTES:

1. CAP FOR 9177 IDC WIRE TO BOARD CONNECTOR.
2. THROUGH WIRE CAP CAN BE USED AT ANY POSITION ALONG WIRE.
3. REFERS TO CAP, FOR WIRE MATCH TO CONNECTOR REFER TO TABLE ON PAGE 60.
4. MATERIAL: GLASS FILLED NYLON 46. FOR COLOR REFER TO PAGE 60.
5. CAPS DESIGNED TO ACCOMMODATE INSULATION DIAMETERS REFER TO PAGE 60.
6. GENERAL TOLERANCE $\pm 0.20\text{MM}$.
7. PACKED IN BAGS, 400 PIECES PER BAG.
8. APPLICATION NOTES REFER TO ELCO SPECIFICATION 201-01-124.

STANDARD 14-20 AWG: 00-9177

Insertion Tooling

INSERTION TOOLING – REQUIRES HAND PRESS WITH FLAT ROCK PLATES

1 WAY

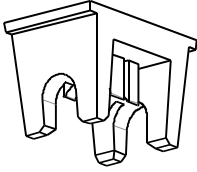

2 WAY

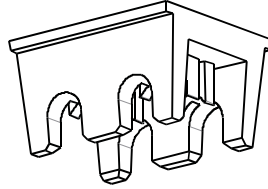

3 WAY

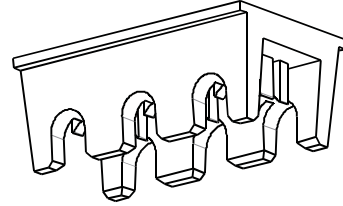

HIGH PRODUCTION
Metal

No. of Ways	Max Insulation Dia (AWG)	Tool Part Number
1	ø 4.25	06-9177-7017-01-001
	ø 3.50	06-9177-7017-02-001
	ø 2.75	06-9177-7017-03-001
2	ø 4.25	06-9177-7017-01-002
	ø 3.50	06-9177-7017-02-002
	ø 2.75	06-9177-7017-03-002
3	ø 4.25	06-9177-7017-01-003
	ø 3.50	06-9177-7017-02-003
	ø 2.75	06-9177-7017-03-003

MEDIUM PRODUCTION
Plastic

No. of Ways	Max Insulation Dia (AWG)	Tool Part Number
1	ø 4.25	06-9177-7016-01-001
	ø 3.50	06-9177-7016-02-001
	ø 2.75	06-9177-7016-03-001
2	ø 4.25	06-9177-7016-01-002
	ø 3.50	06-9177-7016-02-002
	ø 2.75	06-9177-7016-03-002
3	ø 4.25	06-9177-7016-01-003
	ø 3.50	06-9177-7016-02-003
	ø 2.75	06-9177-7016-03-003

The assembly tooling restricts the available space/component heights on the PCB. For details see below.

NOTES:

1. ALL DIMENSIONS FOR REFERENCE DIMENSIONS.
2. MAXIMUM COMPONENT HEIGHT 0.80MM IN THIS AREA.
3. MAXIMUM COMPONENT HEIGHT 11.00 MM IN THIS AREA.
4. THE SAME RESTRICTIONS APPLY TO ALL WIRE INSULATION DIAMETERS.

INSERTION TOOLING – PCB RESTRICTED AREAS FOR ASSEMBLY TOOLING

1 WAY

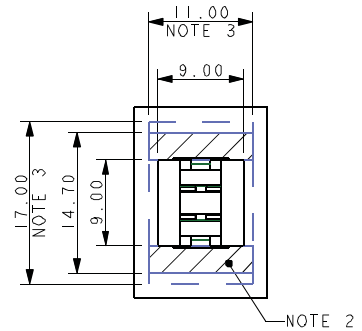
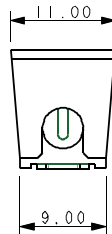
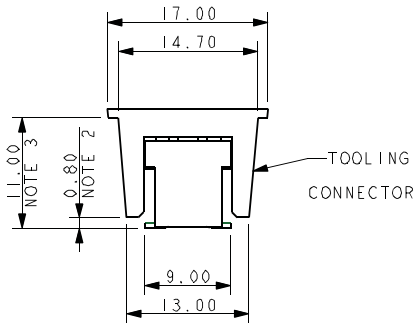

2 WAY

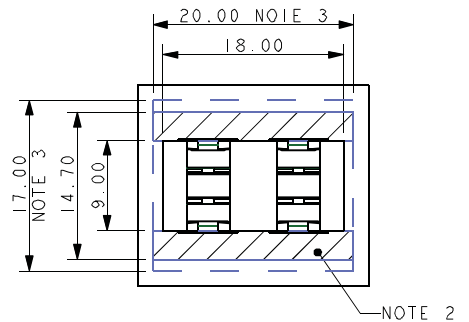
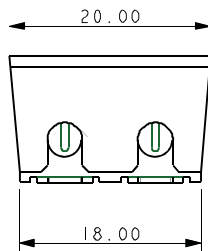
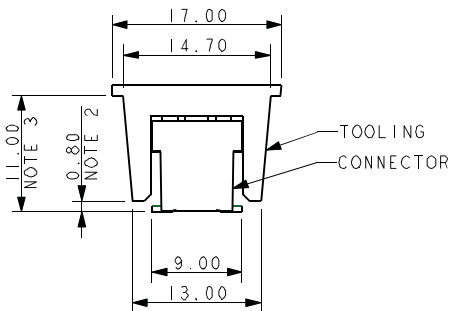

3 WAY

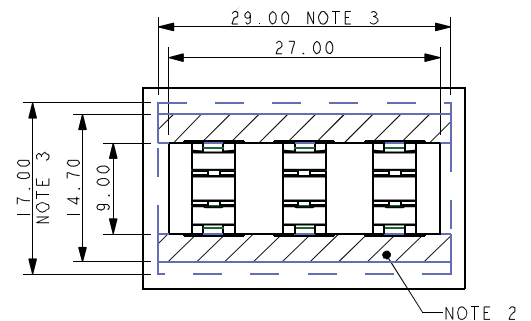
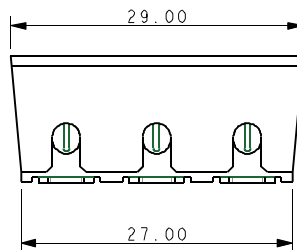
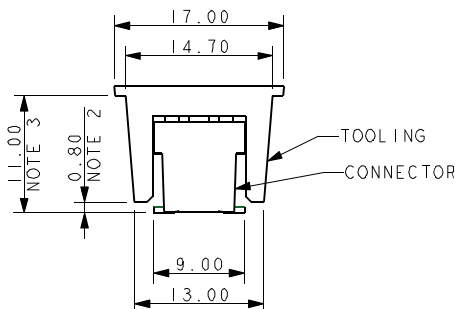

STANDARD 14-20 AWG: 00-9177

Assembled Connector

STANDARD CONNECTOR

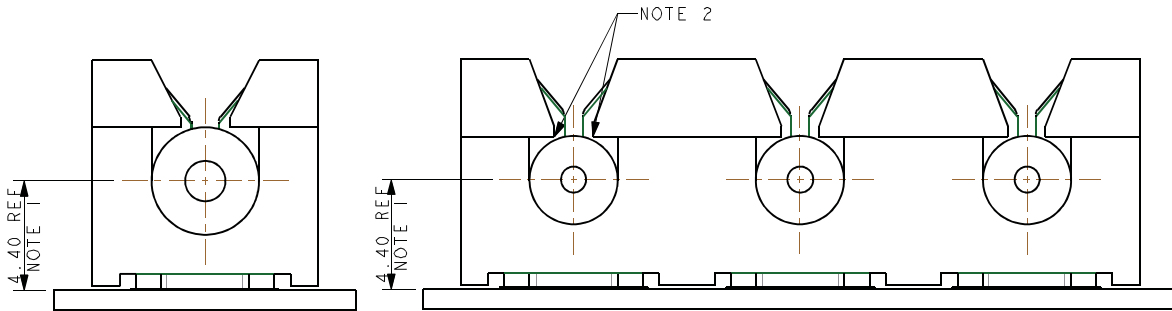

CONNECTOR WITH CAP

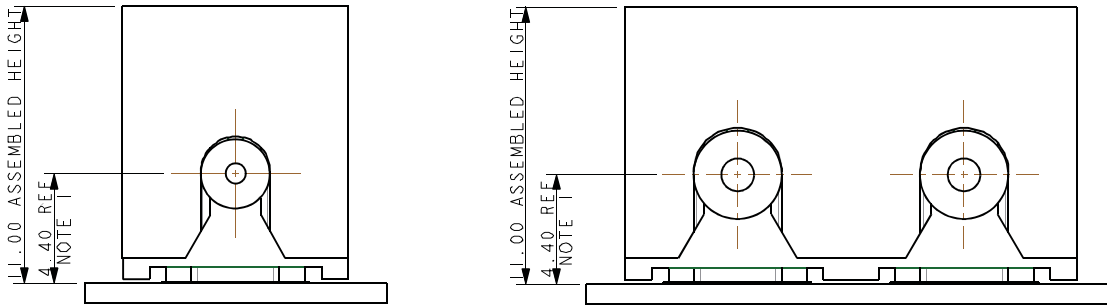

NOTES:

1. ASSEMBLED HEIGHTS INCLUDE 0.10mm ALLOWANCE FOR PAD AND SOLDER THICKNESS, NO ALLOWANCE HAS BEEN MADE FOR ANY SOLDER RESIST OR OTHER FEATURES.
2. WHEN THE WIRE IS ASSEMBLED THE INSULATION SHOULD BE TRAPPED BY THESE EDGES.

CAPPED THRU HOLE 12-18 AWG: 00-9177

General Information



KYOCERA AVX developed the initial SMT discrete wire IDC connector 5 years ago for 26- 28AWG wires. Since then, we have seen this Wire-to-Board (WTB) contact technology spread to multiple wire gauges and multiple configurations; standard connectors, capped connectors and single contacts. All of which addresses specific application or cost parameters set forth by our customer in demanding industrial, transportation or commercial applications. The heart of the IDC connector is the true “gas tight” WTB termination that is achieved once the wire is inserted between the dual phosphor bronze contact tines. These opposing tines provide enough spring characteristics to allow the termination to remain stable over extreme levels of temperature, shock and vibration.

The new 9177-600 family of contacts incorporates all of the above mentioned capabilities. From low cost single contacts to fully integrated capped contacts. The unique feature of the 600 series is the fact that it was developed for Plated Through Hole (PTH) termination to the PCB. This addresses the rugged power type boards that have to handle larger wire gauges up to 12AWG and 15 Amps per contact tines. The PTH option provides robust PCB attachment and high current capabilities to replace older technology connectors or in most cases soldering stripped wires directly to the PCB.

APPLICATIONS

- Industrial pumps, motors and driver boards
- Solar and alternative energy products
- Commercial electrical equipment
- Reference Product Specification & application notes 201-01-141/142

FEATURES AND BENEFITS

- IDC contact provides a “gas tight” wire termination to the PCB to meet harsh industrial environments
- Simple, robust design offers a high performance solution to hand soldering large gauge wires to a PCB
- A single contact can handle up to 15A for high current applications with wire replacement up to 3 times
- The versatile family of IDC contact can accept 12-18AWG of stranded wires and can be tested for compliance with solid wires

ELECTRICAL

- Current Rating: 15A
- Voltage Rating: 600 VAC

ENVIRONMENTAL

- Operating Temperature: -40°C to +125°C

MECHANICAL

- Insulator Material: Nylon 46, UL94V0
- Contact Material: Phosphor Bronze
- Plating: Tin over Nickel
- Durability: Wires can be replaced up to 3 time

HOW TO ORDER

Prefix	Series	Number of Ways	
Code	No of Ways	Details	
00	9177	00X	Page 69

Wire Insulation/Gauge Size			
Code	Style	Accepted Wire Gauge	Wire Insulation
691	Though Hole Mount	12 AWG Solid or Stranded	Ø 4.25 Max
601	Though Hole Mount	14 AWG Solid or Stranded	Ø 4.25 Max
612	Though Hole Mount	16 AWG Solid or Stranded	Ø 3.50 Max
622	Though Hole Mount	18 AWG Solid or Stranded	Ø 3.50 Max

Color/Approval			
Code	Insulator Color	Cap Type	Description
00	Black - Special Order	Through Wire	Any Position Along Wire
09	Black - Special Order	Wire Stop	End of Wire - Includes Stop
10	White - Standard	Through Wire	Any Position Along Wire
19	White - Standard	Wire Stop	End of Wire - Includes Stop

Plating Option	
6 =	Pure Tin all Over



12 - 18 AWG 1 WAY IDC CONNECTOR WIRE THROUGH CAP

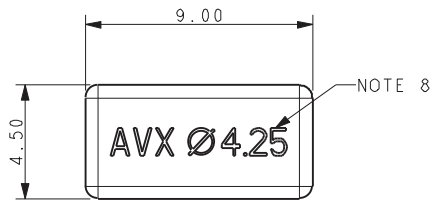

NOTES:

1. CONNECTOR FOR IDC WIRE TO BOARD CONNECTION, WIRE THROUGH CAP, CAN BE ASSEMBLED AT ANY POSITION ALONG A WIRE.
2. CONTACT MATERIAL: PHOSPHOR BRONZE. INSULATION MATERIAL: HIGH TEMP NYLON 46, UL94 V-0. COLOR REFER TO PAGE 68.
3. CONNECTOR DESIGNED TO ACCEPT BETWEEN 12 AND 18 AWG STRANDED WIRE.
4. ALL DIMENSIONS ± 0.20 UNLESS TOLERANCED.
5. FOR FULL PRODUCT SPECIFICATION ON STANDARD CONNECTORS REFER TO ELCO SPEC 201-01-141.
6. APPLICATION NOTES 201-01-142.
7. OUTLINE OF CAP. NO SPACE FOR COMPONENTS.
8. TEST TO INDICATE MAXIMUM INSULATION DIAMETER.

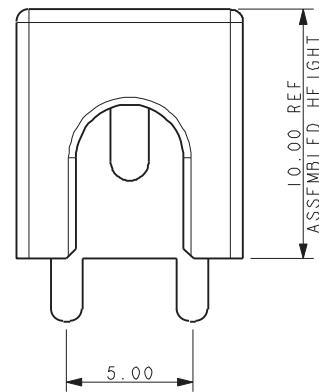
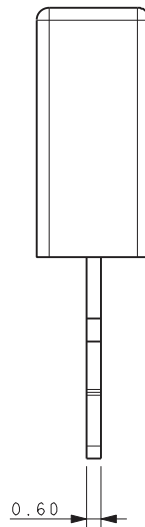
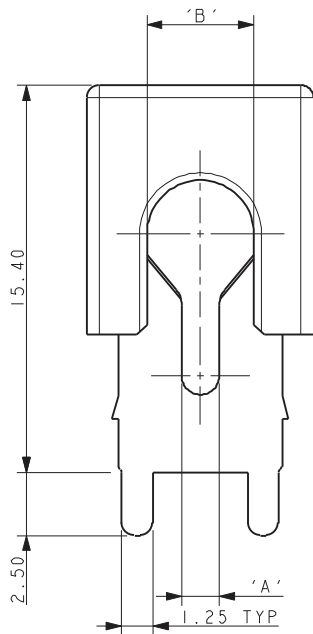

PACKING DETAILS

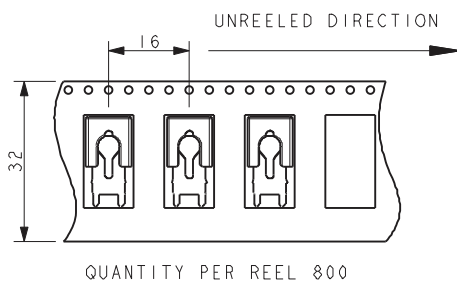
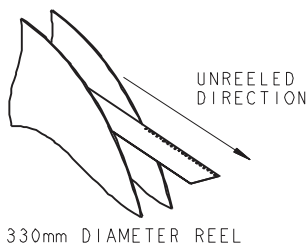

Code	Accepted Wire Gauge	A	Wire Insulation	B
691	12 AWG Solid or Stranded	1.50	Ø4.25 Max	4.25
601	14 AWG Solid or Stranded	1.10	Ø4.25 Max	4.25
612	16 AWG Solid or Stranded	0.82	Ø3.50 Max	3.50
622	18 AWG Solid or Stranded	0.72	Ø3.50 Max	3.50

SMT PCB LAYOUT PURE TIN PADS

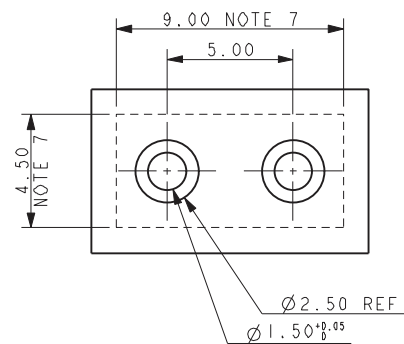

CAPPED THRU HOLE 12-18 AWG: 00-9177

1 Position - Wire Stop

12 - 18 AWG 1 WAY IDC CONNECTOR WIRE STOP CAP

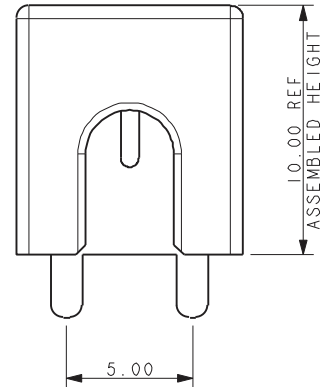
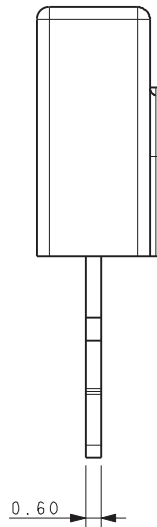
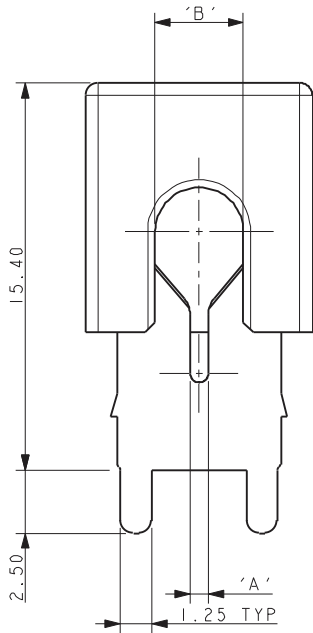
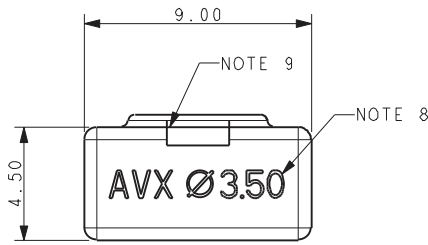

NOTES:

- CONNECTOR FOR IDC WIRE TO BORAD CONNECTION, WIRE STOP CAP, FOR USE AT WIRE END.
- CONTACT MATERIAL: PHOSPHOR BRONZE. INSULATION MATERIAL: HIGH TEMP NYLON 46, UL94 V-0. COLOR REFER TO PAGE 68.
- CONNECTOR DESIGNED TO ACCEPT BETWEEN 12 AND 18 AWG STRANDED WIRE.
- ALL DIMENSIONS ± 0.20 UNLESS TOLERANCED.
- FOR FULL PRODUCT SPECIFICATION ON STANDARD CONNECTORS REFER TO ELCO SPEC 201-01-141.
- APPLICATION NOTES 201-01-142.
- OUTLINE OF CAP. NO SPACE FOR COMPONENTS.
- TEST TO INDICATE MAXIMUM INSULATION DIAMETER.
- SLOT TO CHECK WIRE POSITION BEFORE ASSEMBLY.

PACKING DETAILS

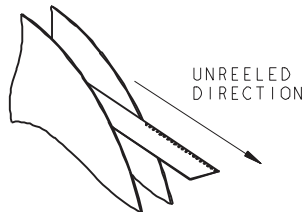

330mm DIAMETER REEL

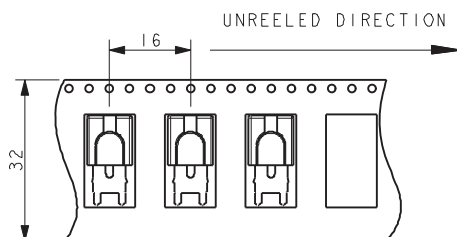

Code	Accepted Wire Gauge	A	Wire Insulation	B
691	12 AWG Solid or Stranded	1.50	Ø4.25 Max	4.25
601	14 AWG Solid or Stranded	1.10	Ø4.25 Max	4.25
612	16 AWG Solid or Stranded	0.82	Ø3.50 Max	3.50
622	18 AWG Solid or Stranded	0.72	Ø3.50 Max	3.50

SMT PCB LAYOUT

PURE TIN PADS

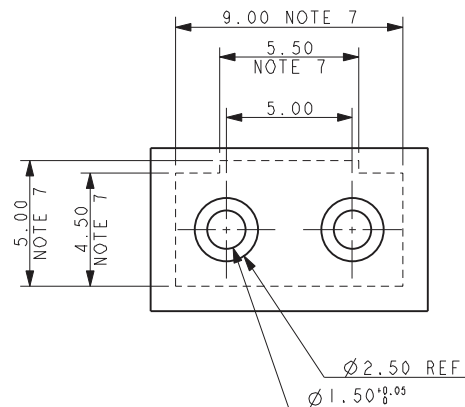

SINGLE THRU HOLE IDC CONTACT

12-18 AWG: 9177-600

General Information

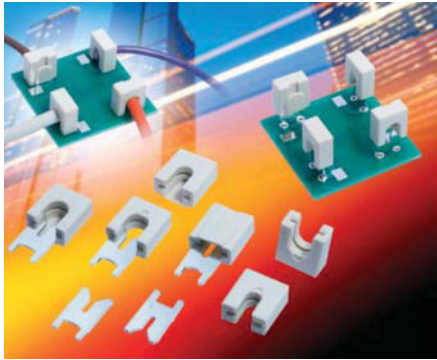

KYOCERA AVX developed the initial SMT discrete wire IDC connector 5 years ago for 26-28AWG wires. Since then, we have seen this Wire-to-Board (WTB) contact technology spread to multiple wire gauges and multiple configurations; standard connectors, capped connectors and single contacts. All of which addresses specific application or cost parameters set forth by our customer in demanding industrial, transportation or commercial applications. The heart of the IDC connector is the true “gas tight” WTB termination that is achieved once the wire is inserted between the dual phosphor bronze contact tines. These opposing tines provide enough spring characteristics to allow the termination to remain stable over extreme levels of temperature, shock and vibration.

The new 9177-600 family of contacts incorporates all of the above mentioned capabilities. From low cost single contacts to fully integrated capped contacts. The unique feature of the 600 series is the fact that it was developed for Plated Through Hole (PTH) termination to the PCB. This addresses the rugged power type boards that have to handle larger wire gauges up to 12AWG and 15 Amps per contact of current. The PTH option provides robust PCB attachment and high current capabilities to replace older technology connectors or in most cases soldering stripped wires directly to the PCB.

APPLICATIONS

- Industrial pumps, motors and driver boards
- Solar and alternative energy products
- Commercial electrical equipment
- Reference Product Specification & application notes 201-01-141/142

FEATURES AND BENEFITS

- IDC contact provides a “gas tight” wire termination to the PCB to meet harsh industrial environments
- Simple, robust design offers a high performance solution to hand soldering large gauge wires to a PCB
- A single contact can handle up to 15A for high current applications with wire replacement up to 3 times
- The versatile family of IDC contact can accept 12-18AWG of stranded wires and can be tested for compliance with solid wires

ELECTRICAL

- Current Rating: 15A
- Voltage Rating: 600 VAC

ENVIRONMENTAL

- Operating Temperature: -40°C to +125°C

MECHANICAL

- Insulator Material: Nylon 46, UL94V0
- Contact Material: Phosphor Bronze
- Plating: Tin over Nickel
- Durability: Wires can be replaced up to 3 time

HOW TO ORDER – CONTACT OPTIONS

70
Prefix
70 = Contact

9177
Series

001
Number of Ways

Code	No of Ways	Details
001	1	Page 72

6XX
Wire Gauge Size

Code	Accepted Wire Gauge
691	12 AWG Solid or Stranded
601	14 AWG Solid or Stranded
612	16 AWG Solid or Stranded
622	18 AWG Solid or Stranded

006
Plating Option
006 = Pure Tin all Over



HOW TO ORDER – CAP OPTIONS

60
Prefix
60 = Cap

9177
Series

001
Number of Ways

Code	No of Ways	Details
001	1	Pages 74-75

6XX
Wire Insulation Diameter

Code	Wire Insulation (AWG)	Diameter "A"
627	Ø 2.10 - 2.75	2.75
635	Ø 2.75 - 3.50	3.50
642	Ø 3.50 - 4.25	4.25

X
Color Options

Code	Color	Application
0	Black	Special Order
1	White	Standard

XX
Assembly Options

Code	Description
00	Through Wire
99	With Stop

SINGLE THRU HOLE IDC CONTACT

12-18 AWG: 9177-600

Contact Details

70-9177-001-6XX-006
CONTACT DETAILS

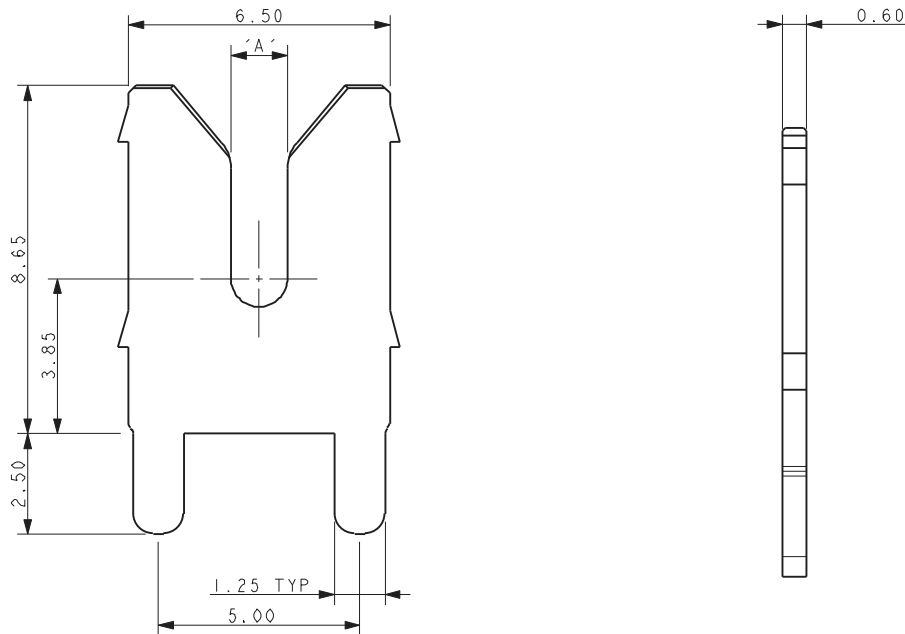

PCB LAYOUT FOR CONTACT

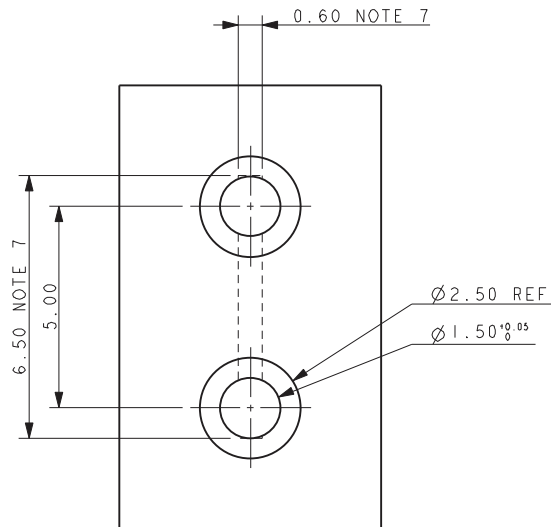

Code	Accepted Wire Gauge	A
691	12 AWG Solid or Stranded	1.50
601	14 AWG Solid or Stranded	1.10
612	16 AWG Solid or Stranded	0.82
622	18 AWG Solid or Stranded	0.72

NOTES:

1. IDC CONTACT OT ACCEPT WIRES FROM 12 AWG TO 18 AWG.
2. MATERIAL: PHOSPHOR BRONZE.
3. PLATING PURE TIN OVER NICKEL.
4. ALL DIMENSIONS ± 0.20 UNLESS SPECIFIED.
5. PACKING IN BAGS, 800 PIECES PER BAG.
6. PRODUCT SPECIFICATION REFER TO 201-01-141.
7. OUTLINE OF CONTACT SEE PAGE 71 FOR ADDITIONAL CLEARANCE REQUIRED FOR WIRE INSERTION TOOL.
8. FOR ASSEMBLY DETAILS REFER TO APPLICATION NOTES 201-01-142.

SINGLE THRU HOLE IDC CONTACT

12-18 AWG: 9177-600

Assembly Tooling

ASSEMBLY TOOLING

Part Number	Wire Insulation	A
06-9177-7021-01-000	Ø 3.50 - 4.25	425
06-9177-7021-02-000	Ø 3.50 - 4.50	350
06-9177-7021-03-000	Ø 3.50 - 2.75	275

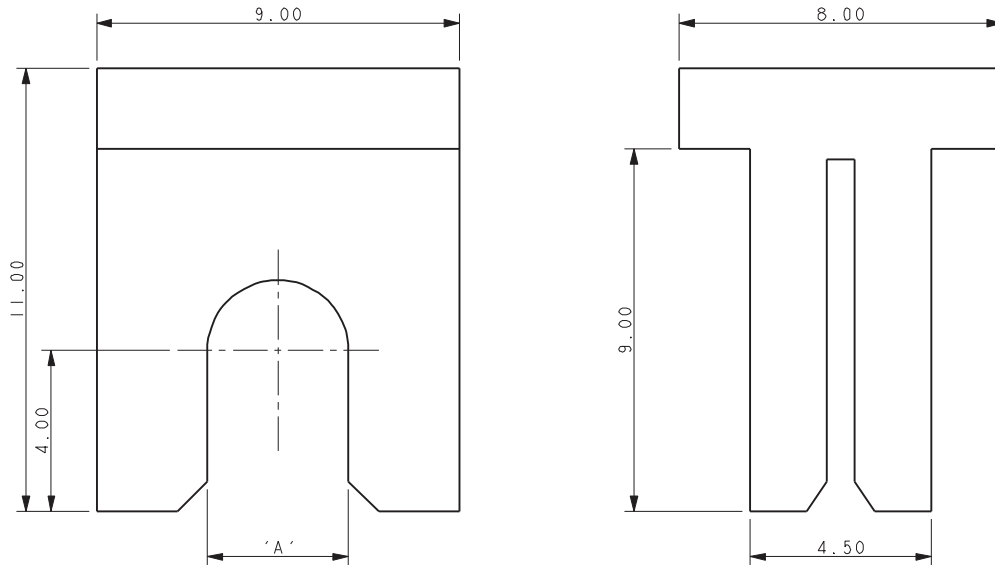

NOTES:

1. WIRE INSERTION TOOL 06-9177-7021-0X-000, FULL PART NUMBER REFER TO TABLE.
2. TOOL PART NUMBER DEPENDENT ON WIRE INSULATION DIAMETER NOT WIRE GAUGE OR CONTACT NUMBER.
3. ASSEMBLY DETAILS REFER TO APPLICATION NOTES 201-01-142
4. MATERIAL: TOOL STEEL.
5. APACE REQUIRED ON PCB FOR TOO. NO COMPONENTS IN THIS AREA.

PCB CLEARANCE AREA FOR TOOL

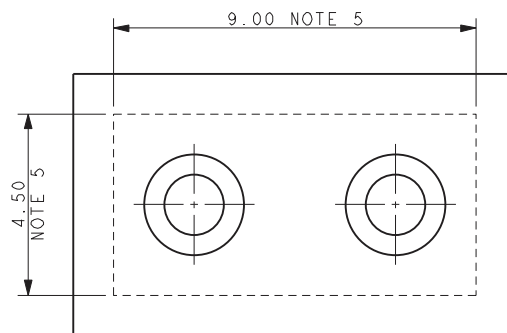

SINGLE THRU HOLE IDC CONTACT

12-18 AWG: 9177-600

Accessory Cap - Through Wire

60-9177-001-6XX-X00 1 WAY WIRE THROUGH CAP DETAILS

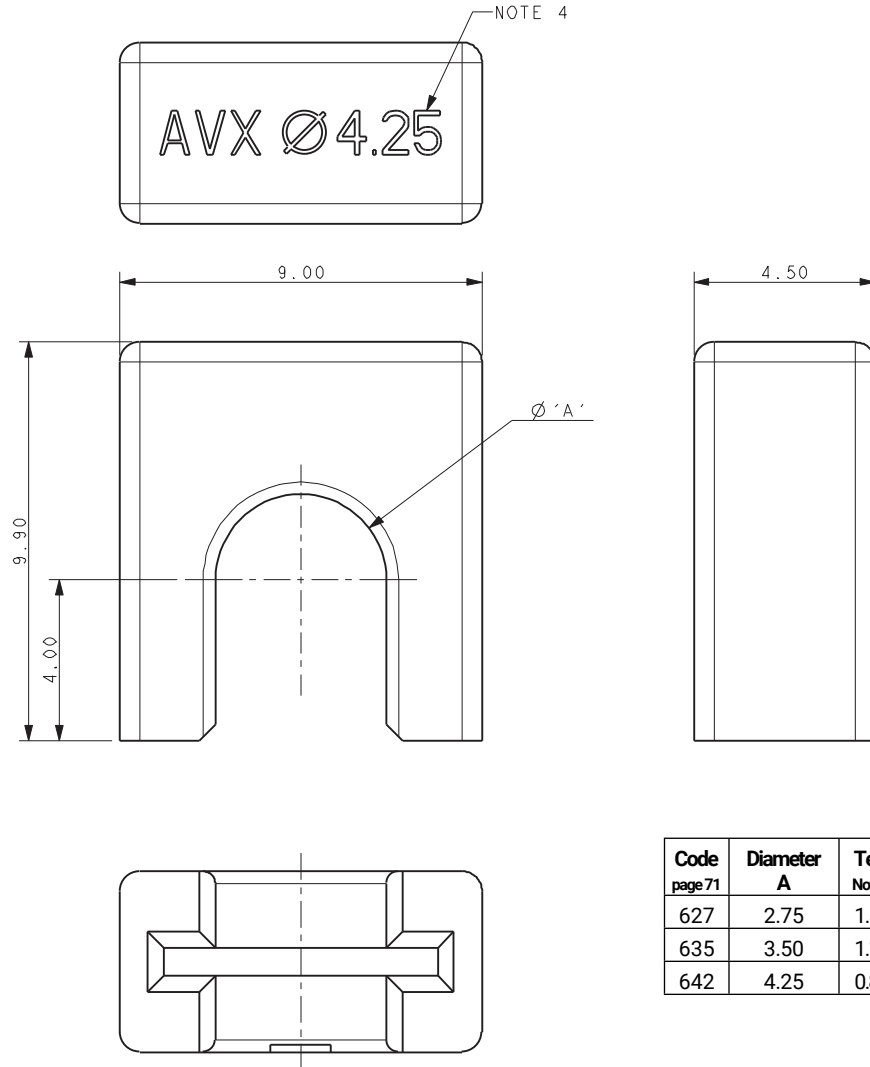

NOTES:

1. CAP FOR IDC WIRE TO BOARD CONNECTION, 1 WAY WITH THROUGH WIRE.
2. WIRE THROUGH CAP FOR ASSEMBLY AT ANY POSITION ON A WIRE.
3. CAP MATERIAL: GLASS FILLED NYLON 46, UL94 V-0. COLOR SEE PAGE 71.
4. CAP DESIGNED TO ACCOMMODATE WIRE INSULATION.
DIAMETERS 2.10MM TO 2.75MM, 2.75MM TO 3.50MM AND 3.50MM TO 4.25MM.
5. ALL DIMENSIONS ± 0.20 UNLESS STATED.
6. PACKED IN BAGS, QUANTITY 800 PIECES PER BAG.
7. PRODUCT SPECIFICATION REFER TO 201-01-141.
8. FOR ASSEMBLY DETAILS REFER TO APPLICATION NOTES 201-01-142.

SINGLE THRU HOLE IDC CONTACT

12-18 AWG: 9177-600

Accessory Cap - Wire Stop

60-9177-001-6XX-X99 1 WAY WIRE STOP CAP DETAILS

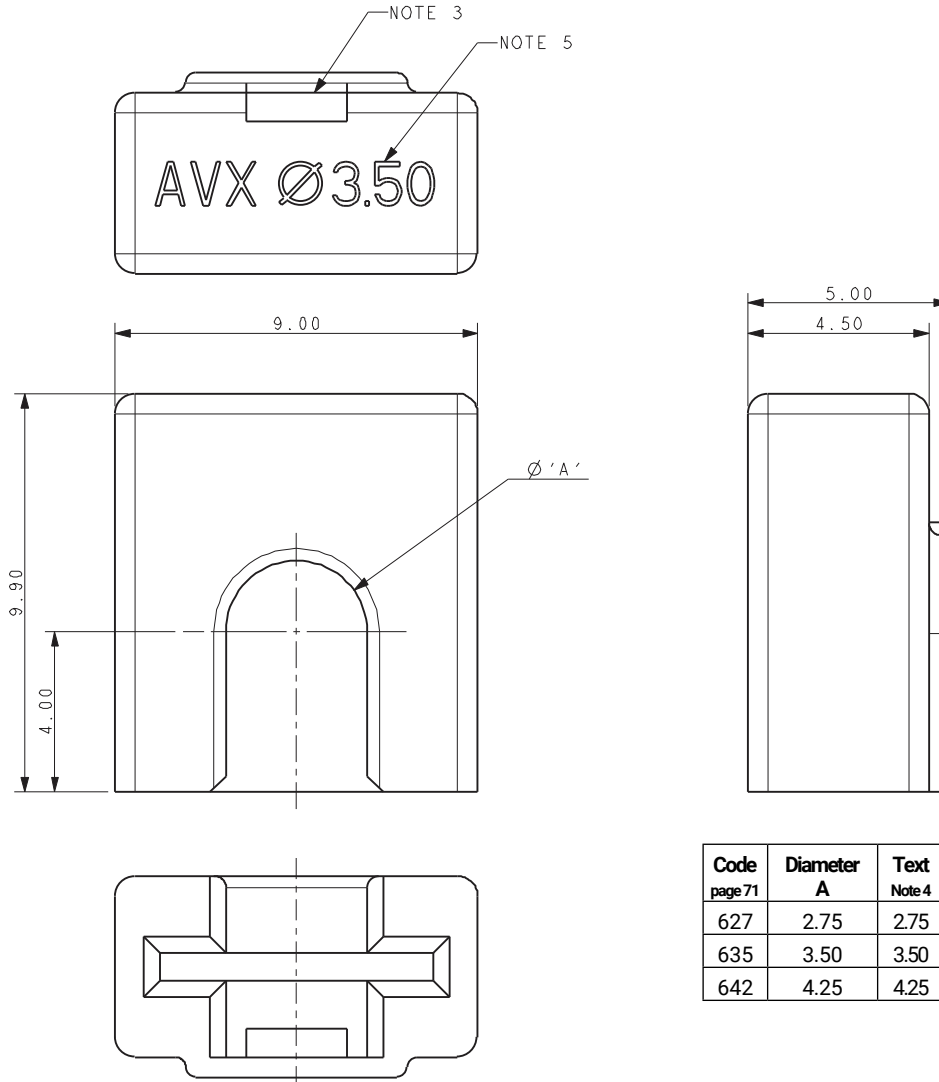

NOTES:

1. CCAP FOR IDC WIRE TO BOARD CONNECTION, 1 WAY WITH WIRE STOP.
2. WIRE STOP FOR USE AT END OF WIRE.
3. SLOT TO CHECK WIRE POSITION BEFORE ASSEMBLY.
4. CAP MATERIAL: GLASS FILLED NYLON 46, UL94 V-0. COLOR SEE PAGE 71.
5. CAP DESIGNED TO ACCOMMODATE WIRE INSULATION.
DIAMETERS 2.10MM TO 2.75MM, 2.75MM TO 3.50MM AND 3.50MM TO 4.25MM.
6. ALL DIMENSIONS ± 0.20 UNLESS STATED.
7. PACKED IN BAGS, QUANTITY 800 PIECES PER BAG.
8. PRODUCT SPECIFICATION REFER TO 201-01-141.
9. FOR ASSEMBLY DETAILS REFER TO APPLICATION NOTES 201-01-142.

POKE-HOME: HORIZONTAL

26 AWG: 00-9276

18-

General Information



The new 9276 series connector provides a quick and reliable wire-to-board termination in a sleek 2.5mm pitch SMT package for a broad range of industrial and commercial markets. With almost every product on the market today having to deal with a small number of discrete wires to connect components to a board, the 9276 series connectors meets this challenge by simply stripping the wire and inserting them into the connector. This makes the connector very termination friendly within the factory as well as in the field by electrical installers. Developed for harsh industrial and Solid State Lighting (SSL) applications, the connector was designed with a high spring force Beryllium Copper upper spring contact to accept a wide range (18-26 AWG solid or stranded) of wire to meet multiple applications with a single connector. By incorporating a dual-contact design we were able to maximize current rating (6 Amps) and minimize PCB space. For example, the 4p connector has a footprint of 90 sq-mm while competing products are 160 sq-mm. The dual-contact design also provides two solder points for each wire eliminating the need for external anchor tabs. KYOCERA AVX provides a small insertion / extraction tool which will allow the wires to easily be replaced up to 5 times.

APPLICATIONS

- Connecting discrete wire components directly to the PCB
- Bringing power and signals onto a PCB
- Daisy chaining PCB's together to create a continuous string of boards
- Application notes: refer to 201-01-127

FEATURES AND BENEFITS

- Simple strip, insert and removal design
- SMT RoHS termination to the PCB with minimal footprint
- Accepts 18-26 AWG Solid and Stranded wires
- Expanded size offering to maximize application potential; 1, 2, 3, 4, 6 & 8 positions
- High spring force top contact provides a lance type retention to capture and retain the wire
- Available in standard white and optional black color

ELECTRICAL

- Current Rating: 6 Amps / Contact
- Voltage Rating: 300 VAC

ENVIRONMENTAL

- Operating Temperature: -40°C to +125°C

MECHANICAL

- Insulator Material: Glass-Filled Nylon 46; UL94V0
- Contact Material: Beryllium Copper / Phosphor Bronze
- Plating: Tin over Nickel
- Replaceability: 5 Cycles

HOW TO ORDER

00
Wire to Board Connector

9276
Series

00X
Number of Ways

Code	No of Ways	Details
001	1	Page 78
002	2	Page 79
003	3	Page 80
004	4	Page 81
006	6	Page 82
008	8	Page 83

0
Horizontal Mountin

21
Wire Gauge Size

Code	Accepted Wire Gauge	Max Conductor	Max Insulation
21	18-26 AWG Solid or Stranded	1.20mm Diameter	2.10mm Diameter

X
Insulator Color
9 = UL White
8 = UL Black

06
Plating Option
06 = Pure Tin all Over



Thin Blade Removal Tool
Part Number 06-9276-7001-01-000

Certification: UL File #E90723

POKE-HOME: HORIZONTAL

18-26 AWG: 00-9276

Wire Assembly/Wire Extraction

WIRE ASSEMBLY

FOR FURTHER DETAILS REFER TO APPLICATION NOTES 201-01-127

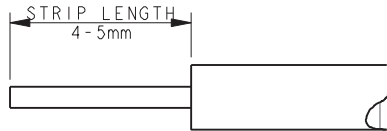

TRIM INSULATION.
DO NOT CRUSH CENTER OF WIRE.
STRANDED WIRES TWISTED TOGETHER BEFORE INSERTION.
CHECK ALL STANDS OF WIRE ARE CORRECTLY ALIGNED
AFTER THE INSULATION IS REMOVED.

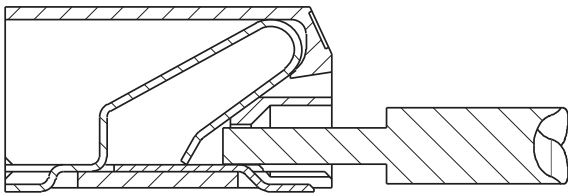

PUSH WIRE INTO HOLE IN FRONT OF CONNECTOR
DO NOT BEND CONNECTOR

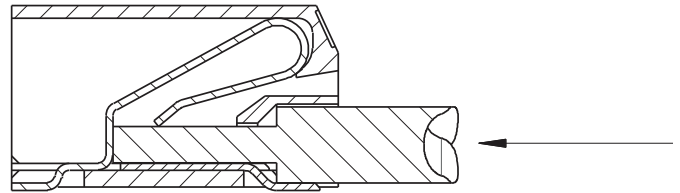

CONTINUED TO PUSH WIRE UNTIL STOP IS REACHED.

WIRE EXTRACTION

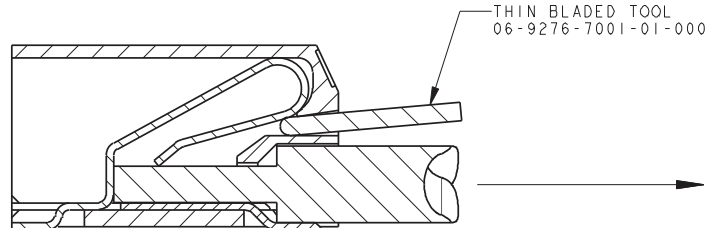

PUSH BLADE (NOT SHARP) INTO SLOT ABOVE WIRE.
WHEN WIRE IS FREE, PULL TO EXTRACT.

POKE-HOME: HORIZONTAL

18-26 AWG: 00-9276

1 Position

1 WAY WIRE TO BOARD CONNECTOR

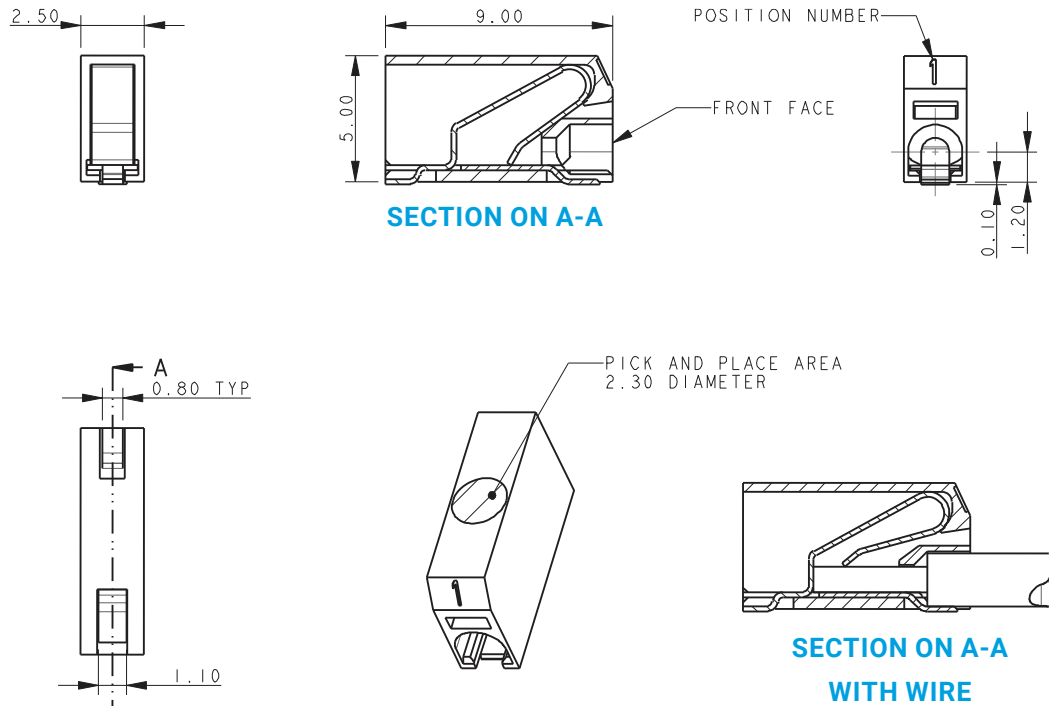

NOTES:

1. 9276 ONE WAY CONNECTOR, REFER TO ELCO SPECIFICATION 201-01-125 AND APPLICATION NOTES 201-01-127 FOR FURTHER DETAILS
2. INSULATOR MATERIAL: NYLON 46, GLASS FILLED, UL94 V-0, COLOR REFER TO PAGE 76.
3. CONTACT MATERIAL: COPPER ALLOY, 0.20MM THICK, TIN PLATED.
4. OUTLINE OF CONNECTOR.
5. WIRE ASSEMBLY / EXTRACTION, REFER TO PAGE 77.
6. FRONT FACE OF CONNECTOR CAN BE IN LINE WITH EDGE OF PCB.
7. PACKING TAPE AND REEL, QUANTITY 1000 PER REEL.

PACKING DETAILS

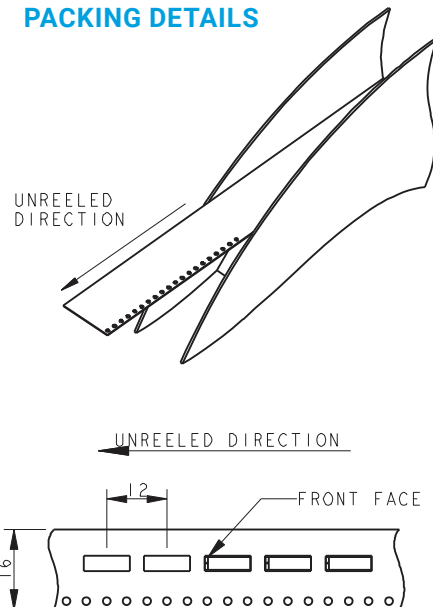

1 WAY PCB BOARD LAYOUT

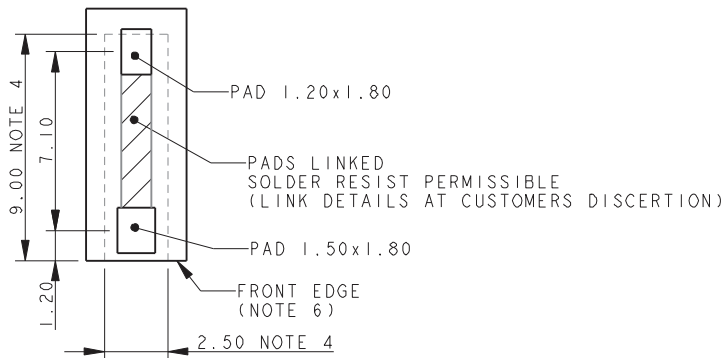

POKE-HOME: HORIZONTAL

18-26 AWG: 00-9276

2 Position

2 WAY WIRE TO BOARD CONNECTOR

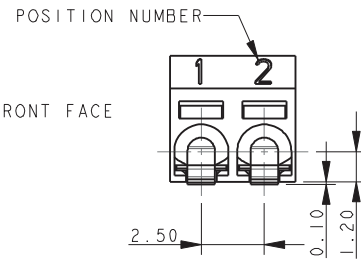
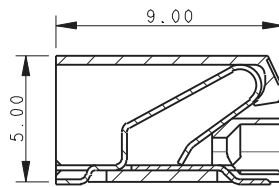
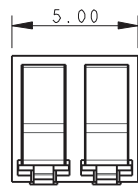

SECTION ON A-A

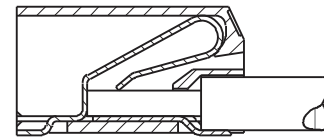
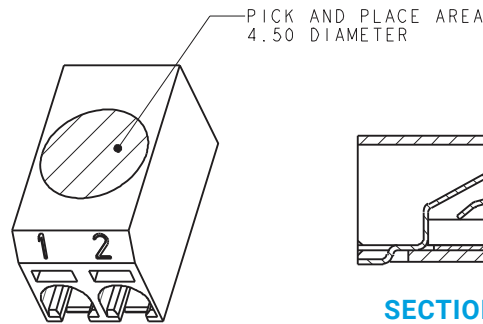
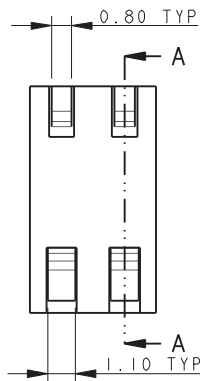

SECTION ON A-A WITH WIRE

NOTES:

1. 9276 TWO WAY CONNECTOR, REFER TO ELCO SPECIFICATION 201-01-125 AND APPLICATION NOTES 201-01-127 FOR FURTHER DETAILS
2. INSULATOR MATERIAL: NYLON 46, GLASS FILLED, UL94 V-0, COLOR REFER TO PAGE 76.
3. CONTACT MATERIAL: COPPER ALLOY, 0.20MM THICK, TIN PLATED.
4. OUTLINE OF CONNECTOR.
5. WIRE ASSEMBLY / EXTRACTION, REFER TO PAGE 77.
6. FRONT FACE OF CONNECTOR CAN BE IN LINE WITH EDGE OF PCB.
7. PACKING TAPE AND REEL, QUANTITY 1000 PER REEL.

PACKING DETAILS

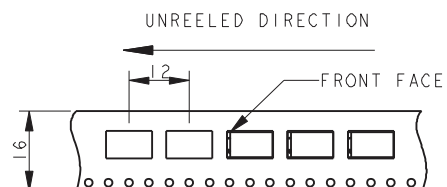
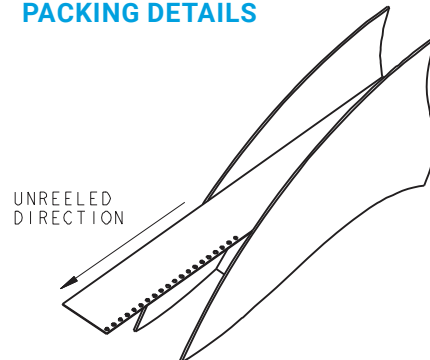

2 WAY PCB BOARD LAYOUT

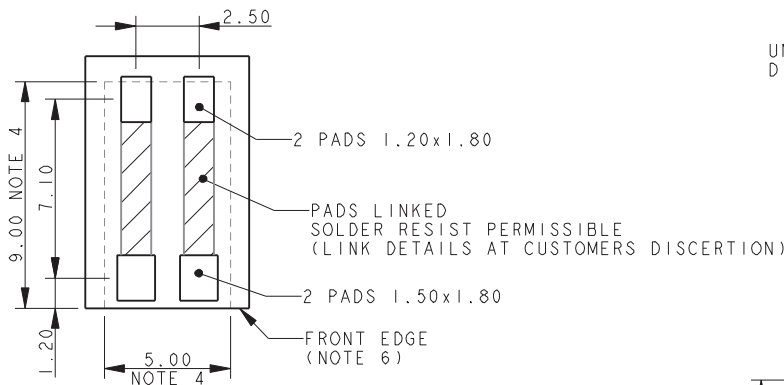

POKE-HOME: HORIZONTAL

18-26 AWG: 00-9276

3 Position

3 WAY WIRE TO BOARD CONNECTOR

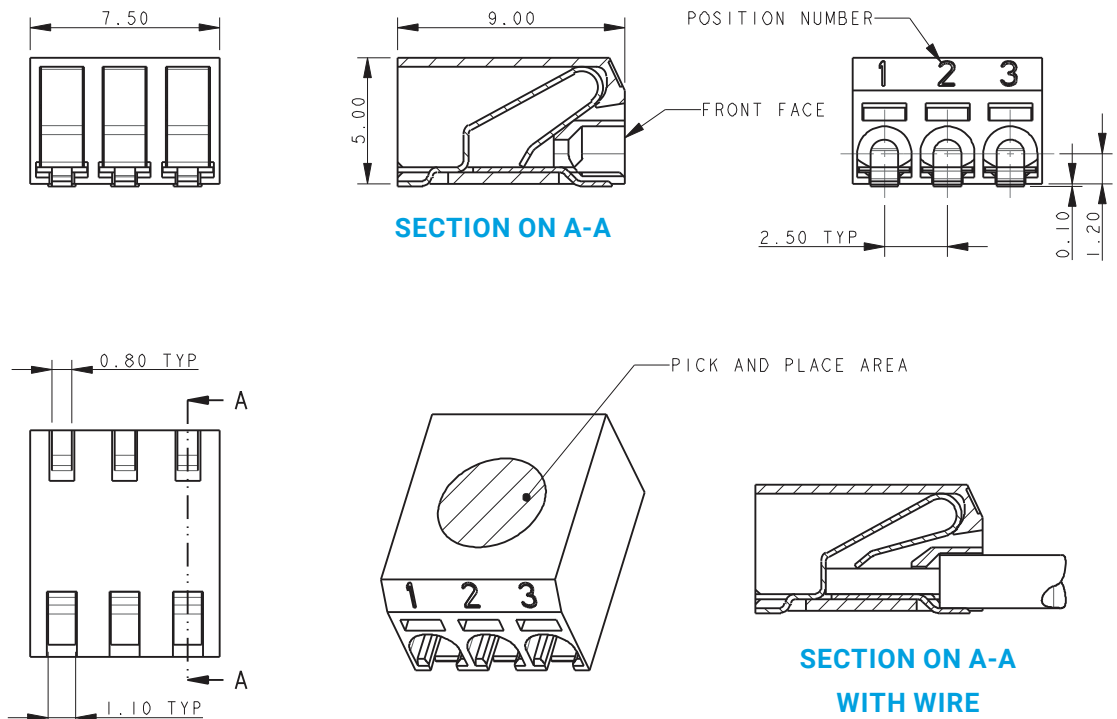

NOTES:

1. 9276 THREE WAY CONNECTOR, REFER TO ELCO SPECIFICATION 201-01-125 AND APPLICATION NOTES 201-01-127 FOR FURTHER DETAILS
2. INSULATOR MATERIAL: NYLON 46, GLASS FILLED, UL94 V-0, COLOR REFER TO PAGE 76.
3. CONTACT MATERIAL: COPPER ALLOY, 0.20MM THICK, TIN PLATED.
4. OUTLINE OF CONNECTOR.
5. WIRE ASSEMBLY / EXTRACTION, REFER TO PAGE 77.
6. FRONT FACE OF CONNECTOR CAN BE IN LINE WITH EDGE OF PCB.
7. PACKING TAPE AND REEL, QUANTITY 1000 PER REEL.

3 WAY PCB BOARD LAYOUT

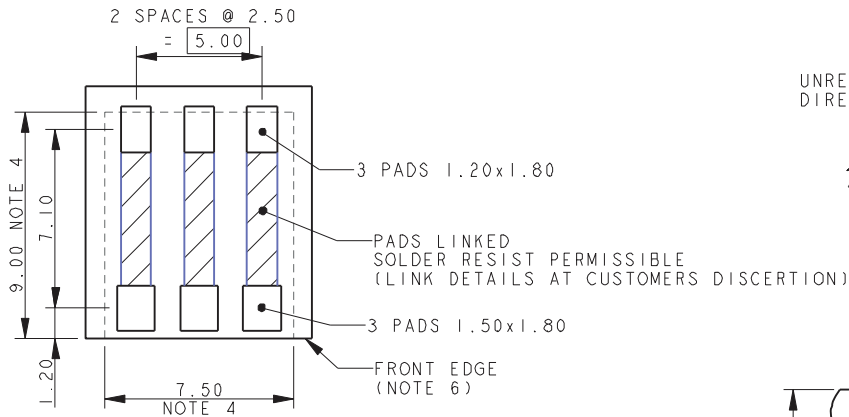

PACKING DETAILS

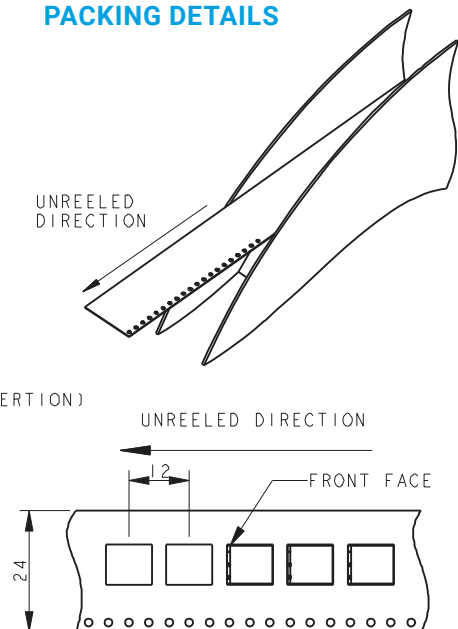

POKE-HOME: HORIZONTAL

18-26 AWG: 00-9276

4 Position

4 WAY WIRE TO BOARD CONNECTOR

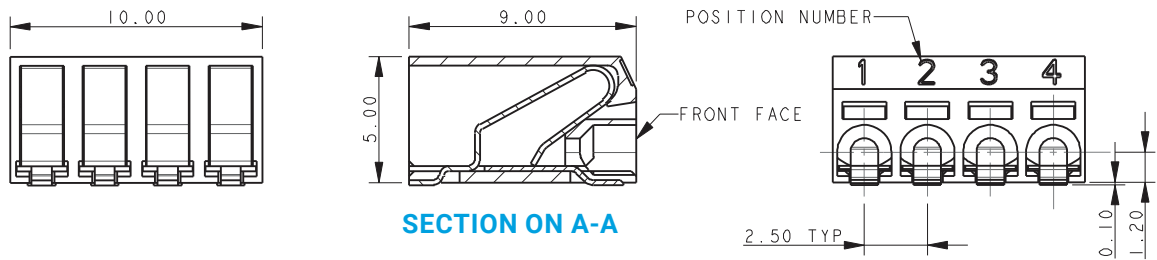

SECTION ON A-A

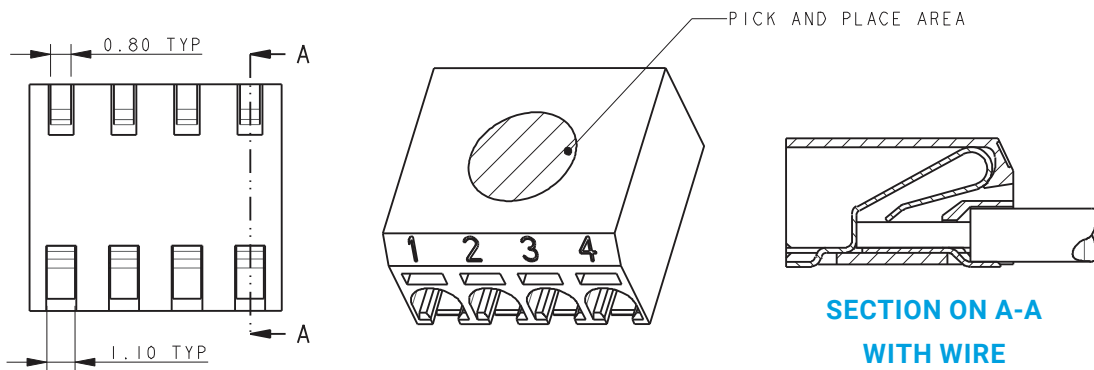

NOTES:

1. 9276 FOUR WAY CONNECTOR, REFER TO ELCO SPECIFICATION 201-01-125 AND APPLICATION NOTES 201-01-127 FOR FURTHER DETAILS
2. INSULATOR MATERIAL: NYLON 46, GLASS FILLED, UL94 V-0, COLOR REFER TO PAGE 76.
3. CONTACT MATERIAL: COPPER ALLOY, 0.20MM THICK, TIN PLATED.
4. OUTLINE OF CONNECTOR.
5. WIRE ASSEMBLY / EXTRACTION, REFER TO PAGE 77.
6. FRONT FACE OF CONNECTOR CAN BE IN LINE WITH EDGE OF PCB.
7. PACKING TAPE AND REEL, QUANTITY 1000 PER REEL.

PACKING DETAILS

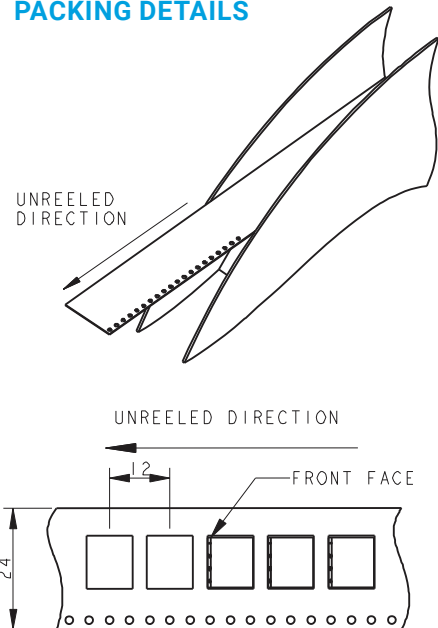

4 WAY PCB BOARD LAYOUT

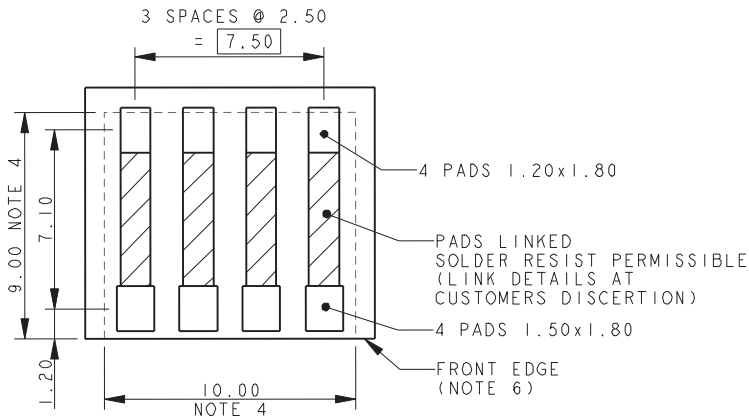

POKE-HOME: HORIZONTAL

18-26 AWG: 00-9276

6 Position

6 WAY WIRE TO BOARD CONNECTOR

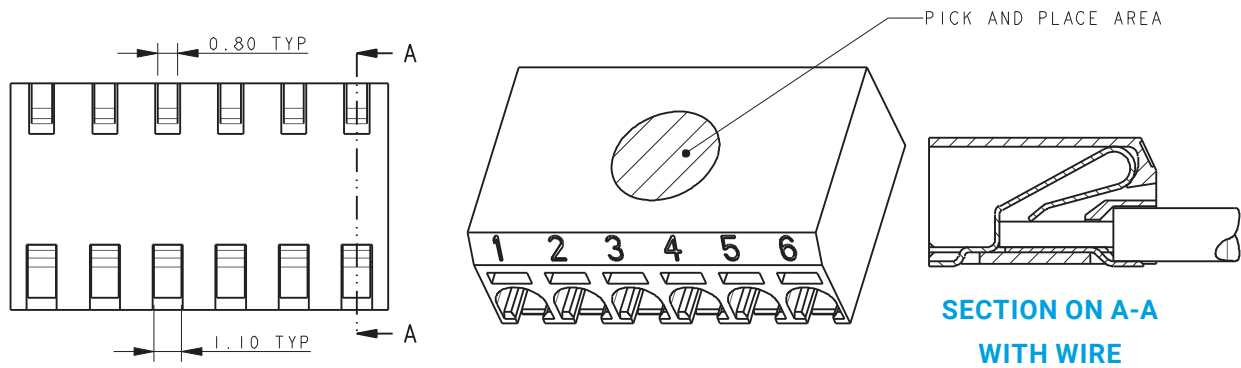
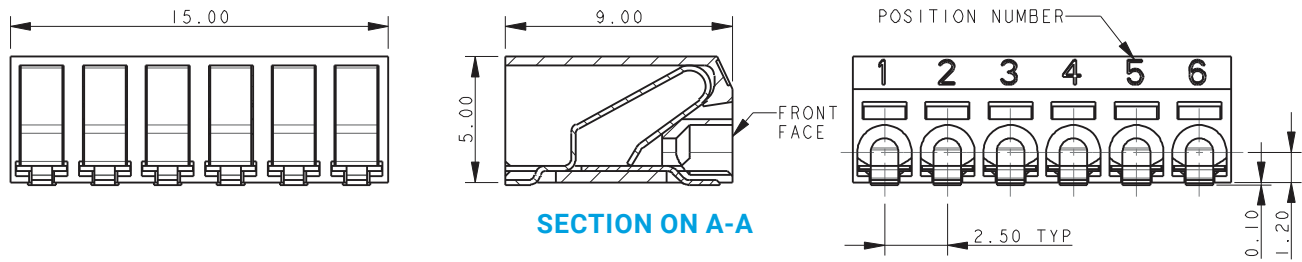

NOTES:

1. 9276 SIX WAY CONNECTOR, REFER TO ELCO SPECIFICATION 201-01-125 AND APPLICATION NOTES 201-01-127 FOR FURTHER DETAILS
2. INSULATOR MATERIAL: NYLON 46, GLASS FILLED, UL94 V-0, COLOR REFER TO PAGE 76.
3. CONTACT MATERIAL: COPPER ALLOY, 0.20MM THICK, TIN PLATED.
4. OUTLINE OF CONNECTOR.
5. WIRE ASSEMBLY / EXTRACTION, REFER TO PAGE 77.
6. FRONT FACE OF CONNECTOR CAN BE IN LINE WITH EDGE OF PCB.
7. PACKING TAPE AND REEL, QUANTITY 1000 PER REEL.

6 WAY PCB BOARD LAYOUT

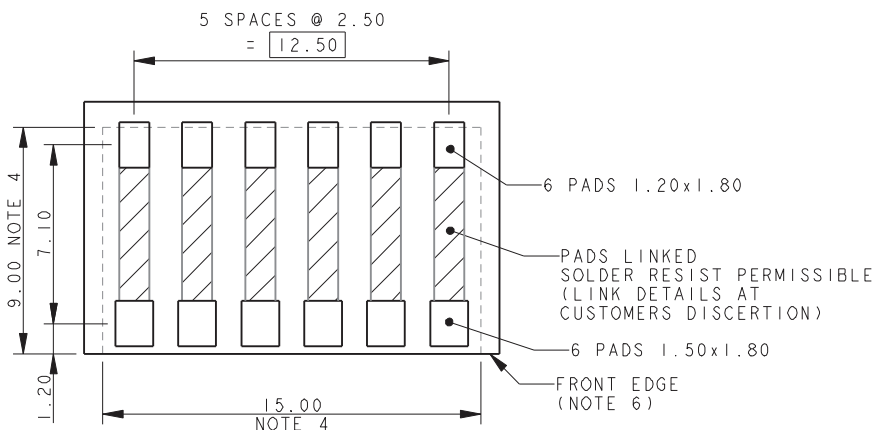

PACKING DETAILS

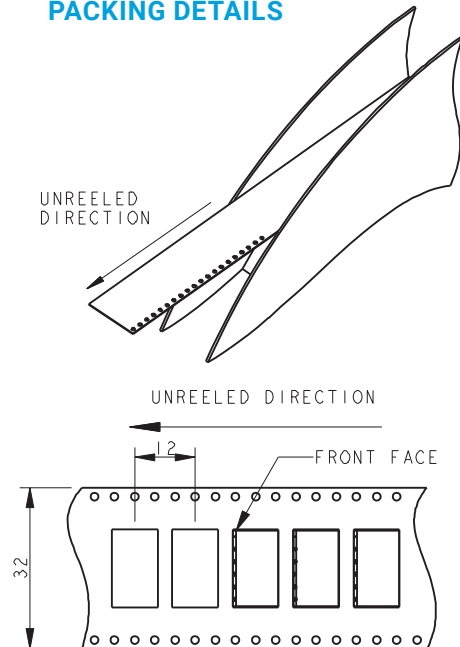

POKE-HOME: HORIZONTAL

18-26 AWG: 00-9276

8 Position

8 WAY WIRE TO BOARD CONNECTOR

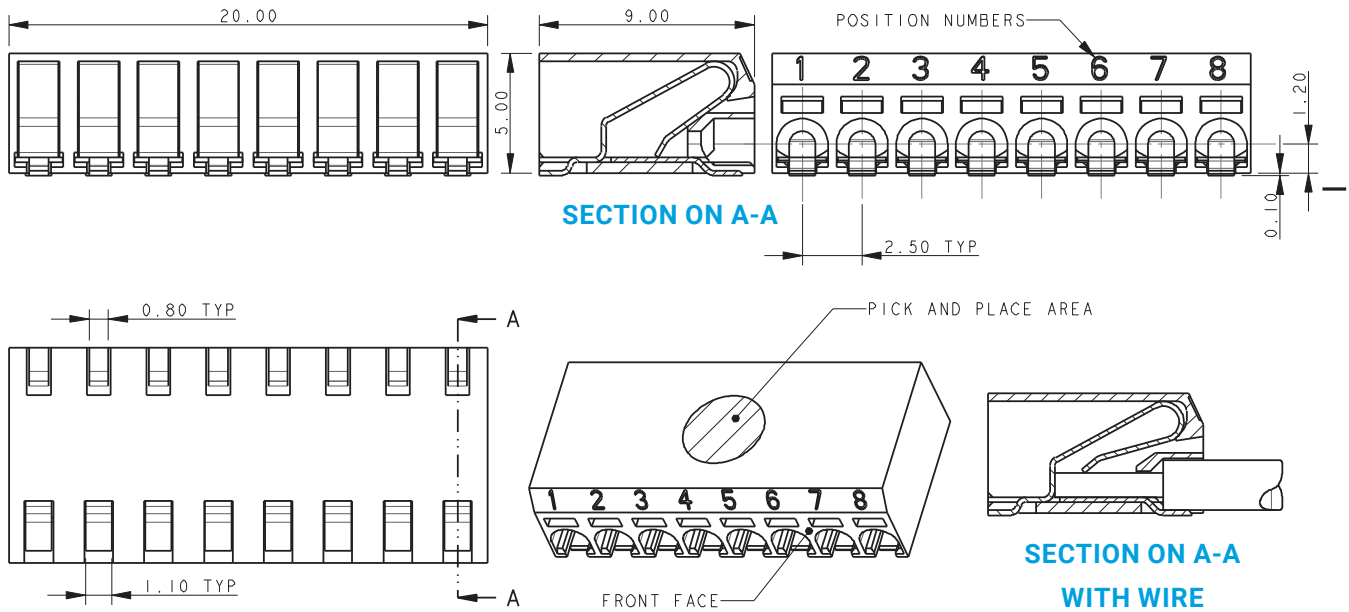

NOTES:

1. 9276 EIGHT WAY CONNECTOR, REFER TO ELCO SPECIFICATION 201-01-125 AND APPLICATION NOTES 201-01-127 FOR FURTHER DETAILS
2. INSULATOR MATERIAL: NYLON 46, GLASS FILLED, UL94 V-0, COLOR REFER TO PAGE 76.
3. CONTACT MATERIAL: COPPER ALLOY, 0.20MM THICK, TIN PLATED.
4. OUTLINE OF CONNECTOR.
5. WIRE ASSEMBLY / EXTRACTION, REFER TO PAGE 77.
6. FRONT FACE OF CONNECTOR CAN BE IN LINE WITH EDGE OF PCB.
7. PACKING TAPE AND REEL, QUANTITY 1000 PER REEL.

PACKING DETAILS

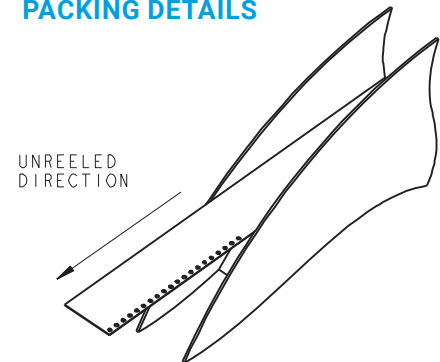

8 WAY PCB BOARD LAYOUT

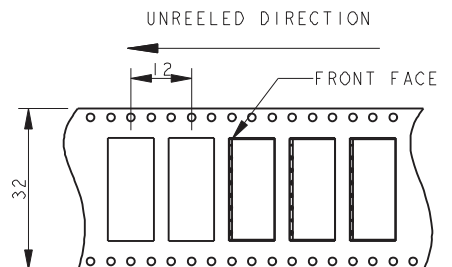
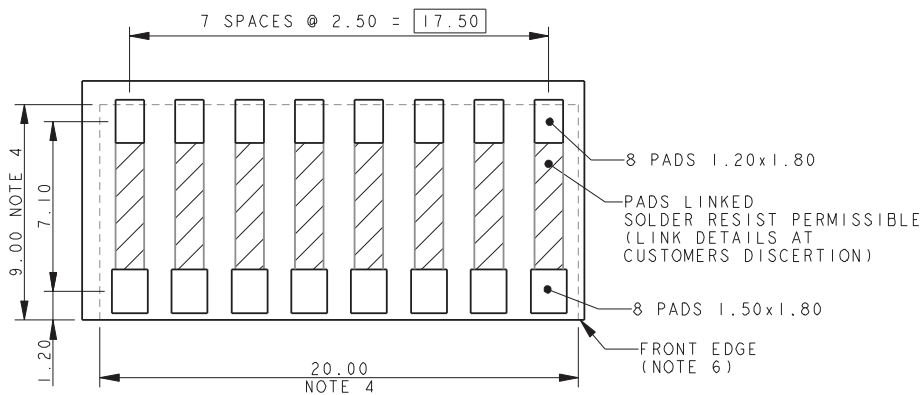

POKE-HOME: SINGLE HORIZONTAL CONTACT

12-28 AWG: 70-9296

General Information

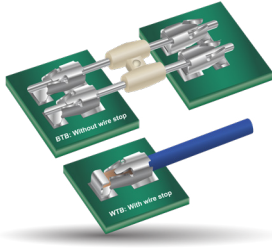

The widespread market adaptation of the KYOCERA AVX STRIPT™ contact systems continue to drive new product developments. The 70-9296 series of dual beam, boxed contacts provide a simple, yet reliable wire-to-board alternative to full sized 1pc and 2pc connector solutions. Contacts are SMT onto the PCB, then either solid or stranded wires can be stripped to length and inserted into the contact. Contacts are designed with dual beam high force contacts to maximize wire retention. Integral wire guides and stop assures proper positioning of the wire.

In this round of product expansion, the 2.5mm has been added to offer a new size when trying to maximize AWG and keep the smallest profile contact available is size critical applications. Additionally, this contact has been designed without a wire stop to facilitate solid pin insertion capabilities for board-to-board and module-to-module applications (see BTB Jumper data sheet for 109296001xxx906).

APPLICATIONS

- Industrial/Ruggedized Wire-to-Board applications
- Replace hard soldering of wire to a PCB
- Reference Product Specification 201-01-143
- Reference Application Notes 201-01-150
- Linear Board-to-Board capabilities with 109296001xxx906 jumpers

FEATURES AND BENEFITS

- Dual Beam box contact provides maximum mechanical stability and wire retention
- Tape and reel packaged for automated SMT placement
- Staged current rating based on AWG, maximum is 10A (12AWG)
- 2.5mm w/o wire stop allows for variable PCB mating tolerances in linear BTB applications

ELECTRICAL

- Voltage Rating: 300V
Based on placement distance
- Current Rating: See Matrix Below

ENVIRONMENTAL

- Operating Temperature:
-40°C to +125°C

MECHANICAL

- Contact Material: Phosphor Bronze
- Contact Plating: Pure Tin
- Durability 5 Cycles

HOW TO ORDER



Code	Contact Size	Wire Gauge	Max Insulation	UL Approved E90723
017	1.7mm Contact	22-26 AWG Solid or Stranded	1.3mm Ø (See page 85)	Yes
002	2mm Contact	22-28 AWG Solid or Stranded	1.5mm Ø (See page 85)	Yes
025	2.5mm Contact	18-26 AWG Solid or Stranded	Max 2mm Ø (See page 85)	Yes
003	3mm Contact	18-26 AWG Solid or Stranded	2.5mm Ø	Yes
004	4mm Contact	12-20 AWG Solid or Stranded	3.4mm Ø	Yes

Code	Wire Stop Variations	Plating
006	With wire stop	Pure tin all over
016*	Without wire stop	

*2mm, 2.5mm, and 3mm contact only



CURRENT RATING

Size	Part Number	12AWG	14AWG	16AWG	18AWG	20AWG	22AWG	24AWG	26AWG	28AWG
4mm	709296001004006	20A	16A	14A	12A	10A				
3mm	7092960010030x6				15A	14A	10A	9A	7A	
2.5mm	7092960010250x6				14A	12A	11A	9A	7A	
2mm	709296001002006						11A	9A	7A	6A
1.7mm	709296001017006						11A	9A	7A	6A

POKE-HOME: SINGLE HORIZONTAL CONTACT

12-28 AWG: 70-9296

1.7mm

70-9296-001-017-006 1.7MM POKE HOME CONTACT

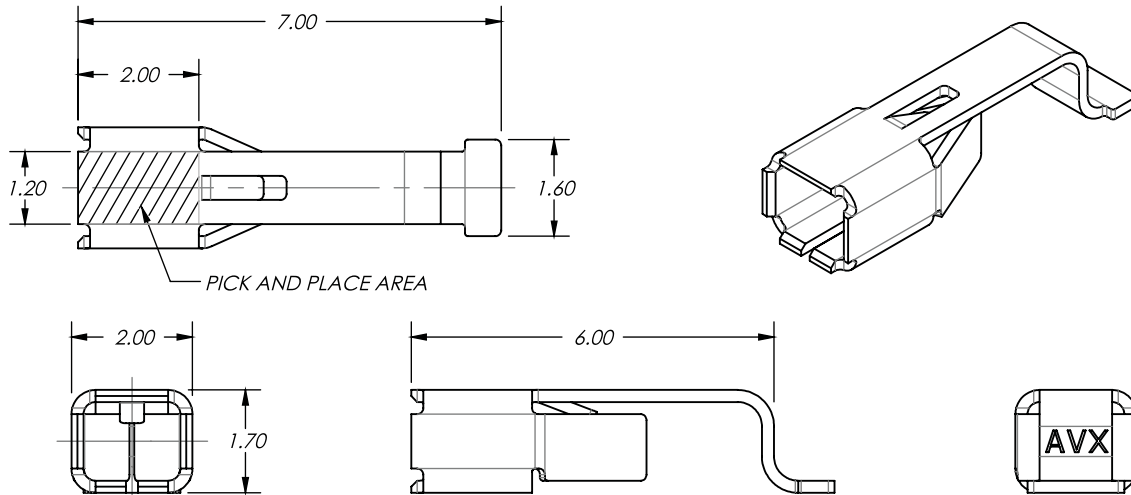

NOTES:

1. FOR FURTHER INFORMATION REFER TO ELCO SPECIFICATION 201-01-143 AND APPLICATION NOTES 201-01-150.
2. MATERIAL: TIN PLATED PHOSPHOR BRONZE.
3. PACKING IN TAPE AND REEL, 4000 PIECES PER REEL.
4. FOR WIRE TRIM DETAILS REFER TO PAGE 91.
5. AREA AVAILABLE FOR PICK AND PLACE.
6. UL REFERENCE 90723.
7. GENERAL TOLERANCE ± 0.10 .

SUGGESTED PCB LAYOUT

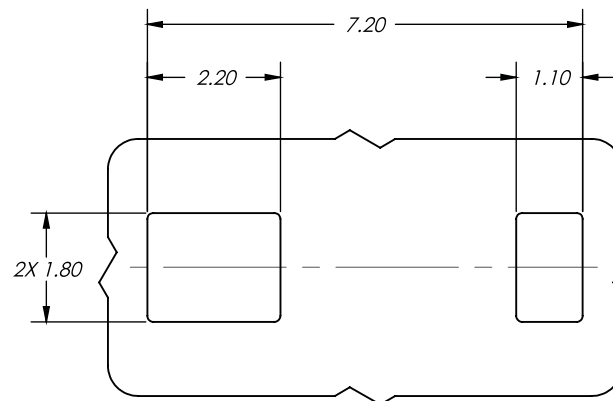

PACKING DETAILS

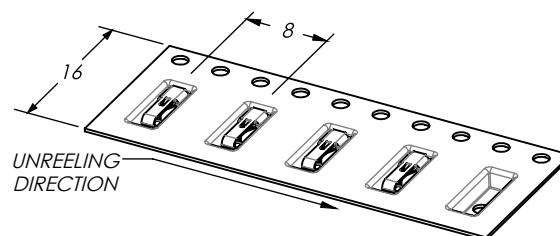

TAPE AND REEL PACKAGING
QUANTITY PER REEL: 4,000

POKE-HOME: SINGLE HORIZONTAL CONTACT

12-28 AWG: 70-9296

2mm

70-9296-001-002-006
2MM POKE HOME CONTACT

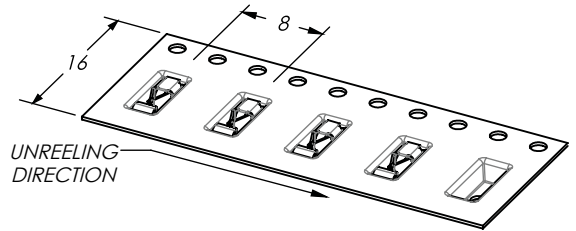
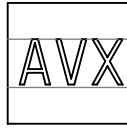
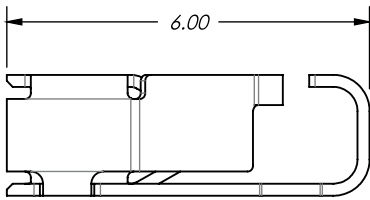
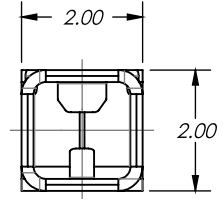
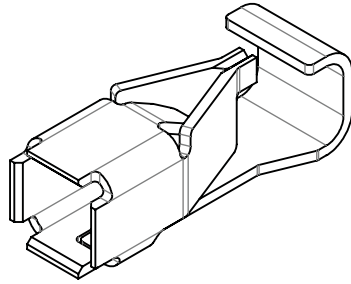
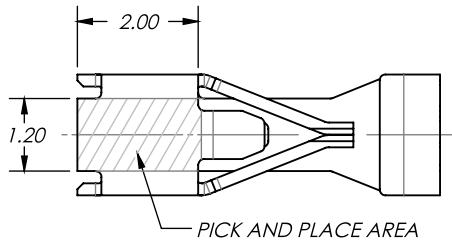

TAPE AND REEL PACKAGING
QUANTITY PER REEL: 3,500

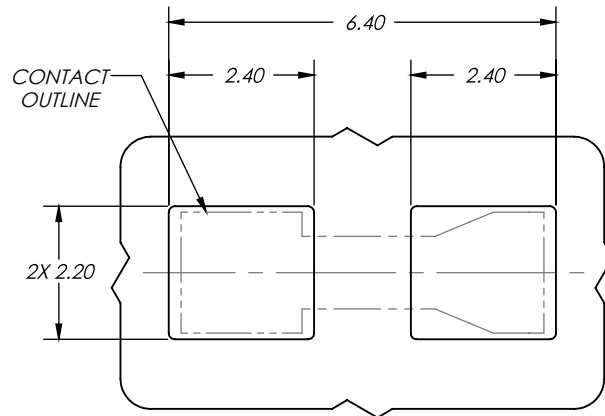

POKE-HOME: SINGLE HORIZONTAL CONTACT

12-28 AWG: 70-9296

2.5mm

70-9296-001-025-006 2.5MM POKE HOME CONTACT

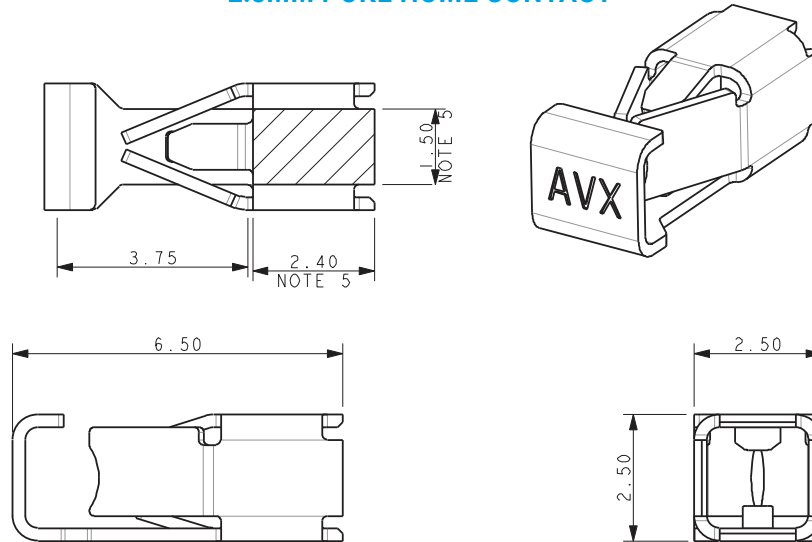

NOTES:

1. FOR FURTHER INFORMATION REFER TO ELCO SPECIFICATION 201-01-143 AND APPLICATION NOTES 201-01-150.
2. MATERIAL: TIN PLATED PHOSPHOR BRONZE.
3. PACKING IN TAPE AND REEL, 2500 PIECES PER REEL.
4. FOR WIRE TRIM DETAILS REFER TO PAGE 91.
5. AREA AVAILABLE FOR PICK AND PLACE.
6. UL REFERENCE 90723.
7. GENERAL TOLERANCE ± 0.10 .

SUGGESTED PCB LAYOUT

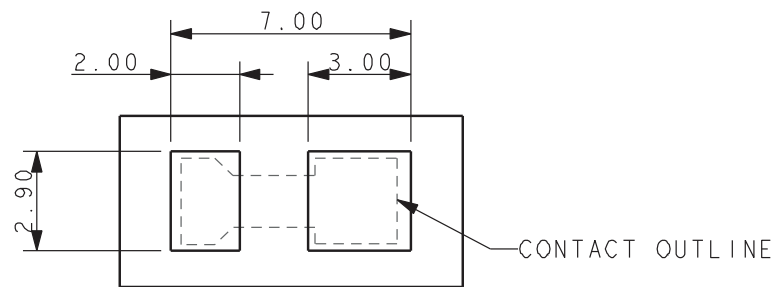

PACKING DETAILS

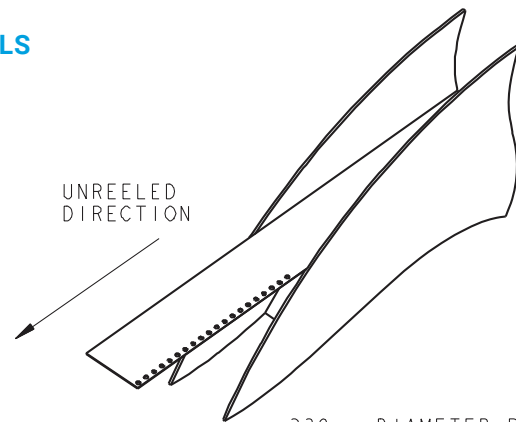
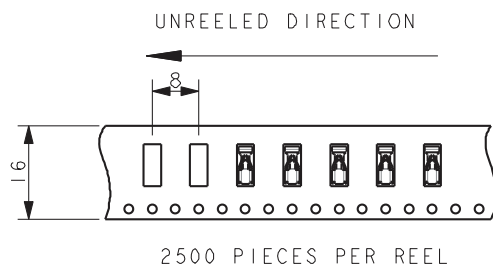

330mm DIAMETER REEL

POKE-HOME: SINGLE HORIZONTAL CONTACT

12-28 AWG: 70-9296

2.5mm – No Stop

70-9296-001-025-016

2.5MM POKE HOME CONTACT – NO STOP

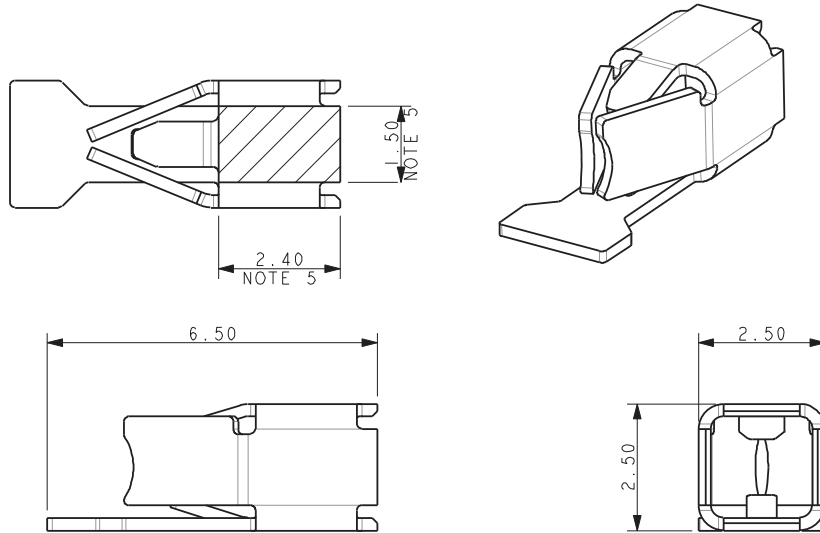

NOTES:

1. FOR FURTHER INFORMATION REFER TO ELCO SPECIFICATION 201-01-143 AND APPLICATION NOTES 201-01-150.
2. MATERIAL: TIN PLATED PHOSPHOR BRONZE.
3. PACKING IN TAPE AND REEL, 2500 PIECES PER REEL.
4. FOR WIRE TRIM DETAILS REFER TO PAGE 91.
5. AREA AVAILABLE FOR PICK AND PLACE.
6. UL REFERENCE 90723.
7. GENERAL TOLERANCE ± 0.10 .

SUGGESTED PCB LAYOUT

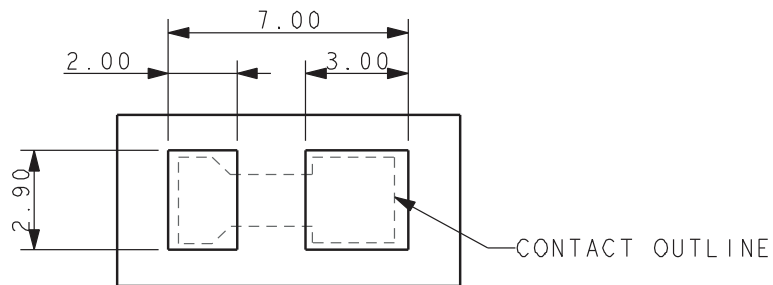

PACKING DETAILS

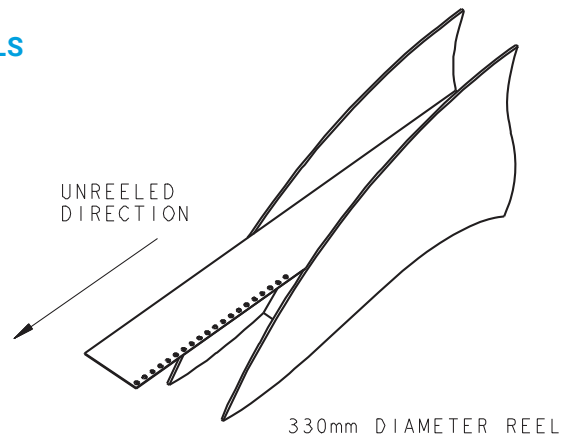
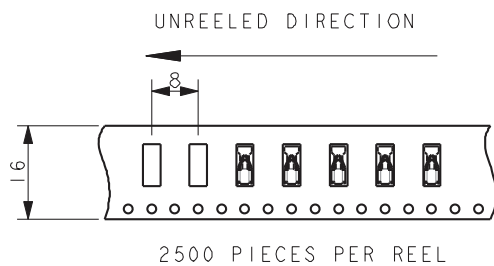

POKE-HOME: SINGLE HORIZONTAL CONTACT

12-28 AWG: 70-9296

3mm

70-9296-001-003-006 3MM POKE HOME CONTACT

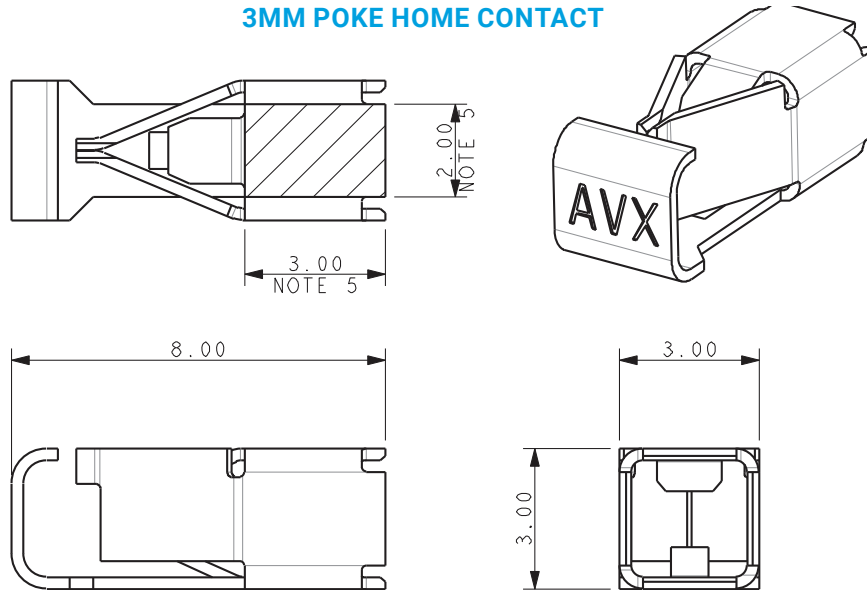

NOTES:

1. FOR FURTHER INFORMATION REFER TO ELCO SPECIFICATION 201-01-143 AND APPLICATION NOTES 201-01-150.
2. MATERIAL: TIN PLATED PHOSPHOR BRONZE.
3. PACKING IN TAPE AND REEL, 2500 PIECES PER REEL.
4. FOR WIRE TRIM DETAILS REFER TO PAGE 91.
5. AREA AVAILABLE FOR PICK AND PLACE.
6. UL REFERENCE 90723.
7. GENERAL TOLERANCE ± 0.10 .

SUGGESTED PCB LAYOUT

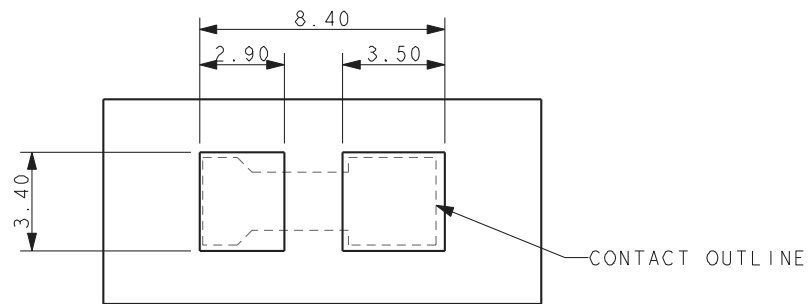

PACKING DETAILS

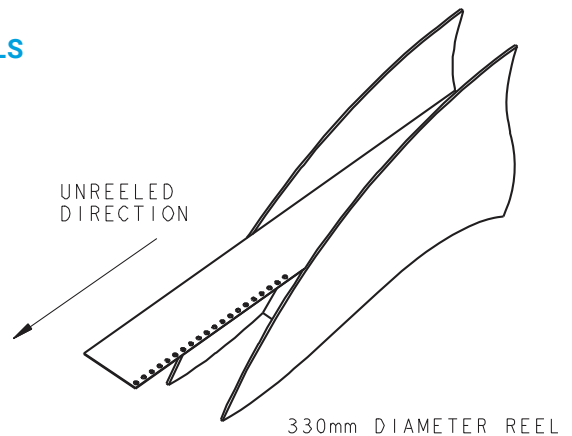
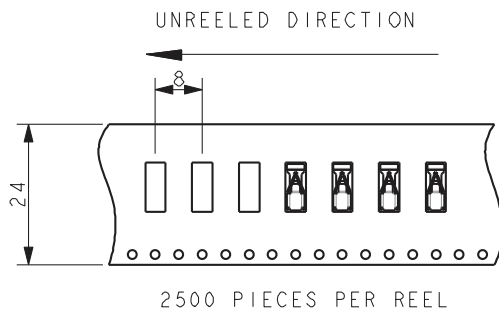

POKE-HOME: SINGLE HORIZONTAL CONTACT

12-28 AWG: 70-9296

4mm

70-9296-001-004-006 4MM POKE HOME CONTACT

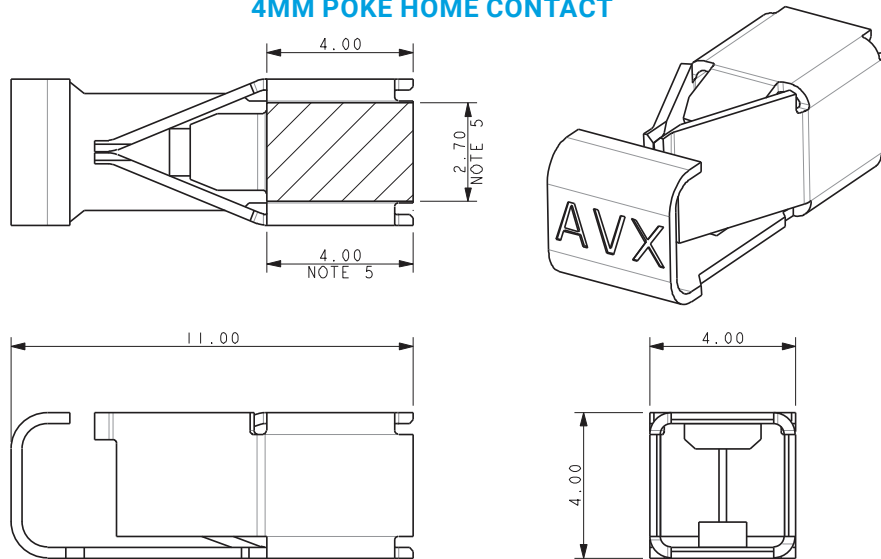

NOTES:

1. FOR FURTHER INFORMATION REFER TO ELCO SPECIFICATION 201-01-143 AND APPLICATION NOTES 201-01-150.
2. MATERIAL: TIN PLATED PHOSPHOR BRONZE.
3. PACKING IN TAPE AND REEL, 2000 PIECES PER REEL.
4. FOR WIRE TRIM DETAILS REFER TO PAGE 91.
5. AREA AVAILABLE FOR PICK AND PLACE.
6. UL REFERENCE 90723.
7. GENERAL TOLERANCE ± 0.10 .

SUGGESTED PCB LAYOUT

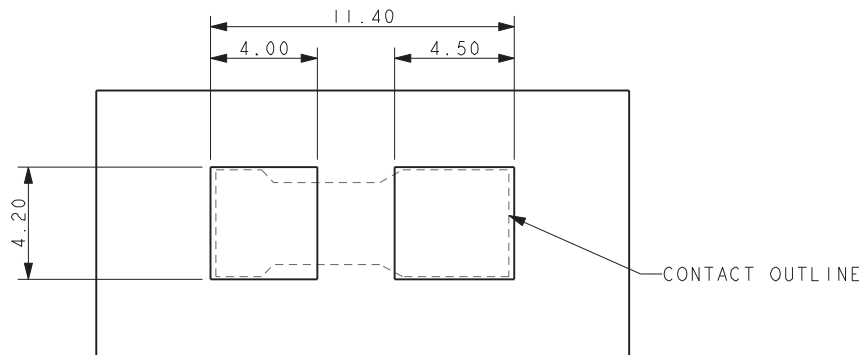

PACKING DETAILS

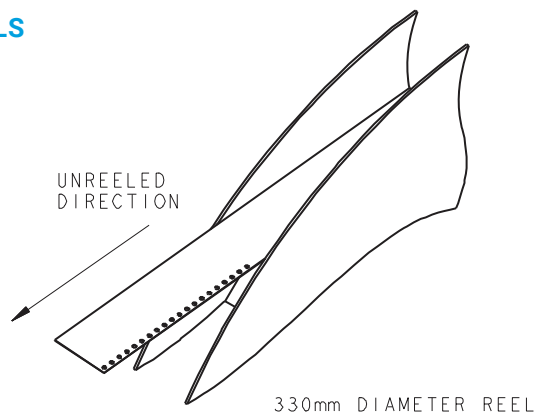
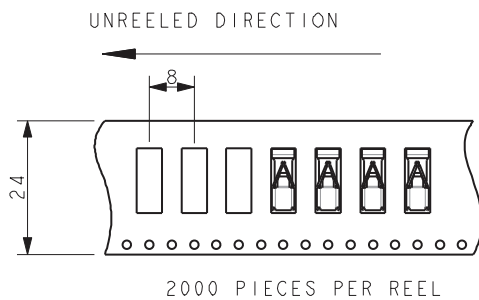

POKE-HOME: SINGLE HORIZONTAL CONTACT

12-28 AWG: 70-9296

Connector Assembly / Contact Opening Tool

CONNECTOR ASSEMBLY

FOR FULL DETAILS REFER TO APPLICATION NOTES 201-01-150

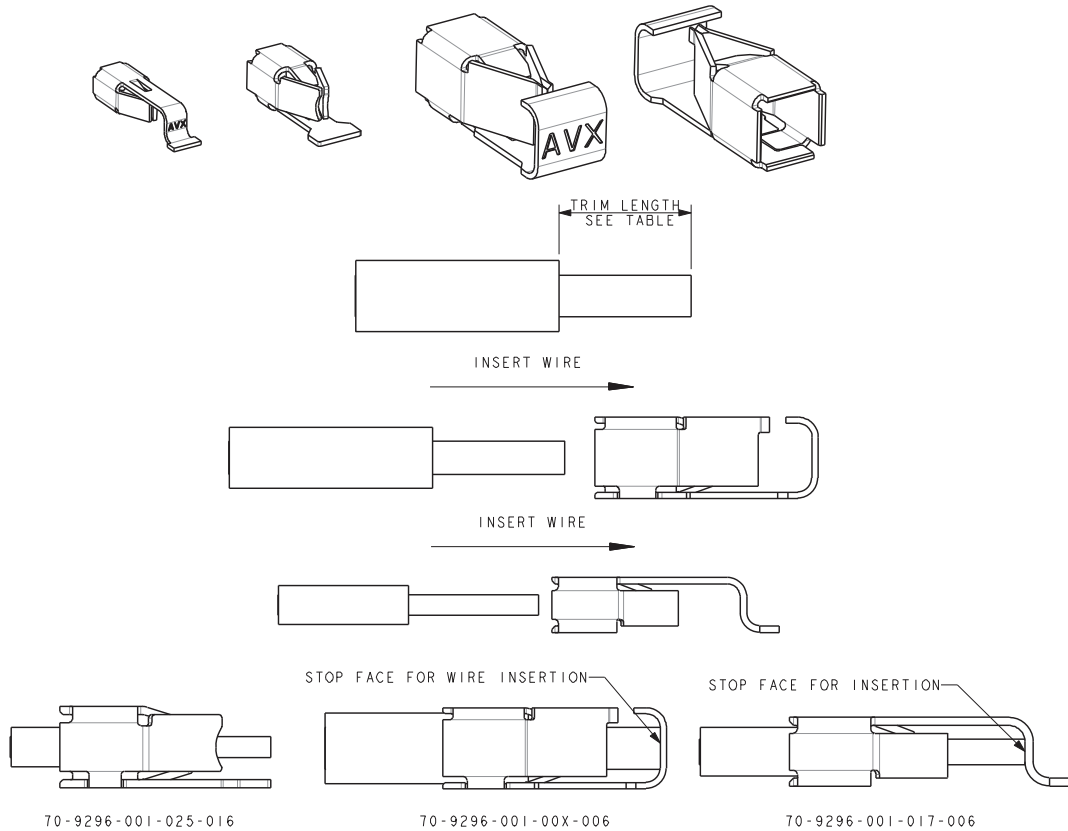

CONTACT	WIRE SIZE	INSULATOR DIAMETER	TRIM LENGTH
70-9296-001-004-006	12AWG and 14AWG	Max 3.4mm	6.5 ± 0.5mm
70-9296-001-004-006	16AWG, 18AWG and 20AWG	Max 2.5mm	5.5 ± 0.5mm
70-9296-001-003-006	18AWG to 26AWG	Max 2.5mm	4.5 ± 0.5mm
70-9296-001-025-006	20AWG to 26AWG	Max 2.0mm	3.5 ± 0.5mm
70-9296-001-025-006	20AWG to 26AWG	2.0mm to 2.50mm	6.0 ± 0.5mm*
70-9296-001-025-016	20AWG to 26AWG	Max 2.0mm	3.0mm Minimum – No Stop on Contact
70-9296-001-025-016	20AWG to 26AWG	Max 2.0mm	5.5mm Minimum – No Stop on Contact
70-9296-001-002-006	22AWG to 28AWG	Max 1.5mm	3.5 ± 0.5mm
70-9296-001-002-006	22AWG to 28AWG	1.5mm to 2.0mm	5.5 ± 0.5mm*
70-9296-001-017-006	22AWG to 26AWG	Max 1.3mm	4.0 ± 0.5mm
70-9296-001-017-006	22AWG to 26AWG	1.3mm to 1.7mm	6.0 ± 0.5mm*

* Wire insulation butts on end of contact

CONTACT OPENING TOOL

06-9296-7001-01-000

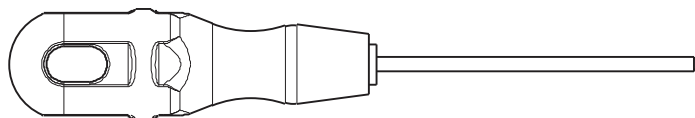

TOOL TO OPEN THE CONTACT TO INSERT/WITHDRAW WIRE.
REFER TO APPLICATION NOTES 201-01-150.

POKE-HOME: VERTICAL TOP ENTRY

18-26 AWG: 00-9296

General Information



KYOCERA AVX continues to develop innovative connectors for the industrial electronics market that provide significant benefits over existing, outdated connector solutions. Listening to the design engineering community, there are ongoing applications where they cannot find an off-the-shelf solution that will satisfy a high percentage of the projects configuration, performance and cost goals.

The newest addition to KYOCERA AVX's broadening line of Wire-to-Board (WTB) connectors offers a cost effective, single Poke-Home connector solution that will meet the cost and performance targets in demanding, yet user friendly applications. At the heart of the connector is the industry proven dual tine, 3mm high spring force box contact that has been on the market as a standalone horizontal contact only solution.

The new SMT vertical top entry connector allows for 18AWG to 26AWG wires to be simply stripped and inserted into the connector body at 180 degree orientation to the top side of the PCB. This single connector will replace existing 2-Piece WTB solutions where a header is soldered onto the PCB and a secondary crimp-to-wire receptacle assembly is plugged in. Available in 1-6 positions, each connector will accept the entire wire gauge range for either solid or stranded wires at varying current ratings supported by each wire size. Once inserted, wires can easily be removed or replaced by twisting/unscrewing or by using a small blade extraction tool.

APPLICATIONS

- Industrial/Ruggedized Wire-to-Board applications
- Replace hard soldering of wire to a PCB
- Replace costly 2-Piece header and receptacle products
- Reference Product Specification 201-01-151
- Reference Application Notes 201-01-152

FEATURES AND BENEFITS

- Dual Beam box contact provides maximum mechanical stability and wire retention
- Tape and reel packaged for automated SMT placement
- Will accept either solid or stranded wire, 18-26AWG, plated or un-plated wires
- Simple strip and insert for wire loading, with easy twist and pull for wire removal

ELECTRICAL

- Voltage Rating: 600 VAC 1 way;
300 VAC 2 - 6 way
- Current Rating: See matrix below

ENVIRONMENTAL

- Operating Temperature: -40°C to +125°C

MECHANICAL

- Contact Material: Copper Alloy
- Contact Plating: Tin over Nickel
- Durability: 5 Cycles

HOW TO ORDER

00	9296	001
Prefix	Series	Number of Ways
		001 = 1
		002 = 2
		003 = 3
		004 = 4
		005 = 5
		006 = 6

	553	
	Wire Gauge Size	
Code	Accepted Wire Gauge	Max Insulation
553	18 - 26 AWG Solid or Stranded	2.2mm

X	06
Insulator Color	Plating Options
All Sizes	06 = Tin Plated
9 = UL White (Standard)	
8 = UL Black (Special Order)	
One Way Only (Special Order)	
2 = UL Brown	
3 = UL Blue	
4 = UL Yellow	
5 = UL Red	
6 = UL Green	
7 = UL Orange	



CURRENT RATING

18AWG	20AWG	22AWG	24AWG	26AWG
7A	6A	5A	4A	3A

Certification: UL File #E90723

POKE-HOME: VERTICAL TOP ENTRY

18-26 AWG: 00-9296

1 Position

9296 TOP MOUNT POKE HOME CONNECTOR 1 WAY

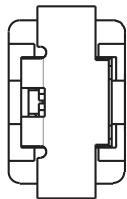
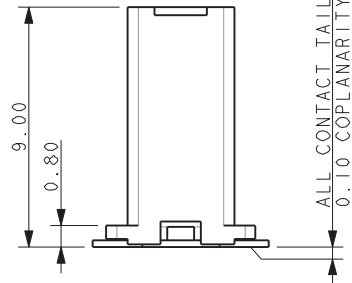
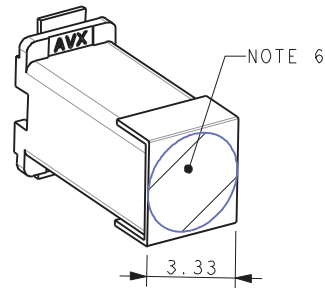
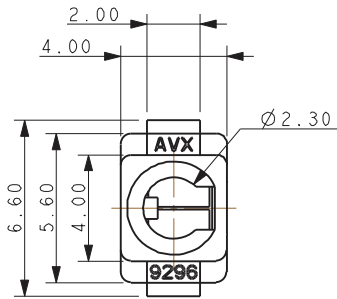

NOTES:

1. TOP MOUNT 1 WAY POKE HOME CONNECTOR. FOR FURTHER DETAILS REFER TO PRODUCT SPECIFICATION 201-01-151 AND APPLICATION NOTES 201-01-152.
2. SUITABLE FOR WIRES 18AWG TO 26AWG. MAXIMUM INSULATION 2.20MM DIAMETER.
3. INSULATOR: NYLON 46, GLASS FILLED, UL94 V-0. COLOR REFER TO PAGE 92.
4. CONTACT: TIN PLATE COPPER ALLOY.
5. PACKING IN TAPE AND REEL. QTY PER REEL 400, 330MM REEL.
6. CAPTON TAPE TO AID PICK AND PLACE, 4MM DIAMETER MAX AVAILABLE.
7. CONNECTOR OUTLINE.
8. GENERAL TOLERANCE ± 0.20 .
9. UL REFERENCE E90723.

SUGGESTED PCB LAYOUT

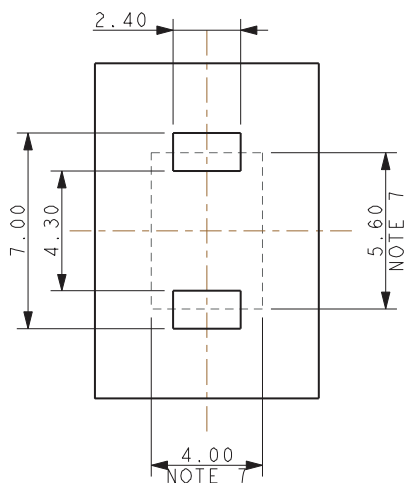

PACKING DETAILS

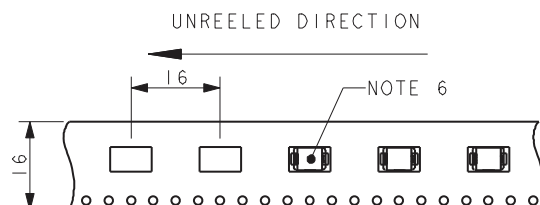
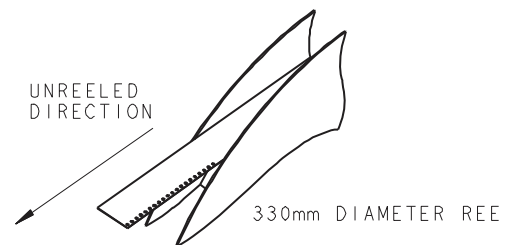

QUANTITY PER REEL 400

POKE-HOME: VERTICAL TOP ENTRY

18-26 AWG: 00-9296

2 Position

9296 TOP MOUNT POKE HOME CONNECTOR

2 WAY

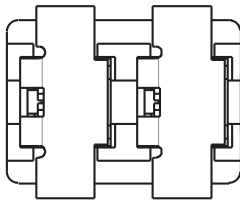
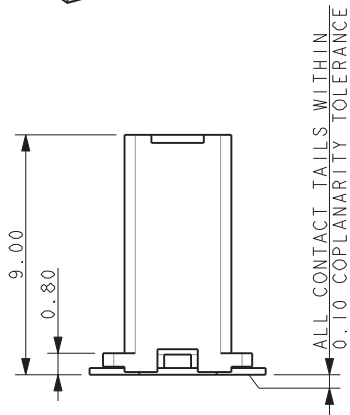
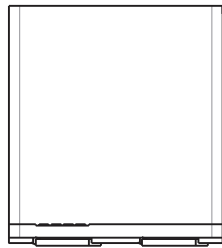
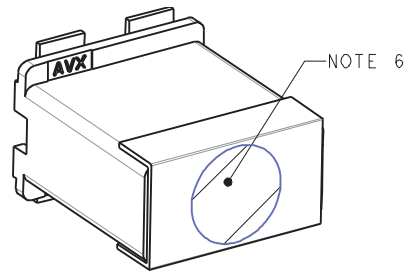
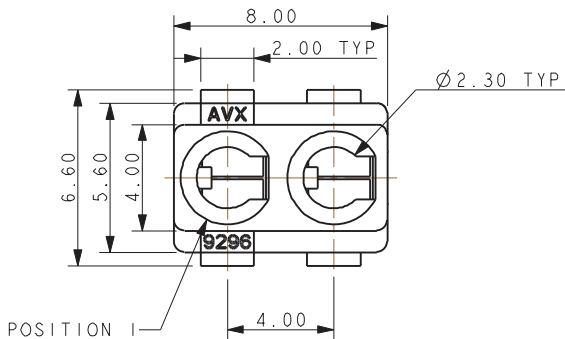

NOTES:

1. TOP MOUNT 2 WAY POKE HOME CONNECTOR. FOR FURTHER DETAILS REFER TO PRODUCT SPECIFICATION 201-01-151 AND APPLICATION NOTES 201-01-152.
2. SUITABLE FOR WIRES 18AWG TO 26AWG. MAXIMUM INSULATION 2.20MM DIAMETER.
3. INSULATOR: NYLON 46, GLASS FILLED, UL94 V-0. COLOR REFER TO PAGE 92.
4. CONTACT: TIN PLATE COPPER ALLOY.
5. PACKING IN TAPE AND REEL. QTY PER REEL 400, 330MM REEL.
6. CAPTON TAPE TO AID PICK AND PLACE, 4MM DIAMETER MAX AVAILABLE.
7. CONNECTOR OUTLINE.
8. GENERAL TOLERANCE ± 0.20 .
9. UL REFERENCE E90723.

PACKING DETAILS

SUGGESTED PCB LAYOUT

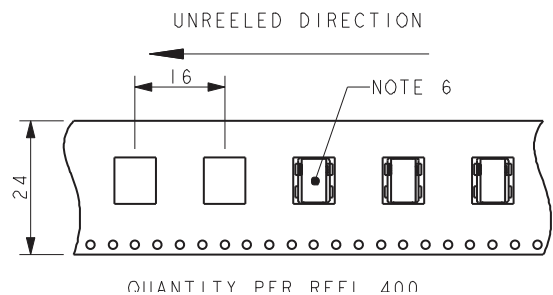
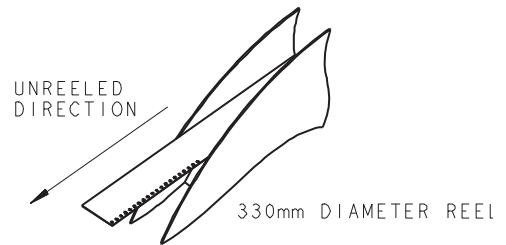
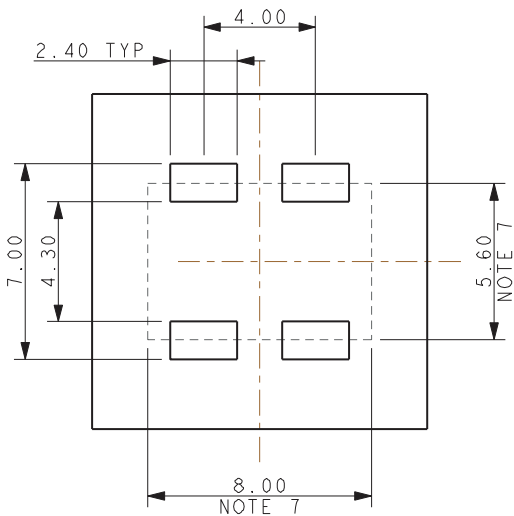

POKE-HOME: VERTICAL TOP ENTRY

18-26 AWG: 00-9296

3 Position

9296 TOP MOUNT POKE HOME CONNECTOR 3 WAY

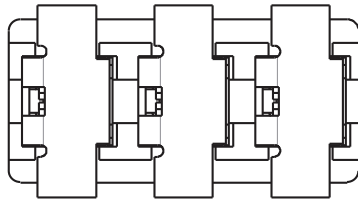
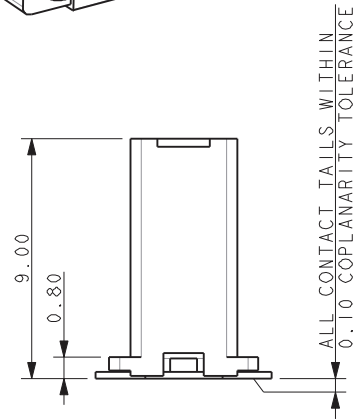
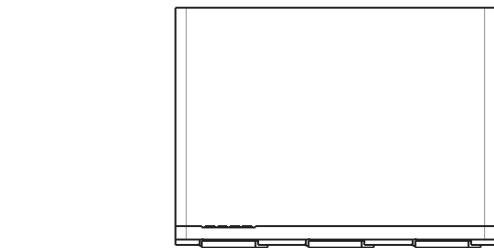
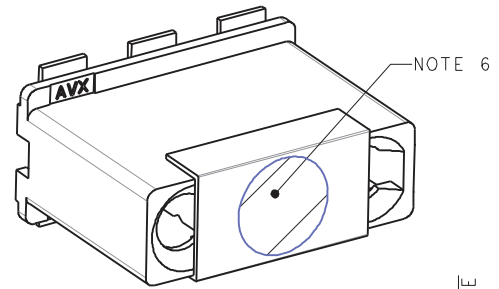
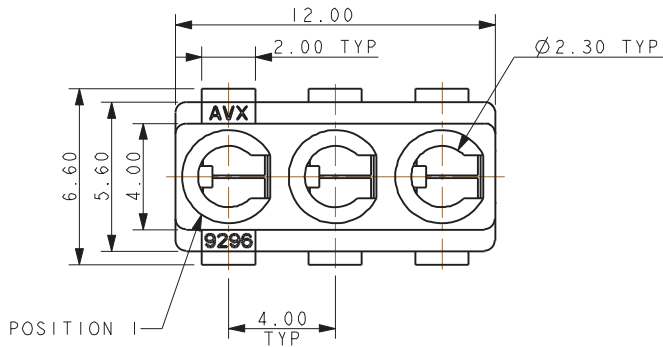

NOTES:

1. TOP MOUNT 3 WAY POKE HOME CONNECTOR. FOR FURTHER DETAILS REFER TO PRODUCT SPECIFICATION 201-01-151 AND APPLICATION NOTES 201-01-152.
2. SUITABLE FOR WIRES 18AWG TO 26AWG. MAXIMUM INSULATION 2.20MM DIAMETER.
3. INSULATOR: NYLON 46, GLASS FILLED, UL94 V-0. COLOR REFER TO PAGE 92.
4. CONTACT: TIN PLATE COPPER ALLOY.
5. PACKING IN TAPE AND REEL. QTY PER REEL 400, 330MM REEL.
6. CAPTON TAPE TO AID PICK AND PLACE, 4MM DIAMETER MAX AVAILABLE.
7. CONNECTOR OUTLINE.
8. GENERAL TOLERANCE ± 0.20 .
9. UL REFERENCE E90723.

SUGGESTED PCB LAYOUT

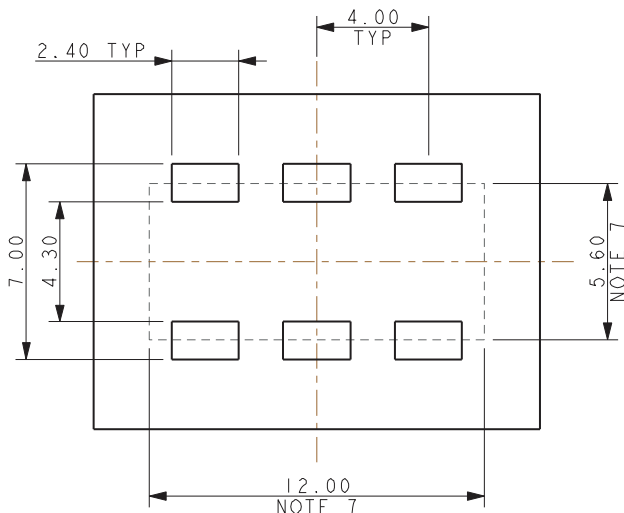

PACKING DETAILS

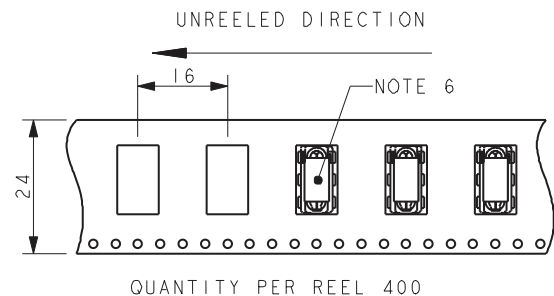
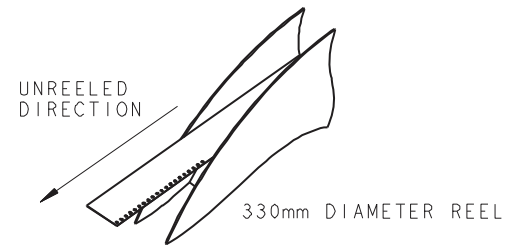

POKE-HOME: VERTICAL TOP ENTRY

18-26 AWG: 00-9296

4 Position

9296 TOP MOUNT POKE HOME CONNECTOR

4 WAY

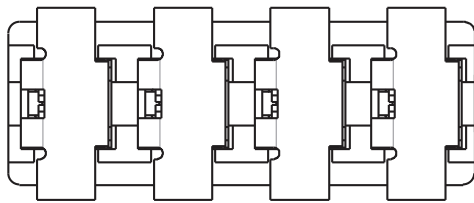
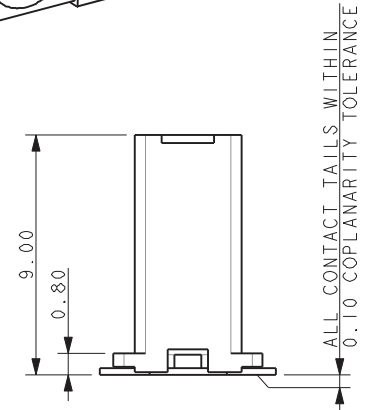
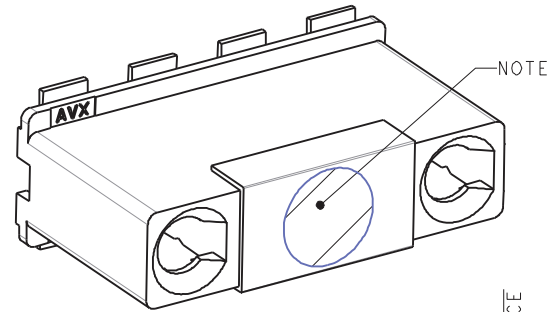
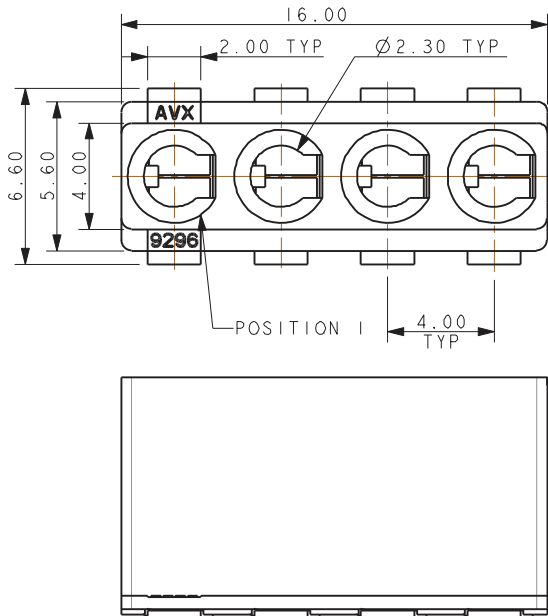

NOTES:

1. TOP MOUNT 4 WAY POKE HOME CONNECTOR. FOR FURTHER DETAILS REFER TO PRODUCT SPECIFICATION 201-01-151 AND APPLICATION NOTES 201-01-152.
2. SUITABLE FOR WIRES 18AWG TO 26AWG. MAXIMUM INSULATION 2.20MM DIAMETER.
3. INSULATOR: NYLON 46, GLASS FILLED, UL94 V-0. COLOR REFER TO PAGE 92.
4. CONTACT: TIN PLATE COPPER ALLOY.
5. PACKING IN TAPE AND REEL. QTY PER REEL 400, 330MM REEL.
6. CAPTON TAPE TO AID PICK AND PLACE, 4MM DIAMETER MAX AVAILABLE.
7. CONNECTOR OUTLINE.
8. GENERAL TOLERANCE ± 0.20 .
9. UL REFERENCE E90723.

SUGGESTED PCB LAYOUT

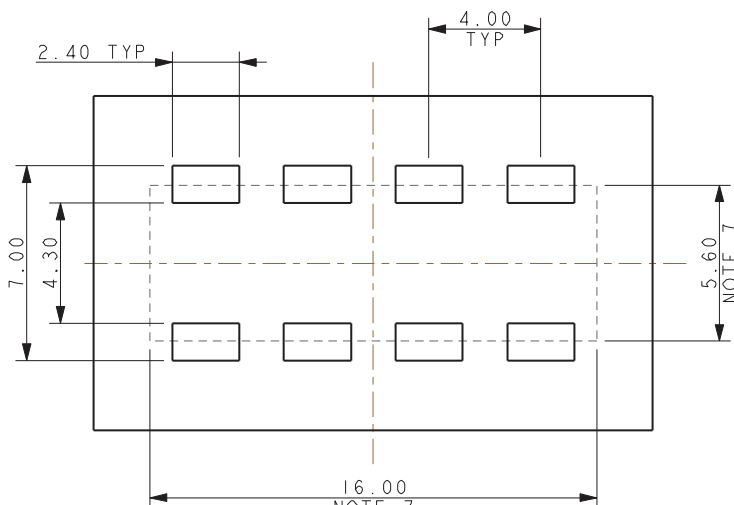

PACKING DETAILS

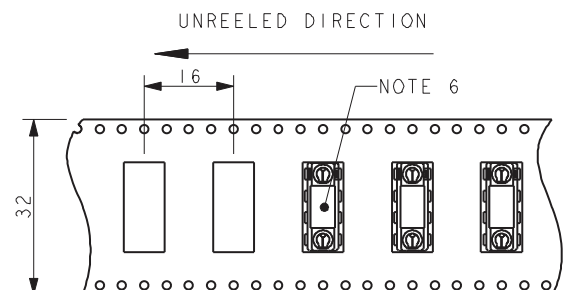
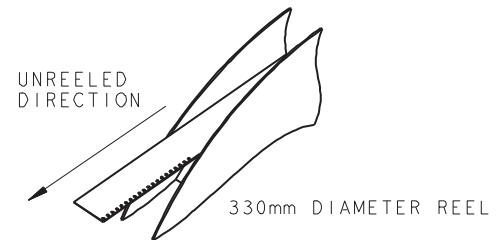

POKE-HOME: VERTICAL TOP ENTRY

18-26 AWG: 00-9296

5 Position

9296 TOP MOUNT POKE HOME CONNECTOR

5 WAY

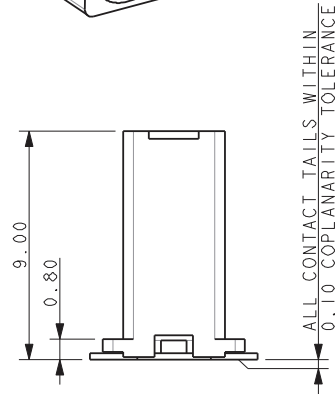
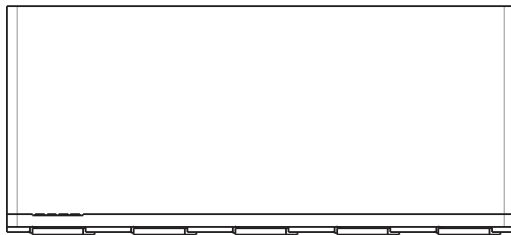
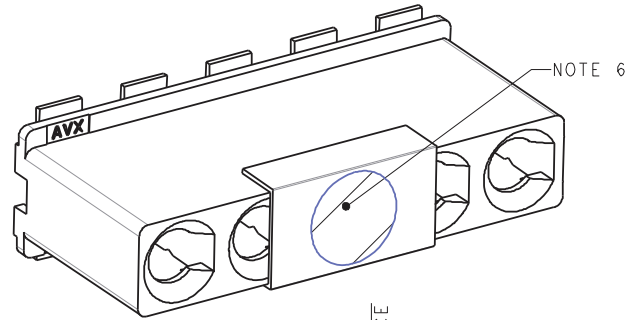
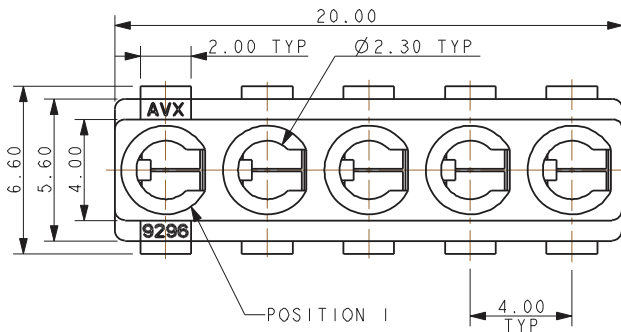

NOTES:

1. TOP MOUNT 5 WAY POKE HOME CONNECTOR. FOR FURTHER DETAILS REFER TO PRODUCT SPECIFICATION 201-01-151 AND APPLICATION NOTES 201-01-152.
2. SUITABLE FOR WIRES 18AWG TO 26AWG. MAXIMUM INSULATION 2.20MM DIAMETER.
3. INSULATOR: NYLON 46, GLASS FILLED, UL94 V-0. COLOR REFER TO PAGE 92.
4. CONTACT: TIN PLATE COPPER ALLOY.
5. PACKING IN TAPE AND REEL. QTY PER REEL 400, 330MM REEL.
6. CAPTON TAPE TO AID PICK AND PLACE, 4MM DIAMETER MAX AVAILABLE.
7. CONNECTOR OUTLINE.
8. GENERAL TOLERANCE ± 0.20 .
9. UL REFERENCE E90723.

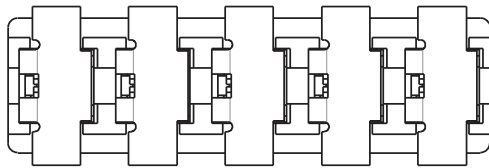

PACKING DETAILS

SUGGESTED PCB LAYOUT

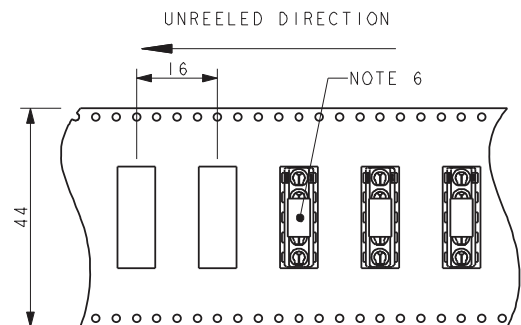
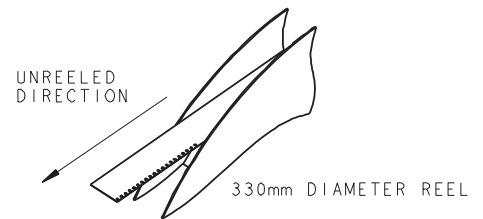
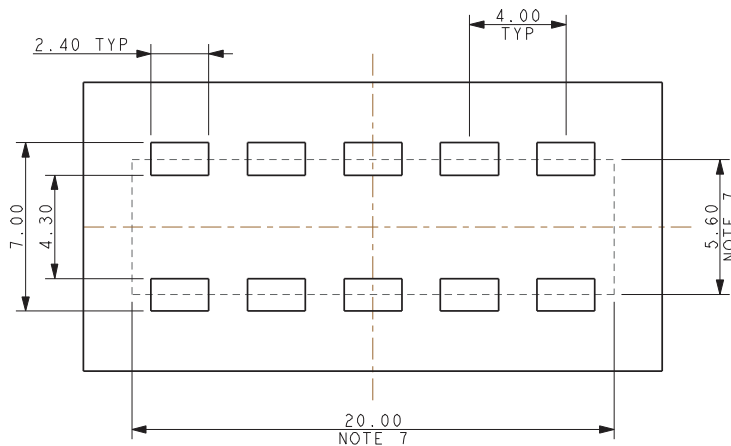

QUANTITY PER REEL 400

POKE-HOME: VERTICAL TOP ENTRY

18-26 AWG: 00-9296

6 Position

9296 TOP MOUNT POKE HOME CONNECTOR 6 WAY

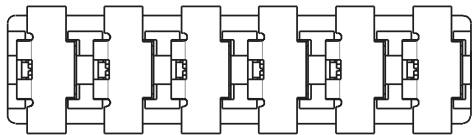
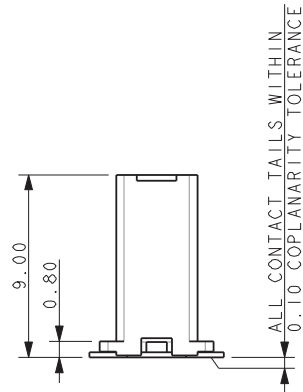
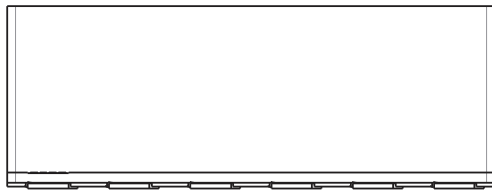
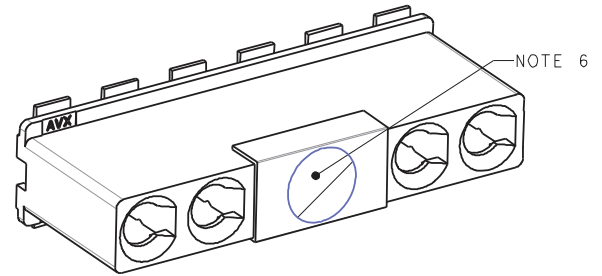
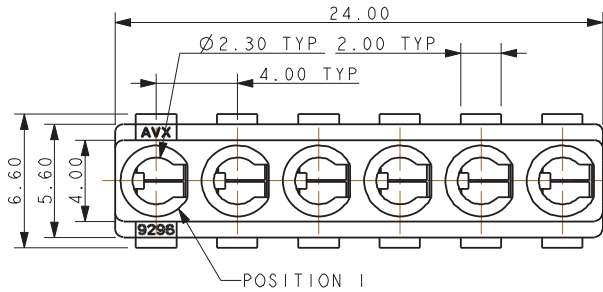

NOTES:

1. TOP MOUNT 6 WAY POKE HOME CONNECTOR. FOR FURTHER DETAILS REFER TO PRODUCT SPECIFICATION 201-01-151 AND APPLICATION NOTES 201-01-152.
2. SUITABLE FOR WIRES 18AWG TO 26AWG. MAXIMUM INSULATION 2.20MM DIAMETER.
3. INSULATOR: NYLON 46, GLASS FILLED, UL94 V-0. COLOR REFER TO PAGE 92.
4. CONTACT: TIN PLATE COPPER ALLOY.
5. PACKING IN TAPE AND REEL. QTY PER REEL 400, 330MM REEL.
6. CAPTON TAPE TO AID PICK AND PLACE, 4MM DIAMETER MAX AVAILABLE.
7. CONNECTOR OUTLINE.
8. GENERAL TOLERANCE ± 0.20 .
9. UL REFERENCE E90723.

SUGGESTED PCB LAYOUT

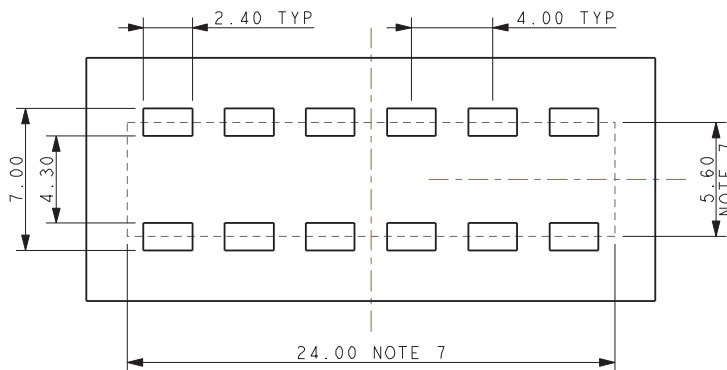

PACKING DETAILS

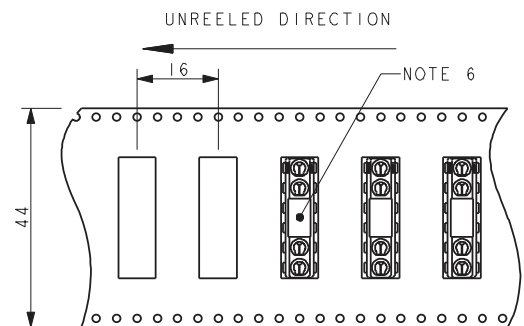
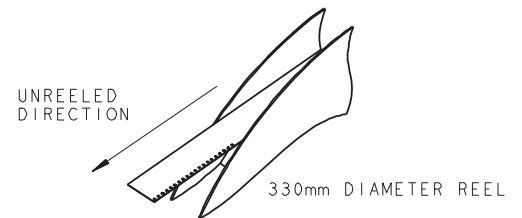

QUANTITY PER REEL 400

POKE-HOME: VERTICAL TOP ENTRY

18-26 AWG: 00-9296

Connector Assembly / Contact Opening Tool

9296 TOP MOUNT POKE HOME CONNECTOR ASSEMBLY



WIRE STRIP LENGTH

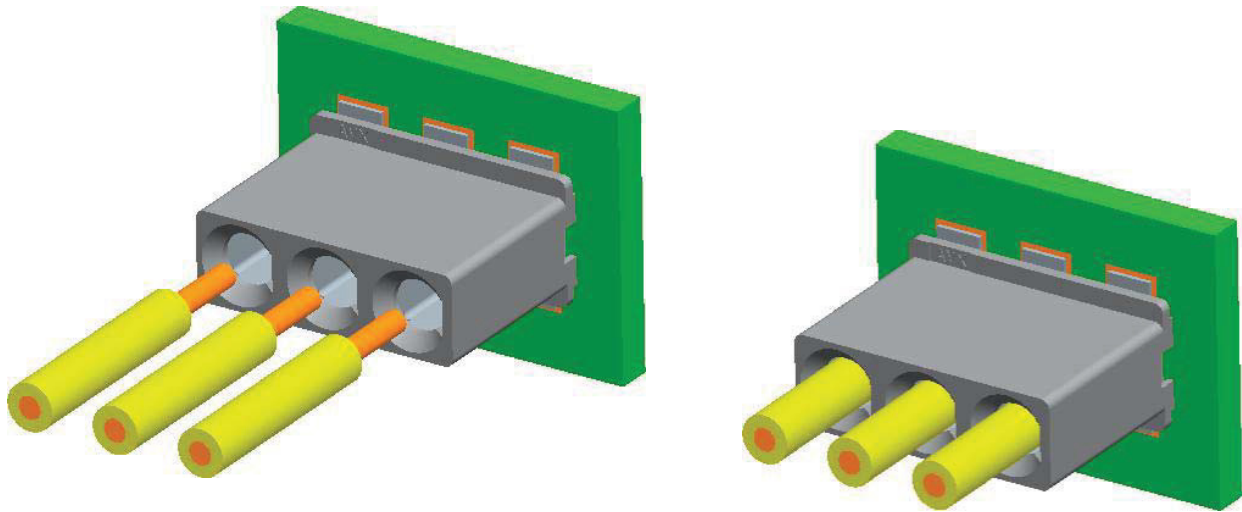

*Refer to application notes 201-01-152
for full assembly procedure.*

9296 TOP MOUNT POKE HOME CONNECTOR WIRE EXTRACTION TOOL

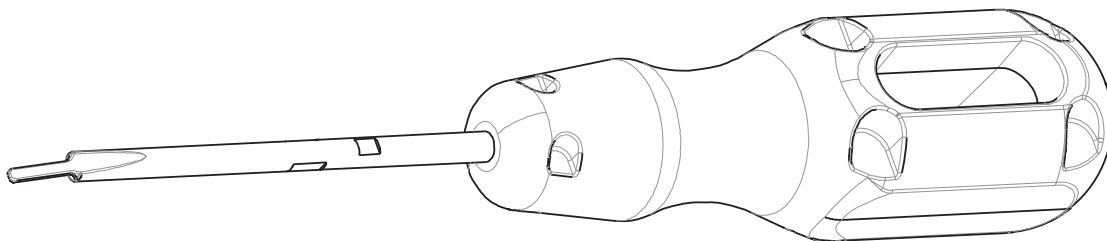

06-9296-7003-01-000

*Refer to application notes 201-01-152
for full wire extraction procedure.*

POKE-HOME: INVERTED THRU BOARD

18-26 AWG: 00-9296

General Information

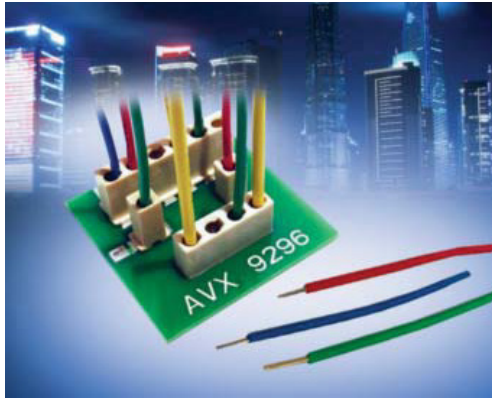

KYOCERA AVX continues to develop innovative connectors for the industrial electronics market that provide significant benefits over existing, outdated connector solutions. Listening to the design engineering community, there are ongoing applications where they cannot find an off-the-shelf solution that will satisfy a high percentage of the projects configuration, performance and cost goals.

The newest addition to KYOCERA AVX's broadening line of Wire-to-Board (WTB) connectors offers a cost effective, single Poke-Home connector solution that will meet the cost and performance targets in demanding, yet user friendly applications. At the heart of the connector is the industry proven dual tine, 3mm high spring force box contact that has been on the market as a standalone horizontal contact only solution.

The new SMT vertical through board connector allows for 18AWG to 26AWG wires to be simply stripped and inserted into the connector body at 180 degree orientation to the bottom side of the PCB with an above board height of 0.80mm. This single connector will replace existing 2-Piece WTB solutions where a header is soldered onto the PCB and a secondary crimp-to-wire receptacle assembly is plugged in. Available in 1-6 positions, each connector will accept the entire wire gauge range for either solid or stranded wires at varying current ratings supported by each wire size. Once inserted, wires can easily be removed or replaced by twisting/unscrewing or by using a small blade extraction tool.

APPLICATIONS

- Industrial/Ruggedized Wire-to-Board applications
- Replace hard soldering of wire to a PCB
- Replace costly 2-Piece header and receptacle products
- Reference Product Specification 201-01-151
- Reference Application Notes 201-01-152

FEATURES AND BENEFITS

- Dual Beam box contact provides maximum mechanical stability and wire retention
- Tape and reel packaged for automated SMT placement
- Will accept either solid or stranded wire, 18-26AWG, plated or un-plated wires
- Simple strip and insert for wire loading, with easy twist and pull for wire removal

ELECTRICAL

- Voltage Rating: 600 VAC 1 way;
300 VAC 2 - 6 way
- Current Rating: See matrix below

ENVIRONMENTAL

- Operating Temperature: -40°C to +125°C

MECHANICAL

- Contact Material: Copper Alloy
- Contact Plating: Tin over Nickel
- Durability: 5 Cycles

HOW TO ORDER

00	9296	00X
Prefix	Series	Number of Ways
		001 = 1
		002 = 2
		003 = 3
		004 = 4
		005 = 5
		006 = 6

503
Wire Gauge Size

Code	Accepted Wire Gauge	Max Insulation
503	18 - 26 AWG Solid or Stranded	2.2mm

X
Insulator Color
All Sizes
9 = UL White (Standard)
8 = UL Black (Special Order)

06
Plating Options
06 = Tin Plated



One Way Only (Special Order)
2 = UL Brown
3 = UL Blue
4 = UL Yellow
5 = UL Red
6 = UL Green
7 = UL Orange

CURRENT RATING

18AWG	20AWG	22AWG	24AWG	26AWG
7A	6A	5A	4A	3A

Certification: UL File #E90723

POKE-HOME: INVERTED THRU BOARD

18-26 AWG: 00-9296

1 Position

9296 THROUGH BOARD MOUNT POKE HOME CONNECTOR 1 WAY

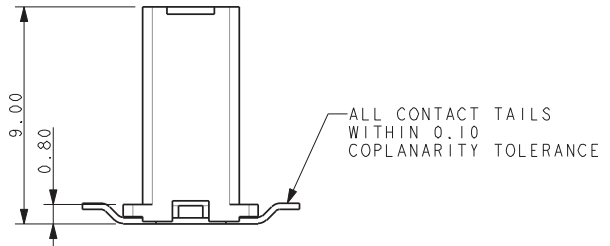
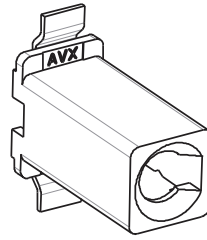
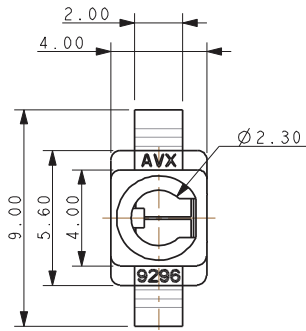

PICK AND PLACE
2.1mm DIAMETER

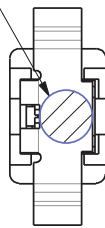

NOTES:

1. THROUGH BOARD SMT MOUNT 1 WAY POKE HOME CONNECTOR. FOR FURTHER DETAILS REFER TO PRODUCT SPECIFICATION 201-01-151 AND APPLICATION NOTES 201-01-152.
2. SUITABLE FOR WIRES 18AWG TO 26AWG. MAXIMUM INSULATION 2.20MM DIAMETER.
3. INSULATOR: NYLON 46, GLASS FILLED, UL94 V-0. COLOR REFER TO PAGE 100.
4. CONTACT: TIN PLATED COPPER ALLOY.
5. PACKING IN TAPE AND REEL, QTY. PER REEL 400, 330MM REEL.
6. GENERAL TOLERANCE ± 0.20 .
7. CLEARANCE HOLE FOR CONNECTOR.
8. UL REFERENCE E90723.

PACKING DETAILS

SUGGESTED PCB LAYOUT

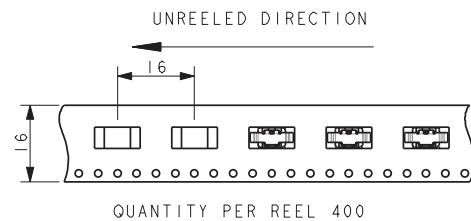
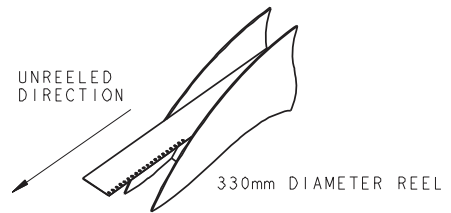
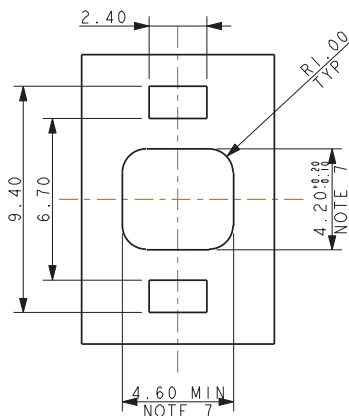

POKE-HOME: INVERTED THRU BOARD

18-26 AWG: 00-9296

2 Position

9296 THROUGH BOARD MOUNT POKE HOME CONNECTOR 2 WAY

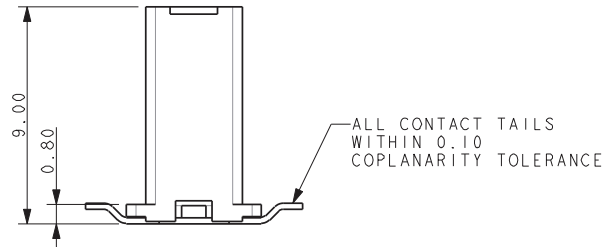
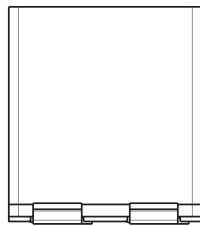
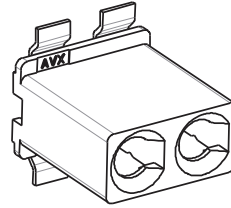
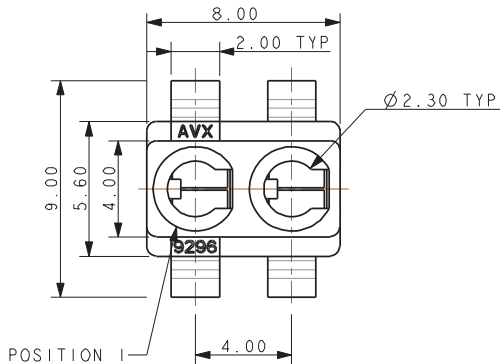

PICK AND PLACE
2.1mm DIAMETER

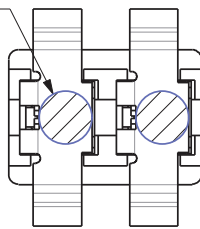

NOTES:

1. THROUGH BOARD SMT MOUNT 2 WAY POKE HOME CONNECTOR. FOR FURTHER DETAILS REFER TO PRODUCT SPECIFICATION 201-01-151 AND APPLICATION NOTES 201-01-152.
2. SUITABLE FOR WIRES 18AWG TO 26AWG. MAXIMUM INSULATION 2.20MM DIAMETER.
3. INSULATOR: NYLON 46, GLASS FILLED, UL94 V-0. COLOR REFER TO PAGE 100.
4. CONTACT: TIN PLATED COPPER ALLOY.
5. PACKING IN TAPE AND REEL, QTY. PER REEL 400, 330MM REEL.
6. GENERAL TOLERANCE ± 0.20 .
7. CLEARANCE HOLE FOR CONNECTOR.
8. UL REFERENCE E90723.

PACKING DETAILS

SUGGESTED PCB LAYOUT

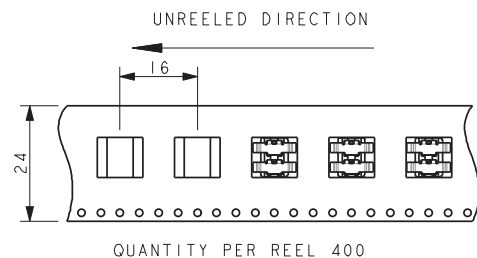
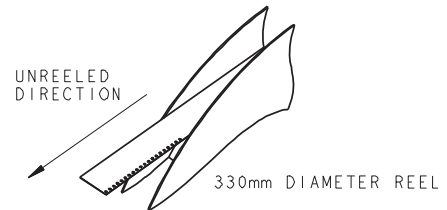
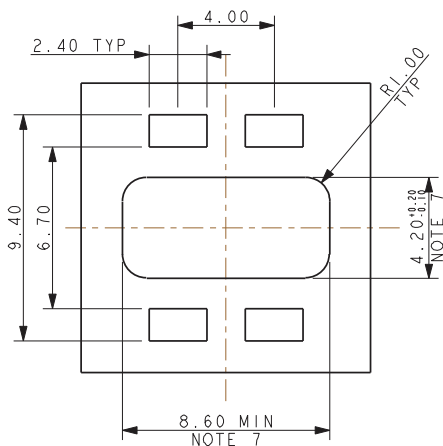

POKE-HOME: INVERTED THRU BOARD

18-26 AWG: 00-9296

3 Position

9296 THROUGH BOARD MOUNT POKE HOME CONNECTOR 3 WAY

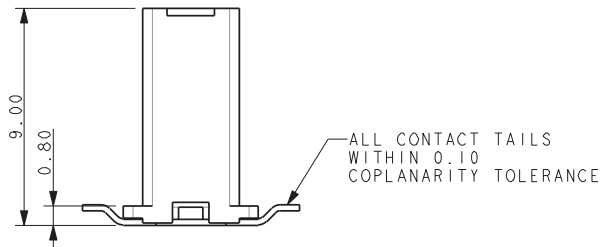
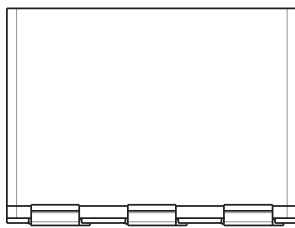
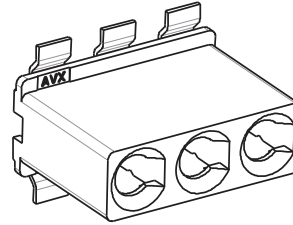
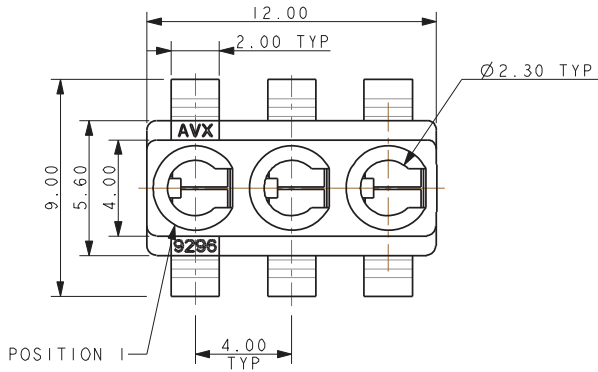

PICK AND PLACE
2.1mm DIAMETER

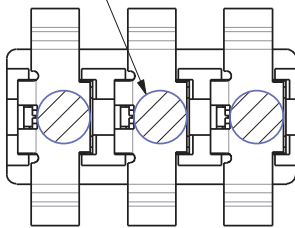

NOTES:

1. THROUGH BOARD SMT MOUNT 3 WAY POKE HOME CONNECTOR. FOR FURTHER DETAILS REFER TO PRODUCT SPECIFICATION 201-01-151 AND APPLICATION NOTES 201-01-152.
2. SUITABLE FOR WIRES 18AWG TO 26AWG. MAXIMUM INSULATION 2.20MM DIAMETER.
3. INSULATOR: NYLON 46, GLASS FILLED, UL94 V-0. COLOR REFER TO PAGE 100.
4. CONTACT: TIN PLATED COPPER ALLOY.
5. PACKING IN TAPE AND REEL, QTY. PER REEL 400, 330MM REEL.
6. GENERAL TOLERANCE ± 0.20 .
7. CLEARANCE HOLE FOR CONNECTOR.
8. UL REFERENCE E90723.

SUGGESTED PCB LAYOUT

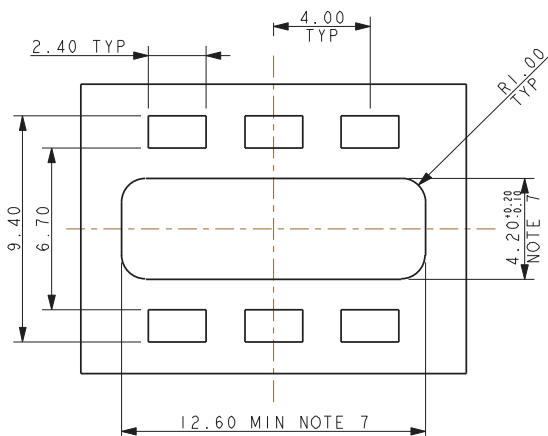

PACKING DETAILS

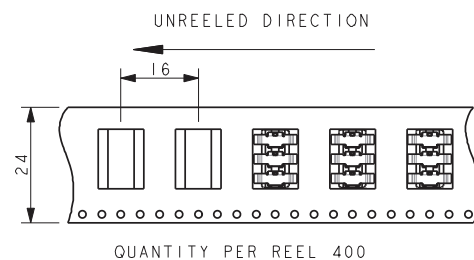
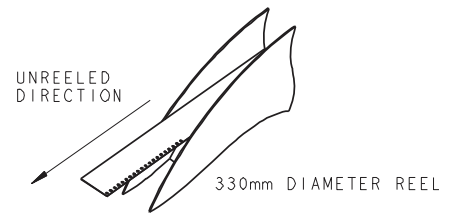

POKE-HOME: INVERTED THRU BOARD

18-26 AWG: 00-9296

4 Position

9296 THROUGH BOARD MOUNT POKE HOME CONNECTOR 4 WAY

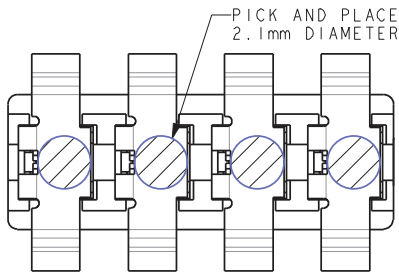
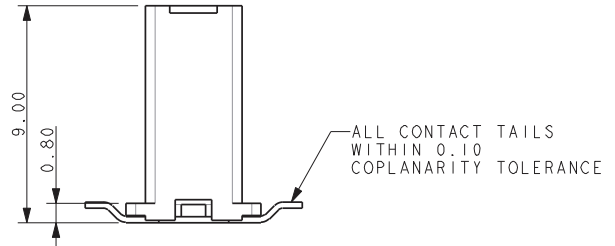
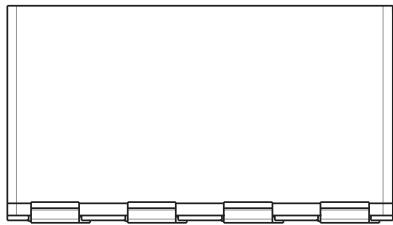
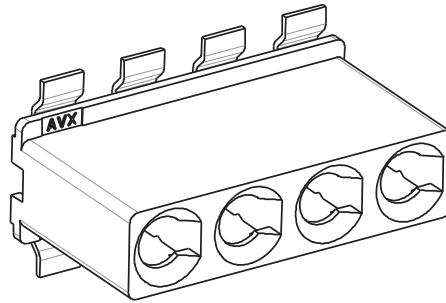
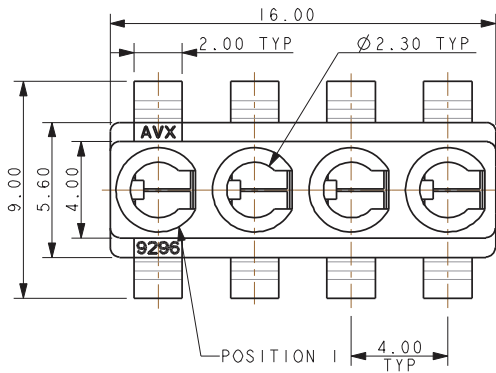

NOTES:

1. THROUGH BOARD SMT MOUNT 4 WAY POKE HOME CONNECTOR. FOR FURTHER DETAILS REFER TO PRODUCT SPECIFICATION 201-01-151 AND APPLICATION NOTES 201-01-152.
2. SUITABLE FOR WIRES 18AWG TO 26AWG. MAXIMUM INSULATION 2.20MM DIAMETER.
3. INSULATOR: NYLON 46, GLASS FILLED, UL94 V-0. COLOR REFER TO PAGE 100.
4. CONTACT: TIN PLATED COPPER ALLOY.
5. PACKING IN TAPE AND REEL, QTY. PER REEL 400, 330MM REEL.
6. GENERAL TOLERANCE ± 0.20 .
7. CLEARANCE HOLE FOR CONNECTOR.
8. UL REFERENCE E90723.

PACKING DETAILS

SUGGESTED PCB LAYOUT

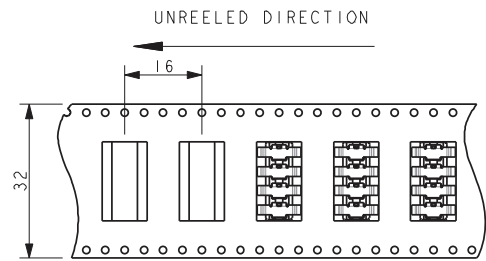
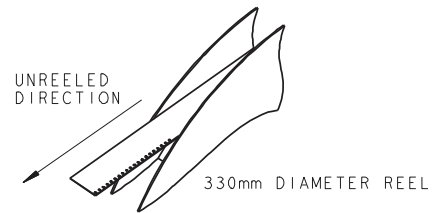
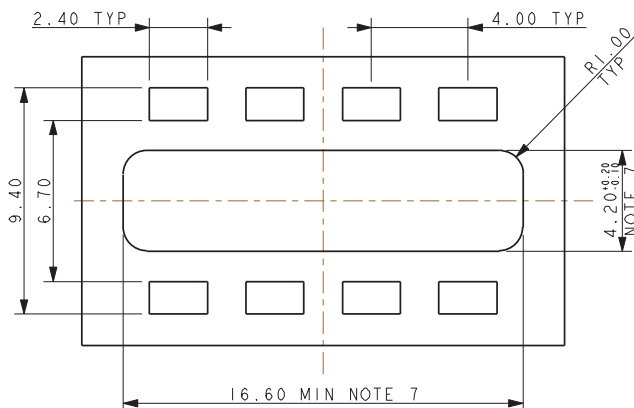

POKE-HOME: INVERTED THRU BOARD

18-26 AWG: 00-9296

5 Position

9296 THROUGH BOARD MOUNT POKE HOME CONNECTOR 5 WAY

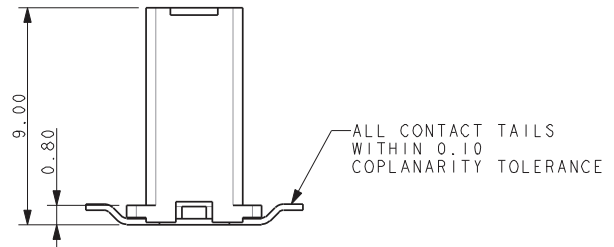
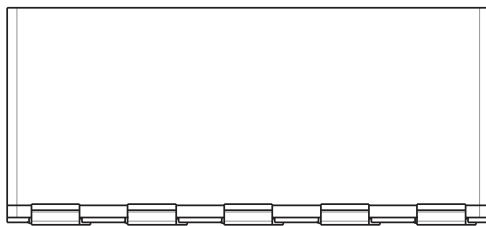
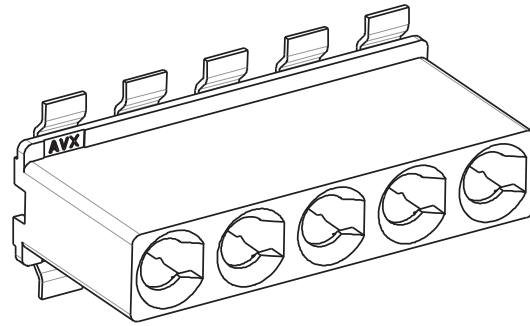
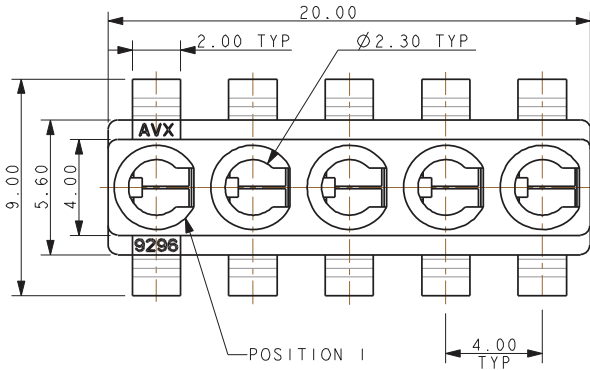

PICK AND PLACE
2.1mm DIAMETER

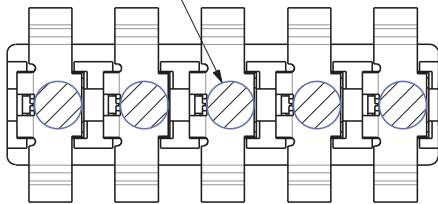

NOTES:

1. THROUGH BOARD SMT MOUNT 5 WAY POKE HOME CONNECTOR. FOR FURTHER DETAILS REFER TO PRODUCT SPECIFICATION 201-01-151 AND APPLICATION NOTES 201-01-152.
2. SUITABLE FOR WIRES 18AWG TO 26AWG. MAXIMUM INSULATION 2.20MM DIAMETER.
3. INSULATOR: NYLON 46, GLASS FILLED, UL94 V-0. COLOR REFER TO PAGE 100.
4. CONTACT: TIN PLATED COPPER ALLOY.
5. PACKING IN TAPE AND REEL, QTY. PER REEL 400, 330MM REEL.
6. GENERAL TOLERANCE ± 0.20 .
7. CLEARANCE HOLE FOR CONNECTOR.
8. UL REFERENCE E90723.

SUGGESTED PCB LAYOUT

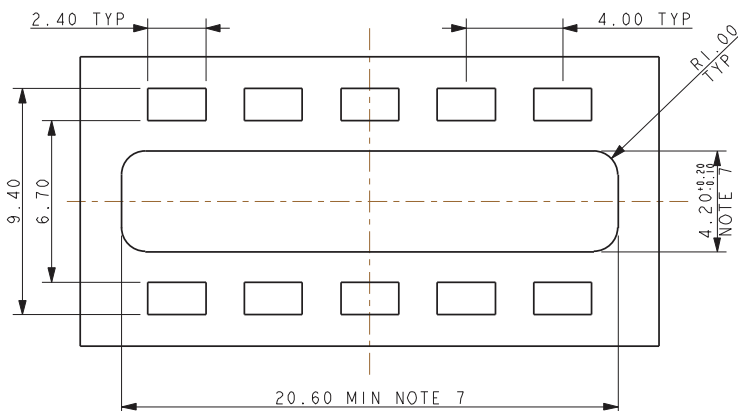

PACKING DETAILS

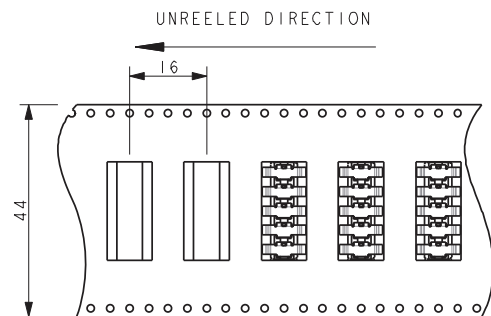
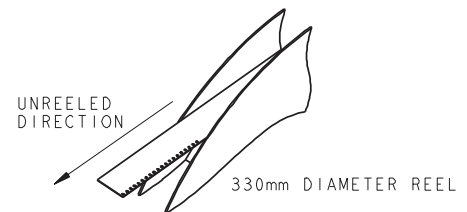

QUANTITY PER REEL 400

POKE-HOME: INVERTED THRU BOARD

18-26 AWG: 00-9296

6 Position

9296 THROUGH BOARD MOUNT POKE HOME CONNECTOR 6 WAY

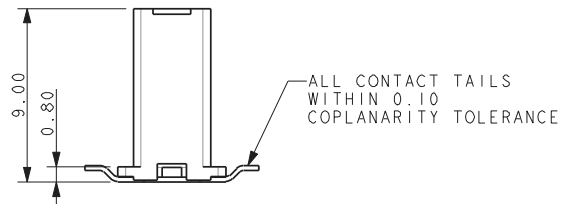
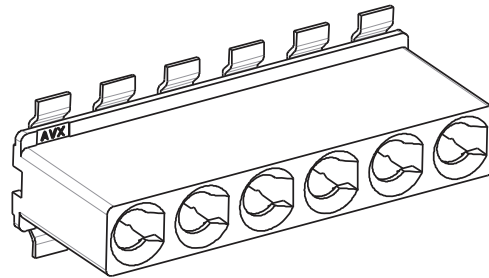
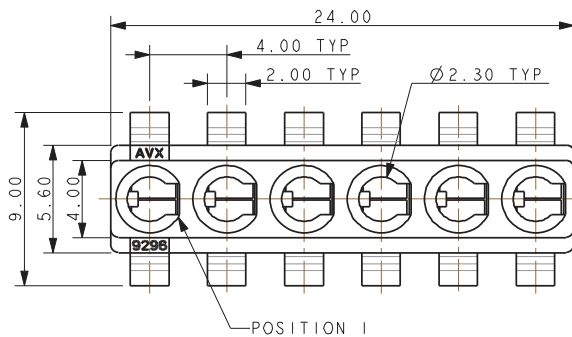

NOTES:

1. THROUGH BOARD SMT MOUNT 6 WAY POKE HOME CONNECTOR. FOR FURTHER DETAILS REFER TO PRODUCT SPECIFICATION 201-01-151 AND APPLICATION NOTES 201-01-152.
2. SUITABLE FOR WIRES 18AWG TO 26AWG. MAXIMUM INSULATION 2.20MM DIAMETER.
3. INSULATOR: NYLON 46, GLASS FILLED, UL94 V-0. COLOR REFER TO PAGE 100.
4. CONTACT: TIN PLATED COPPER ALLOY.
5. PACKING IN TAPE AND REEL, QTY. PER REEL 400, 330MM REEL.
6. GENERAL TOLERANCE ± 0.20 .
7. CLEARANCE HOLE FOR CONNECTOR.
8. UL REFERENCE E90723.

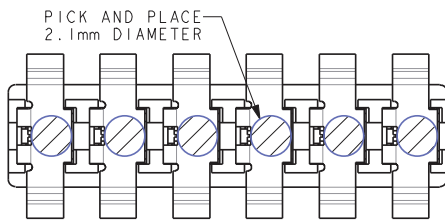

SUGGESTED PCB LAYOUT

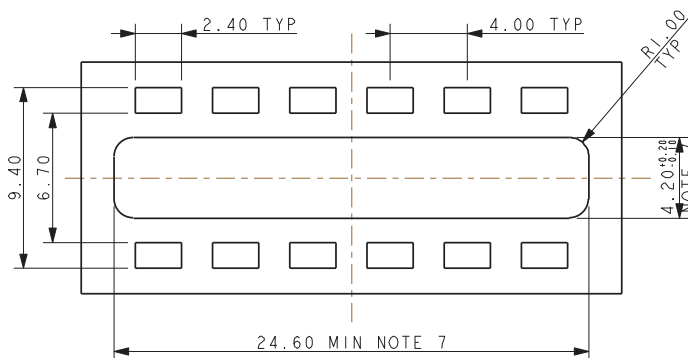

PACKING DETAILS

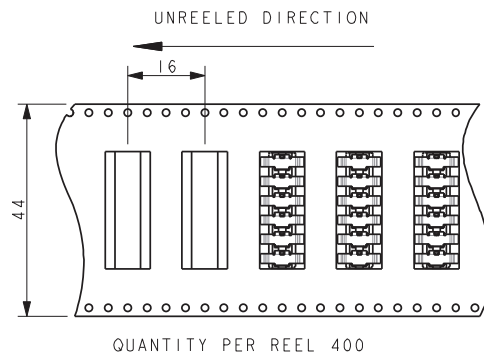
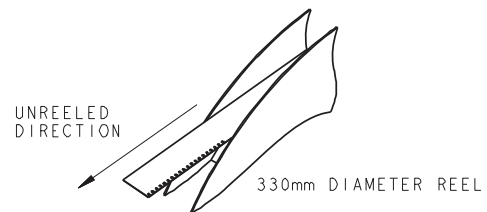

POKE-HOME: INVERTED THRU BOARD

18-26 AWG: 00-9296

Wire Strip Length

9296 THROUGH BOARD MOUNT POKE HOME CONNECTOR ASSEMBLY

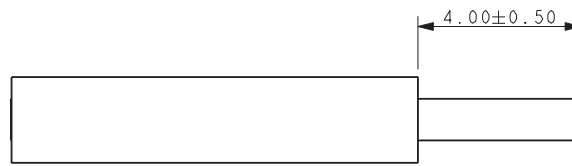

WIRE STRIP LENGTH

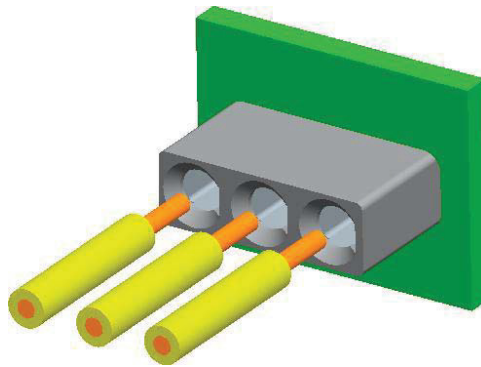

*Refer to application notes 201-01-152
for full assembly procedure.*

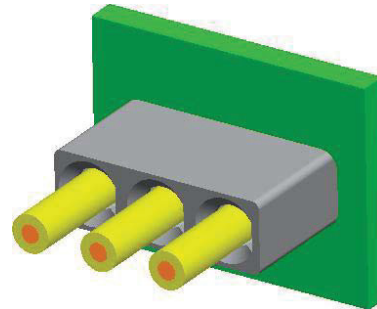
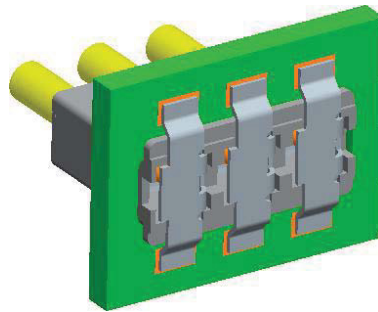

THROUGH BOARD MOUNT POKE HOME CONNECTOR WIRE EXTRACTION TOOL

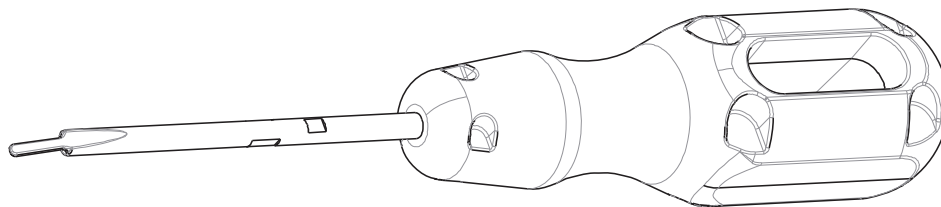

06-9296-7003-01-000 – PLASTIC TOOL
06-9296-7004-03-000 – METAL TOOL

Refer to application notes 201-01-152 for full wire extraction procedure.

SINGLE VERTICAL TOP ENTRY

18 AWG: 58-9296

General Information

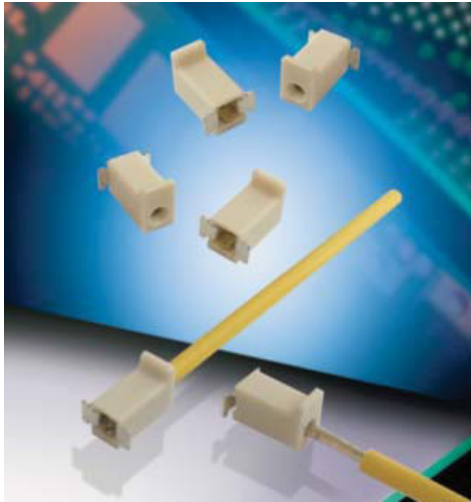

Vertical poke-home connectors were introduced into the market a few years ago to provide a reliable, yet cost effective discrete wire-to-board termination in perpendicular applications. Designed to bridge the gap between inconsistent hand soldering of wires and costly 2-piece connector systems, these connectors are available in a range of positions and configurations while accepting 18 to 26AWG solid or stranded wires.

This latest connector was developed specifically to support the high volume 18AWG wire applications used in power supply, LED driver and industrial control products where PCB space is limited. This new 9296 connector offers a robust single beam contact which securely captures and retains the wire in a 23% smaller package size.

APPLICATIONS

- Replace inconsistent hand soldered perpendicular wire terminations onto PCB's in:
 - Power Supplies
 - LED Drivers
 - Industrial/Motor Controls
- Offer a simple and cost reduced solution to existing 2-Piece connector systems

FEATURES AND BENEFITS

- Pre-Plated phosphor bronze contact material provides excellent spring performance with high fatigue and corrosion resistance
- The single stamped and formed box contact maximizes board attachment and wire capture strength
- Tight tolerance and wire insulation stop helps to prevent potting from flowing into the connector during encapsulation processes
- Integral molded in flange provides a generous vacuum pick-up point for automated SMT placement

ELECTRICAL

- Current Rating: 8 Amps
- Voltage Rating: 600 VAC

ENVIRONMENTAL

- Operating Temperature: -40°C to +125°C

MECHANICAL

- Insulator Material: Glass-Filled Nylon 46, UL94V0
- Contact Material: Phosphor Bronze
- Plating: Pure Tin
- Durability: 3 Cycles

HOW TO ORDER

589296001000014



SINGLE VERTICAL TOP ENTRY

18 AWG: 58-9296

Single Vertical Top Entry

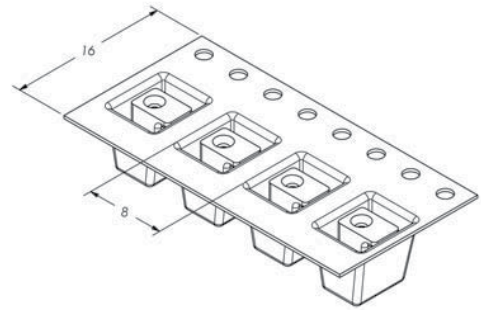
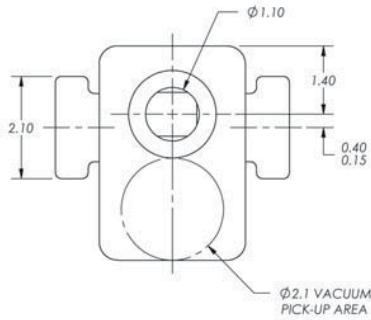
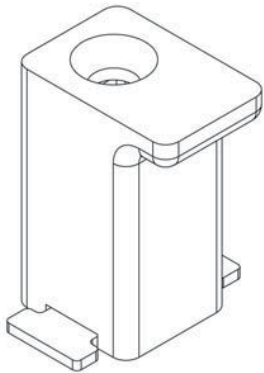

PARTS IN POCKET TAPE
SCALE 2.5:1

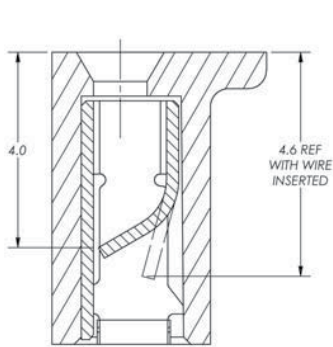

SECTION X-X

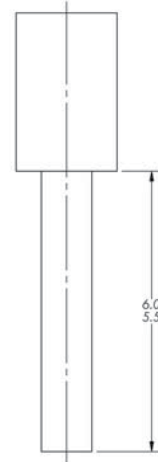
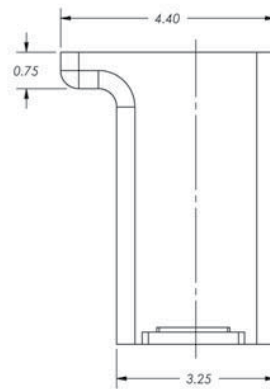
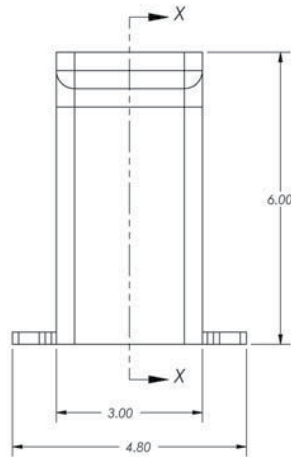

RECOMMENDED
WIRE STRIP DETAIL

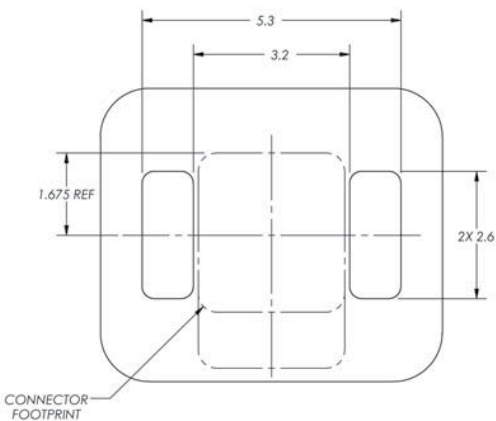

RECOMMENDED PCB LAYOUT

NOTES:

1. HOUSING MATERIAL: GLASS-FILLED, HIGH TEMP. THERMOPLASTIC; UL94V-0; COLOR: NATURAL.
2. CONTACT MATERIAL: HIGH STRENGTH PHOSPHOR BRONZE ALLOY; PRE-PLATED LEAD-FREE TIN OVER NICKEL PLATING.
3. PACKAGING: POCKET TAPE ON REELS; 1,250 PARTS PER REEL.

STANDARD VERTICAL TOP ENTRY 18-22AWG

00-9296



GENERAL DESCRIPTION

Vertical poke-home connectors were introduced into the market several years ago to provide a reliable, yet cost effective discrete wire-to-board termination in perpendicular applications. These were designed to bridge the gap between inconsistent and challenging hand soldering of wires and costly 2-piece connector systems in low pin count applications. This latest connector was developed specifically to support 18 to 22AWG solid or stranded wire terminations used in power supply, LED driver and industrial control products where PCB space is limited. This new 9296 connector offers a robust single beam contact which securely captures and retains the wire in a 23% smaller package size over previous versions.

APPLICATIONS

- Replace inconsistent hand soldered perpendicular wire terminations onto PCB's in:
 - ▶ Power Supplies
 - ▶ LED Drivers
 - ▶ Industrial/Motor Controls
- Offer a simple and cost reduced solution to existing 2-Piece connector systems

ELECTRICAL

- Current Rating: See Below
- Voltage Rating: 600 VAC

ENVIRONMENTAL

- Operating Temperature: -40°C to +130°C

FEATURES AND BENEFITS

- Pre-Plated phosphor bronze contact material provides excellent spring performance with high fatigue and corrosion resistance
- The single stamped and formed box contact maximizes board attachment and wire capture strength
- Integral molded in flange provides a generous vacuum pick-up point for automated SMT placement
- UL approved color range to match individual wires for easy and accurate final product assembly

MECHANICAL

- Insulator Material: Glass-Filled Nylon 46: UL94V0
- Contact Material: Phosphor Bronze
- Plating: Lead-Free Tin Over Nickel
- Durability: 3 Cycles

HOW TO ORDER

00	9296	001	603	X	06	
Prefix Wire to Board Connector	Series	No. of Ways	Description 603 = 18-22AWG Solid or Stranded	Plating 2 = Brown 3 = Blue 4 = Yellow 5 = Red 6 = Green 7 = Orange 8 = Black 9 = White	Plating 006 = Tin Plated	

CURRENT RATING

18AWG	20AWG	22AWG
8A	7A	6A

Certification: UL File #E90723

STANDARD VERTICAL TOP ENTRY 18-22AWG

00-9296

PARTS IN POCKET TAPE SCALE 2:1

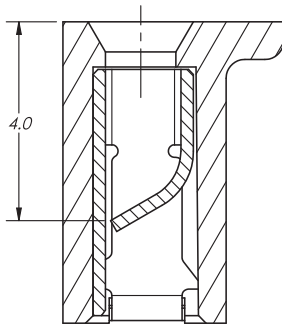
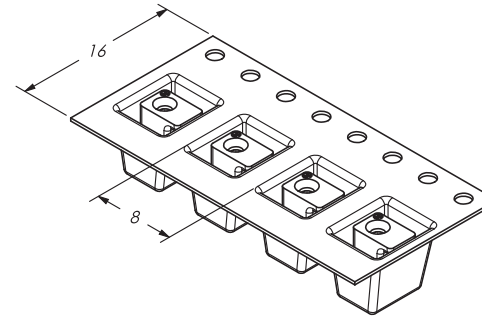
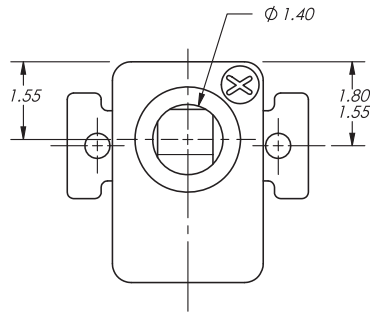
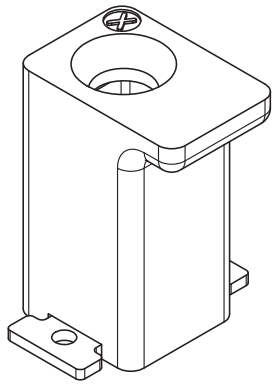

SECTION ON X-X

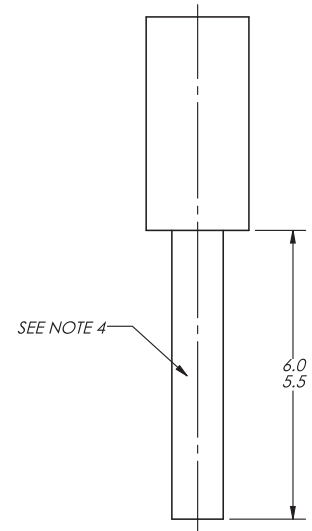
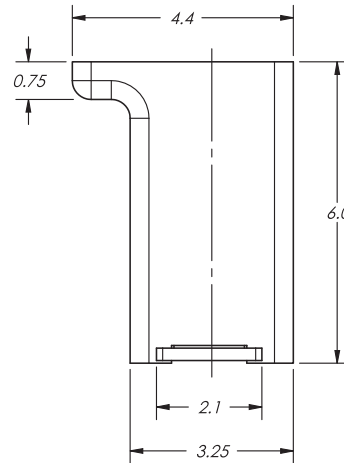
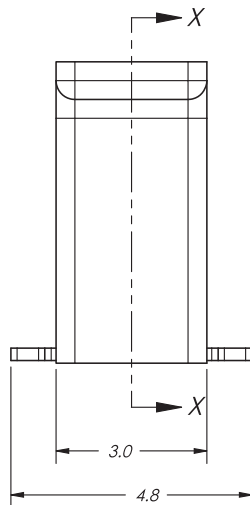

RECOMMENDED WIRE STRIP DETAIL

RECOMMENDED PCB LAYOUT

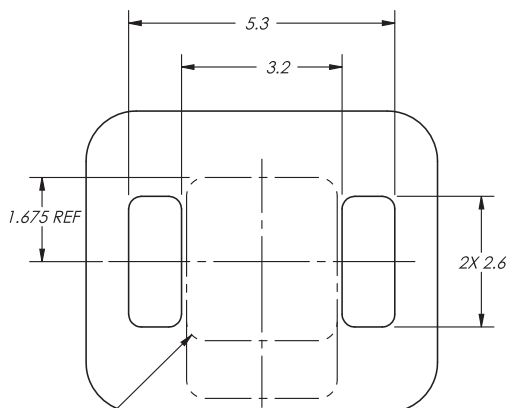

CONNECTOR FOOTPRINT

NOTES:

1. HOUSING MATERIAL: GLASS-FILLED, HIGH TEMP. THERMOPLASTIC; UL94V-0; COLOR: SEE PAGE 1.
2. CONTACT MATERIAL: HIGH STRENGTH PHOSPHOR BRONZE ALLOY; PRE-PLATED LEAD-FREE TIN OVER NICKEL PLATING.
3. PACKAGING: POCKET TAPE ON REELS; 1,250 PARTS PER REEL.
4. STRANDED WIRE MUST BE SUFFICIENTLY TWISTED OR TIN DIPPED FOR PROPER INSERTION.

POKE-HOME: SINGLE VERTICAL CONTACT

18-24 AWG: 70-9296

General Information



KYOCERA AVX continues to develop innovative connectors for the industrial electronics market that provide significant benefits over existing, outdated connector solutions. The latest release is single vertical Wire-to-Board (WTB) contacts that provide cost effective, yet robust discrete wire termination without the expense of an insulator and assembly costs. This new family of top and bottom entry contacts compliments the existing vertical poke home connectors already on the market, providing a lower cost solution without jeopardizing performance.

The new contacts support both solid and stranded wires ranging from 24AWG down to 18AWG and current ratings as high as 12 amps. The set of four contacts provide both top and bottom entry for FR4 and metal core printed circuit boards.

APPLICATIONS

- Machine Controls: motors, drives, solenoids, sensors, fans and pumps
- Commercial Buildings: controls, security, fire and sensors
- Smart Grid: meters, breakers and panels
- SSL/LED; bulbs, fixtures, signage and streetlights

FEATURES AND BENEFITS

- Dual Beam contact provides maximum mechanical stability and wire retention
- Tape and reel packaged for automated SMT placement
- Staged current rating based on AWG, maximum is 12A (18AWG)
- Increased functionality with the single contact placement: multiple contacts and/or specific individual locations

ELECTRICAL

- Voltage Rating: 300V
Based on placement distance
- Current Rating: See matrix below

ENVIRONMENTAL

- Operating Temperature:
-40°C to +125°C

MECHANICAL

- Contact Material: Phosphor Bronze
- Contact Plating: Pure Tin
- Durability: 5 Cycles

HOW TO ORDER

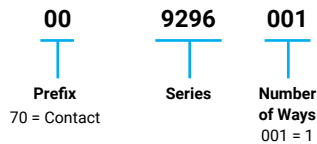

Code	Contact Location	Wire Insertion Direction	Recommended For Board Type	Wire Gauges
103	Top Side	Bottom Entry	FR4	18 - 24 AWG
113	Through Board	Top Entry	FR4	18 - 24 AWG
123	Top Side	Bottom Entry	Metal Clad	18 - 24 AWG
133	Through Board	Top Entry	Metal Clad	18 - 24 AWG



CURRENT RATING

18AWG	20AWG	22AWG	24AWG
15A	14A	10A	9A

Certification: UL File #E90723

POKE-HOME: SINGLE VERTICAL CONTACT

18-24 AWG: 70-9296

Top Side Contact - Bottom Entry Wire (FR4 Board)

70-9296-001-103-006

9296 VERTICAL MOUNT SMT CONTACT

TOP SIDE CONTACT – BOTTOM ENTRY WIRE (FR4 BOARD)

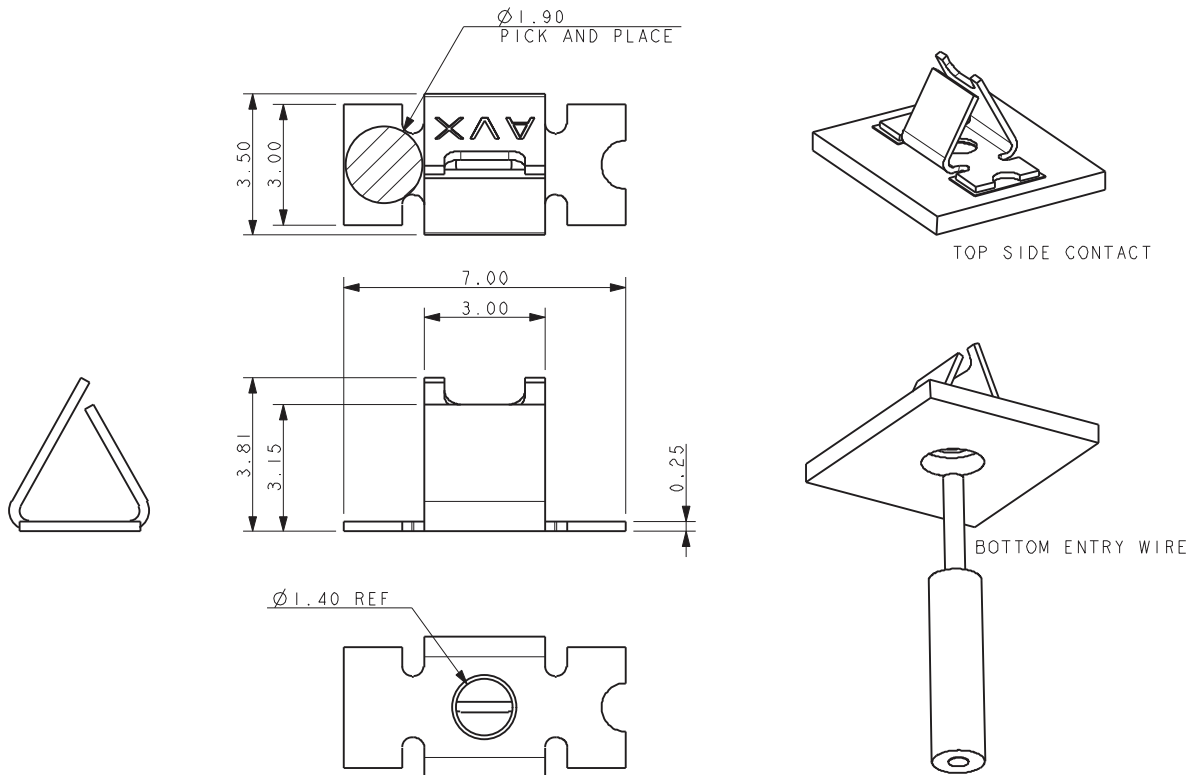

SUGGESTED PCB LAYOUT

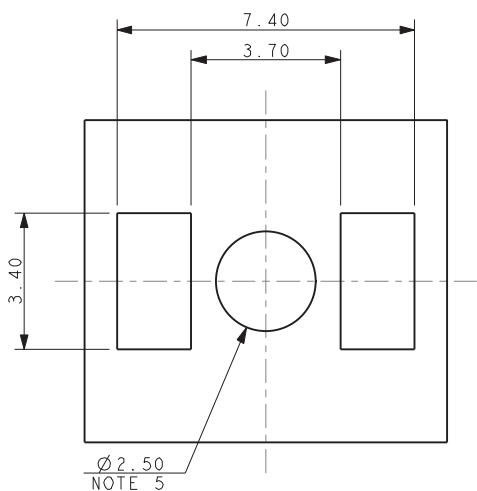

NOTES:

- CONTACT MOUNTS ON TOP SIDE OF BOARD, WIRE INSERTED FROM UNDERSIDE OF BOARD.
- STYLE RECOMMENDED FOR FR4 BOARDS WHERE MINIMUM CLEARANCE REQUIRED TO CONTACT AND MOUNTING PADS.
- FOR FURTHER INFORMATION REFER TO ELCO SPECIFICATION 201-01-161 AND APPLICATION NOTES 201-01-175.
- MATERIAL: TIN PLATED PHOSPHOR BRONZE.
- HOLE FOR WIRE INSERTION.
- PACING IN TAPE AND REEL, 2000 PIECES PER REEL.
- FOR WIRE TRIM DETAILS REFER TO PAGE 115.
- UL REFERENCE E90723.
- GENERAL TOLERANCE ± 0.10 .

PACKING DETAILS

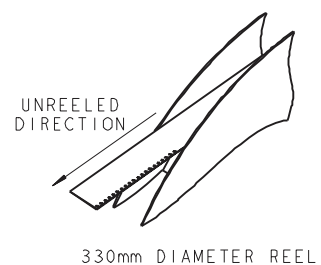
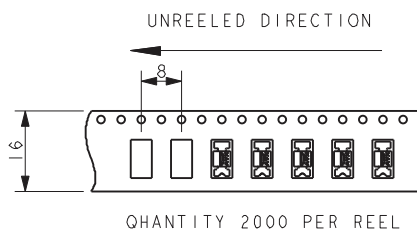

POKE-HOME: SINGLE VERTICAL CONTACT

18-24 AWG: 70-9296

Through Board Contact - Top Entry Wire (FR4 Board)

70-9296-001-113-006

9296 VERTICAL MOUNT SMT CONTACT

THROUGH BOARD CONTACT – TOP ENTRY WIRE (FR4 BOARD)

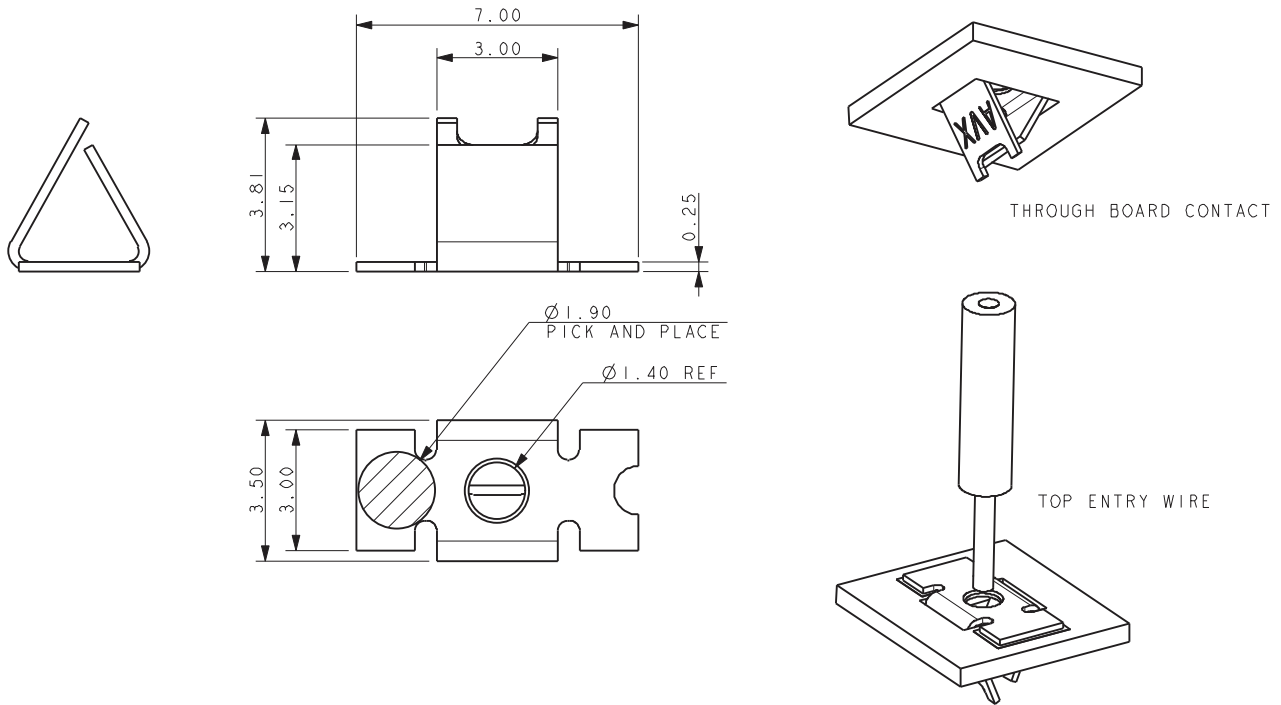

SUGGESTED PCB LAYOUT

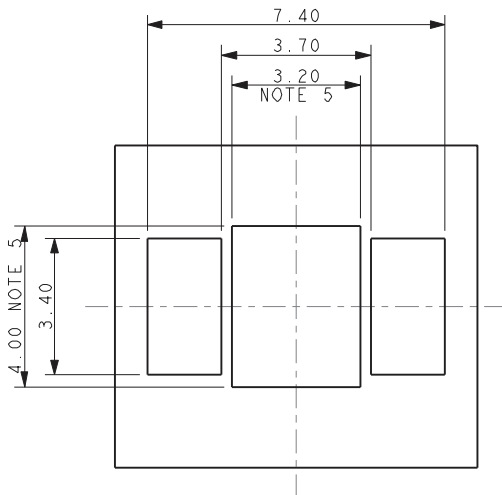

NOTES:

1. CONTACT MOUNTS THROUGH THE BOARD, WIRE INSERTED FROM TOP SIDE
2. OF BOARD.
3. STYLE RECOMMENDED FOR FR4 BOARDS WHERE MINIMUM CLEARANCE REQUIRED TO CONTACT AND MOUNTING PADS.
4. FOR FURTHER INFORMATION REFER TO ELCO SPECIFICATION 201-01-161 AND APPLICATION NOTES 201-01-175.
5. MATERIAL: TIN PLATED PHOSPHOR BRONZE.
6. HOLE DIMENSIONS FOR CONTACT.
7. PACING IN TAPE AND REEL, 2000 PIECES PER REEL.
8. FOR WIRE TRIM DETAILS REFER TO PAGE 115.
9. UL REFERENCE E90723.
10. GENERAL TOLERANCE ± 0.10 .

PACKING DETAILS

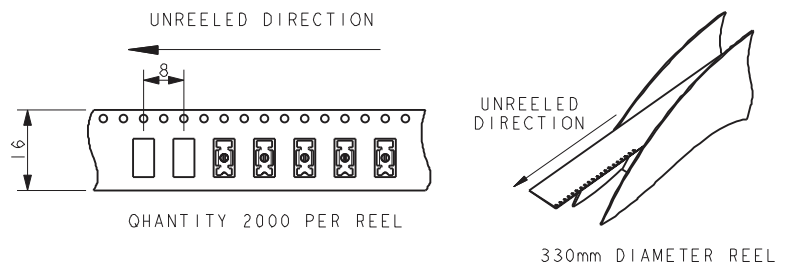

POKE-HOME: SINGLE VERTICAL CONTACT

18-24 AWG: 70-9296

Top Side Contact - Bottom Entry Wire (Metal Board)

70-9296-001-123-006

9296 VERTICAL MOUNT SMT CONTACT

TOP SIDE CONTACT – BOTTOM ENTRY WIRE (METAL BOARD)

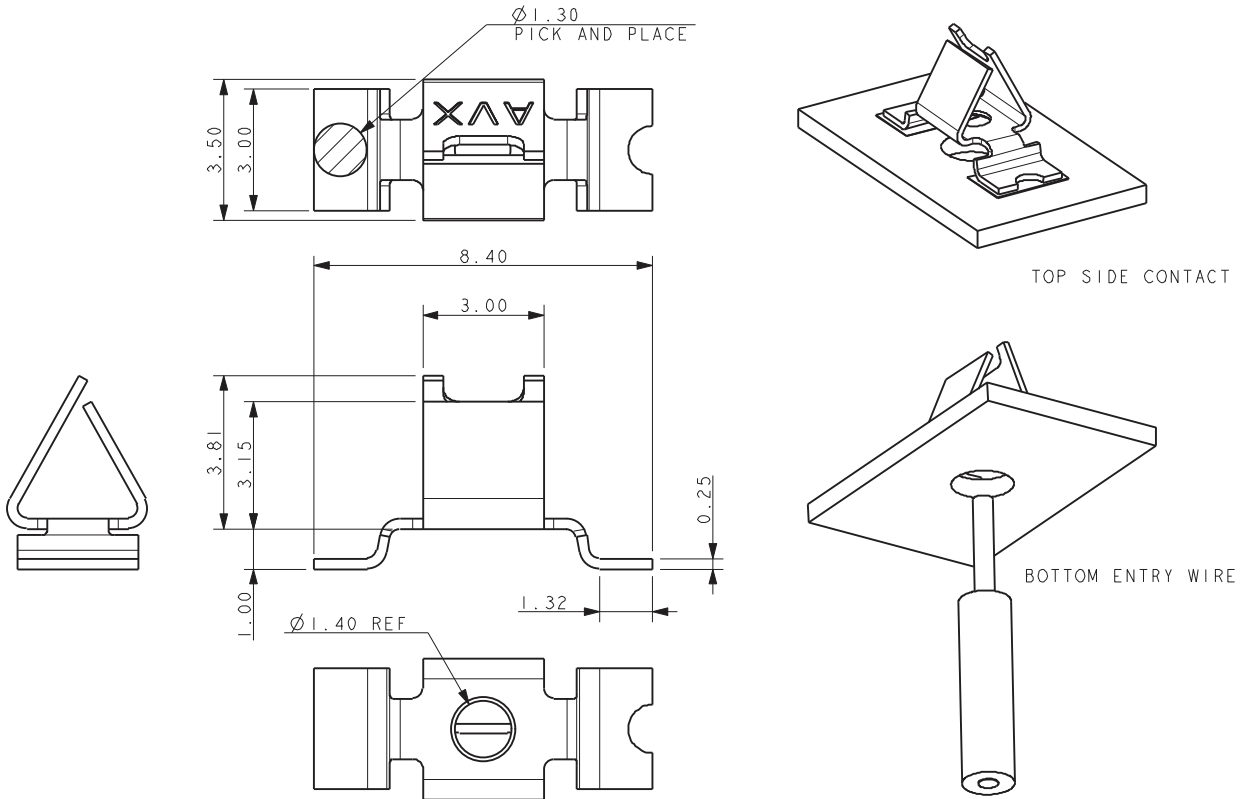

SUGGESTED PCB LAYOUT

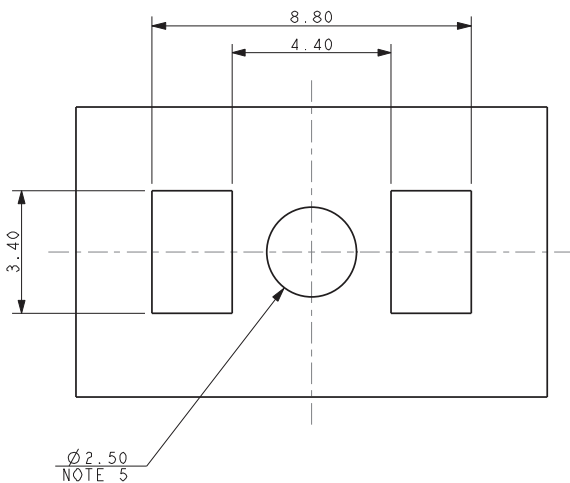

NOTES:

- CONTACT MOUNTS ON TOP SIDE OF BOARD, WIRE INSERTED FROM UNDERSIDE OF BOARD.
- STYLE RECOMMENDED FOR METAL CLAD BOARDS WHERE MAXIMUM CLEARANCE REQUIRED TO CONTACT AND MOUNTING PADS.
- FOR FURTHER INFORMATION REFER TO ELCO SPECIFICATION 201-01-161 AND APPLICATION NOTES 201-01-175.
- MATERIAL: TIN PLATED PHOSPHOR BRONZE.
- HOLE FOR WIRE INSERTION.
- PACING IN TAPE AND REEL, 1600 PIECES PER REEL.
- FOR WIRE TRIM DETAILS REFER TO PAGE 115.
- UL REFERENCE E90723.
- GENERAL TOLERANCE ± 0.10 .

PACKING DETAILS

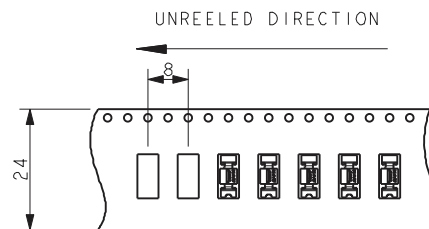

QUANTITY 1600 PER REEL

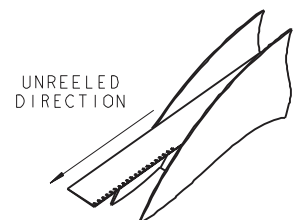

330mm DIAMETER REEL

POKE-HOME: SINGLE VERTICAL CONTACT

18-24 AWG: 70-9296

Through Board Contact - Top Entry Wire (Metal Board)

70-9296-001-133-006

9296 VERTICAL MOUNT SMT CONTACT

THROUGH BOARD CONTACT – TOP ENTRY WIRE (METAL BOARD)

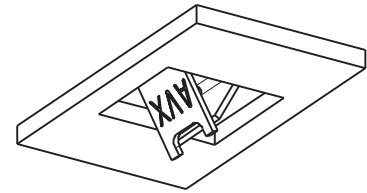
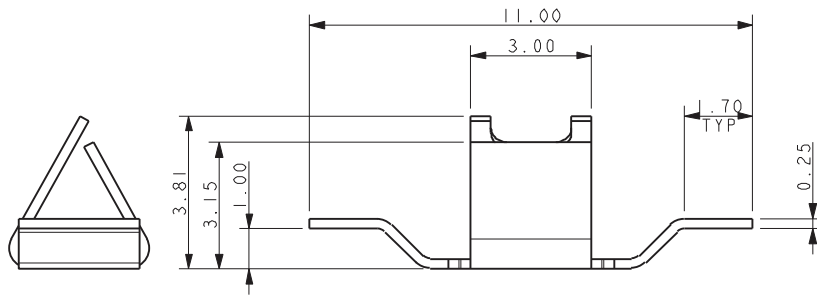

THROUGH BOARD CONTACT

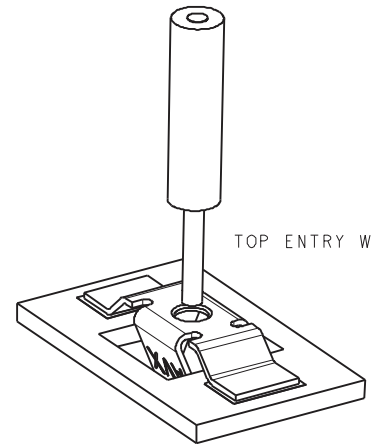
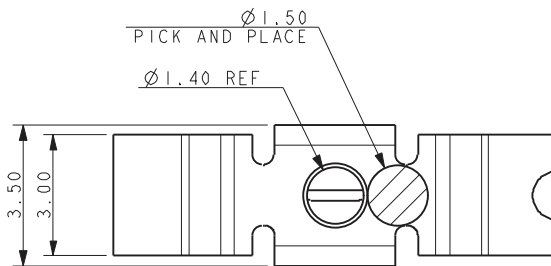

TOP ENTRY WIRE

SUGGESTED PCB LAYOUT

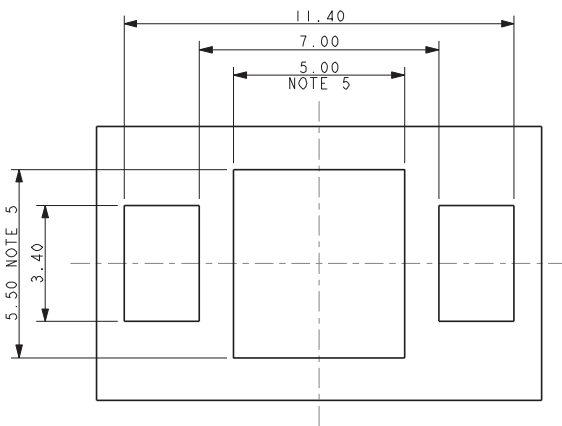

NOTES:

- CONTACT MOUNTS THROUGH THE BOARD, WIRE INSERTED FROM TOP SIDE OF BOARD.
- STYLE RECOMMENDED FOR METAL CLAD BOARDS WHERE ADDITIONAL CLEARANCE REQUIRED TO CONTACT AND MOUNTING PADS.
- FOR FURTHER INFORMATION REFER TO ELCO SPECIFICATION 201-01-161 AND APPLICATION NOTES 201-01-175.
- MATERIAL: TIN PLATED PHOSPHOR BRONZE.
- HOLE DIMENSIONS FOR CONTACT.
- PACING IN TAPE AND REEL, 2000 PIECES PER REEL.
- FOR WIRE TRIM DETAILS REFER TO PAGE 115.
- UL REFERENCE E90723.
- GENERAL TOLERANCE ± 0.10 .

PACKING DETAILS

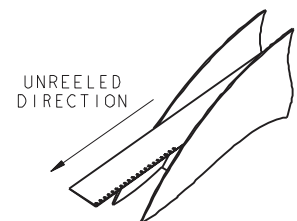
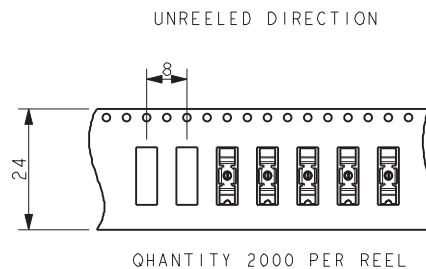

330mm DIAMETER REEL

POKE-HOME: SINGLE VERTICAL CONTACT

18-24 AWG: 70-9296

Wire Trim Details

9296 VERTICAL MOUNT SMT CONTACT WIRE TRIM DETAILS

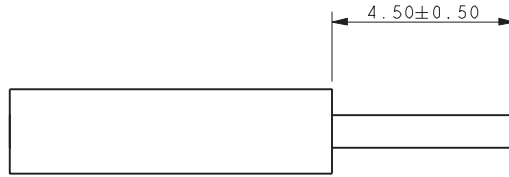

WIRE STRIP LENGTH, ALL STYLES

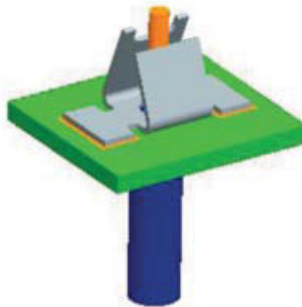

70-9296-001-103-006



70-9296-001-113-006

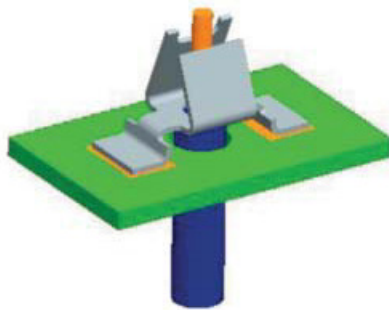

70-9296-001-123-006

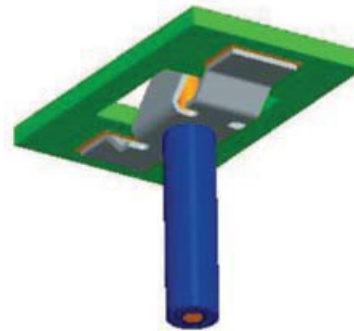

70-9296-001-133-006

NOTES:

1. FOR FULL ASSEMBLY PROCEDURE REFER TO APPLICATION NOTES 201-01-175.
2. THE SAME WIRE STRIP LENGTH APPLIES TO ALL STYLES.
3. STRANDED WIRES SHOULD BE TWISTED TO PREVENT SINGLE STRANDS BECOMING DETACHED WHEN INSERTED INTO CONTACT.

POKE-HOME: MICRO SINGLE VERTICAL CONTACT

22-26 AWG: 70-9296

General Information

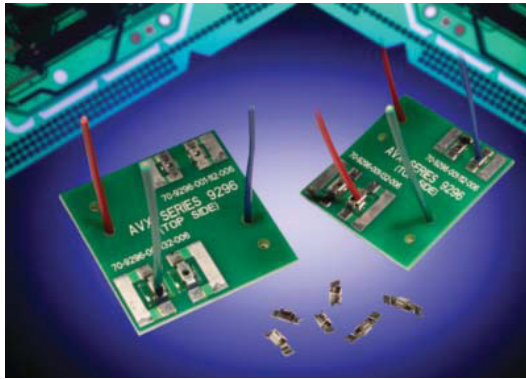

KYOCERA AVX continues to develop innovative connectors for the industrial electronics market that provide significant benefits over existing, outdated connector solutions. The latest release is single vertical Wire-to-Board (WTB) contacts that provide cost effective, yet robust discrete wire termination without the expense of an insulator and assembly costs. This new family of top and bottom entry contacts compliments the existing vertical poke home connectors already on the market, providing a lower cost solution without jeopardizing performance.

The new contacts support both solid and stranded wires ranging from 26AWG down to 22AWG and current ratings as high as 8 amps. Due to the mechanical stiffness of the small contact, 26AWG stranded wires may need to be pre-tinned to facilitate insertion. The set of four contacts provide both top and bottom entry for FR4 and metal core printed circuit boards.

APPLICATIONS

- Machine Controls: motors, drives, solenoids, sensors, fans and pumps
- Commercial Buildings: controls, security, fire and sensors
- Smart Grid: meters, breakers and panels
- SSL/LED; bulbs, fixtures, signage and streetlights
- Application notes: refer to 201-01-175

FEATURES AND BENEFITS

- Dual Beam contact provides maximum mechanical stability and wire retention
- Tape and reel packaged for automated SMT placement
- Staged current rating based on AWG, maximum is 8A (22AWG)
- Increased functionality with the single contact placement: multiple contacts and/or specific individual locations

ELECTRICAL

- Voltage Rating: 300V
Based on placement distance
- Current Rating: See matrix below

ENVIRONMENTAL

- Operating Temperature:
-40°C to +125°C

MECHANICAL

- Contact Material: Phosphor Bronze
- Contact Plating: Tin over Nickel
- Durability: 5 Cycles

HOW TO ORDER

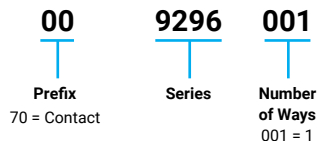

Code	Contact Location	Wire Insertion Direction	Recommended For Board Type	Wire Gauges*
102	Top Side	Bottom Entry	FR4	22 AWG - 26 AWG
112	Through Board	Top Entry	FR4	22 AWG - 26 AWG
122	Top Side	Bottom Entry	Metal Based	22 AWG - 26 AWG
132	Through Board	Top Entry	Metal Based	22 AWG - 26 AWG

* 26 AWG stranded wires may require tinning to aid insertion.



CURRENT RATING

22AWG	24AWG	26AWG
8A	6A	5A

Certification: UL File #E90723

POKE-HOME: MICRO SINGLE VERTICAL CONTACT

22-26 AWG: 70-9296

Top Side Contact - Bottom Entry Wire (FR4 Board)

70-9296-001-102-006

9296 VERTICAL MOUNT SMT CONTACT

TOP SIDE CONTACT – BOTTOM ENTRY WIRE (FR4 BOARD)

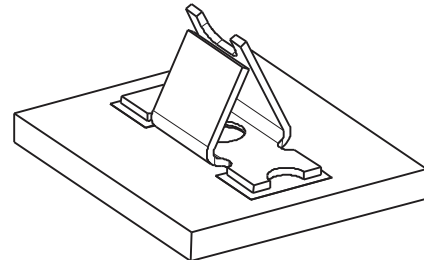
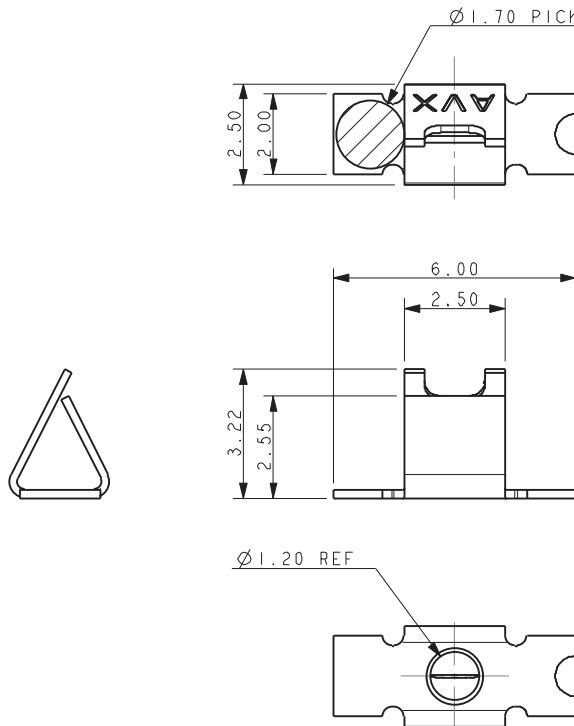

TOP SIDE CONTACT

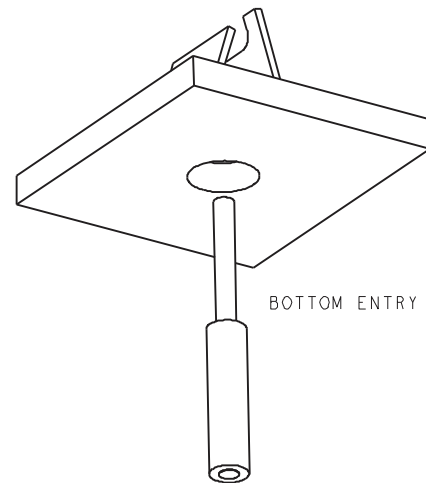

BOTTOM ENTRY WIRE

SUGGESTED PCB LAYOUT

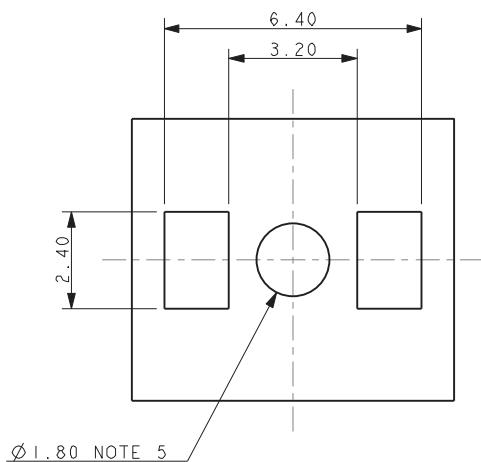

NOTES:

- CONTACT MOUNTS ON TOP SIDE OF BOARD, WIRE INSERTED FROM UNDERSIDE OF BOARD.
- STYLE RECOMMENDED FOR FR4 BOARDS WHERE ADDITIONAL CLEARANCE REQUIRED TO CONTACTS AND MOUNTING PADS.
- FOR FURTHER INFORMATION REFER TO ELCO SPECIFICATION 201-01-161 AND APPLICATION NOTES 201-01-175.
- MATERIAL: TIN PLATED PHOSPHOR BRONZE.
- HOLE FOR WIRE INSERTION.
- PACKING IN TAPE AND REEL, 2000 PIECES PER REEL.
- FOR WIRE TRIM DETAILS REFER TO PAGE 121.
- WIRE SIZES REFER TO PAGE 116.
- GENERAL TOLERANCE ± 0.10 .
- UL REFERENCE E90723 (US AND CANADA).

PACKING DETAILS

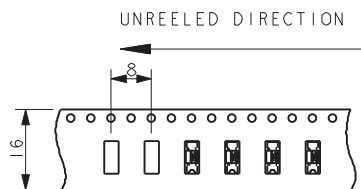

QUANTITY 2000 PER REEL

UNREELED DIRECTION

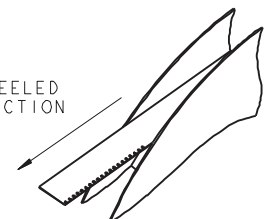

330mm DIAMETER REEL

POKE-HOME: MICRO SINGLE VERTICAL CONTACT

22-26 AWG: 70-9296

Through Board Contact - Top Entry Wire (FR4 Board)

70-9296-001-112-006

9296 VERTICAL MOUNT SMT CONTACT

THROUGH BOARD CONTACT – TOP ENTRY WIRE (FR4 BOARD)

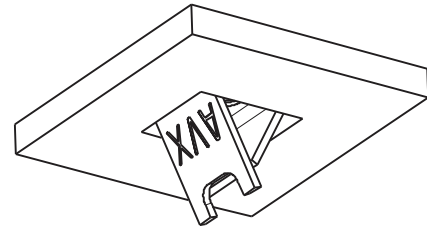
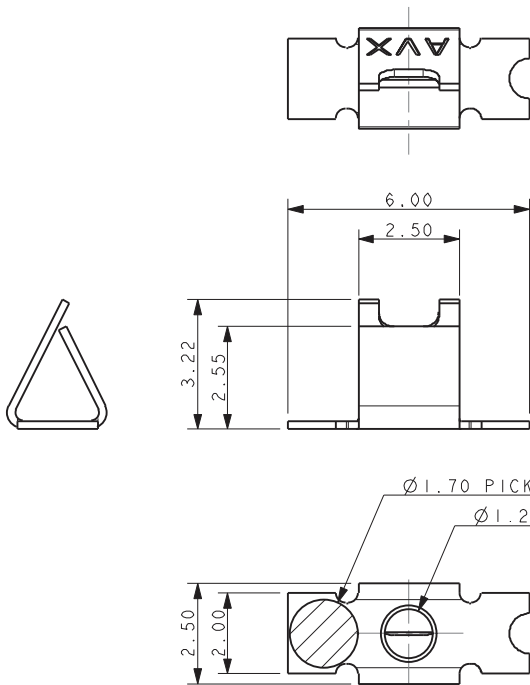

THROUGH BOARD CONTACT

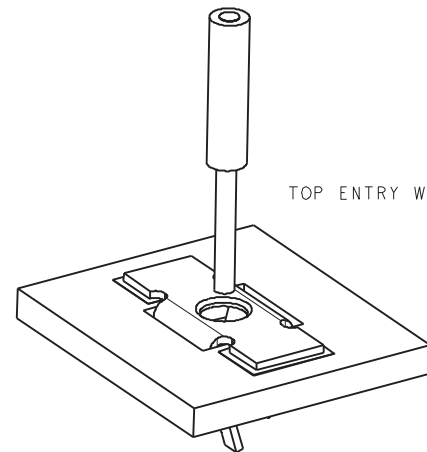

TOP ENTRY WIRE

SUGGESTED PCB LAYOUT

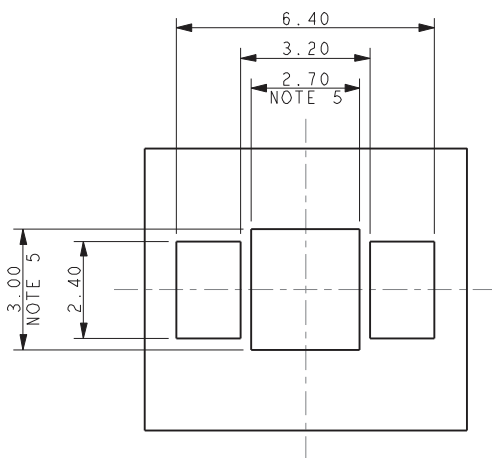

NOTES:

- CONTACT MOUNTS THROUGH THE BOARD, WIRE INSERTED FROM TOP SIDE OF BOARD.
- STYLE RECOMMENDED FOR FR4 BOARDS WHERE ADDITIONAL CLEARANCE REQUIRED TO CONTACT AND MOUNTING PADS.
- FOR FURTHER INFORMATION REFER TO ELCO SPECIFICATION 201-01-161 AND APPLICATION NOTES 201-01-175.
- MATERIAL: TIN PLATED PHOSPHOR BRONZE.
- HOLE DIMENSIONS FOR CONTACT.
- PACKING IN TAPE AND REEL, 2000 PIECES PER REEL.
- FOR WIRE TRIM DETAILS REFER TO PAGE 121.
- WIRE SIZES REFER TO PAGE 116.
- GENERAL TOLERANCE ± 0.10 .
- UL REFERENCE E90723 (US AND CANADA).

PACKING DETAILS

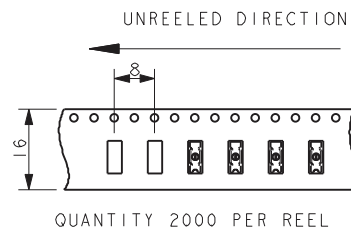

QUANTITY 2000 PER REEL

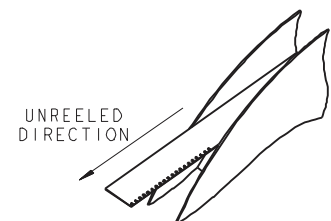

330mm DIAMETER REEL

POKE-HOME: MICRO SINGLE VERTICAL CONTACT

22-26 AWG: 70-9296

Top Side Contact - Bottom Entry Wire (Metal Board)

70-9296-001-122-006

9296 VERTICAL MOUNT SMT CONTACT

TOP SIDE CONTACT – BOTTOM ENTRY WIRE (METAL BOARD)

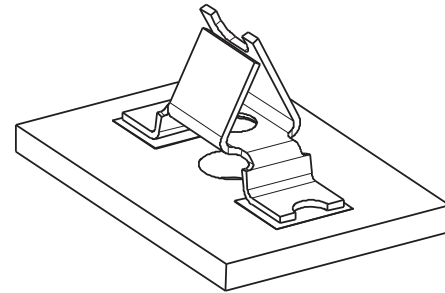
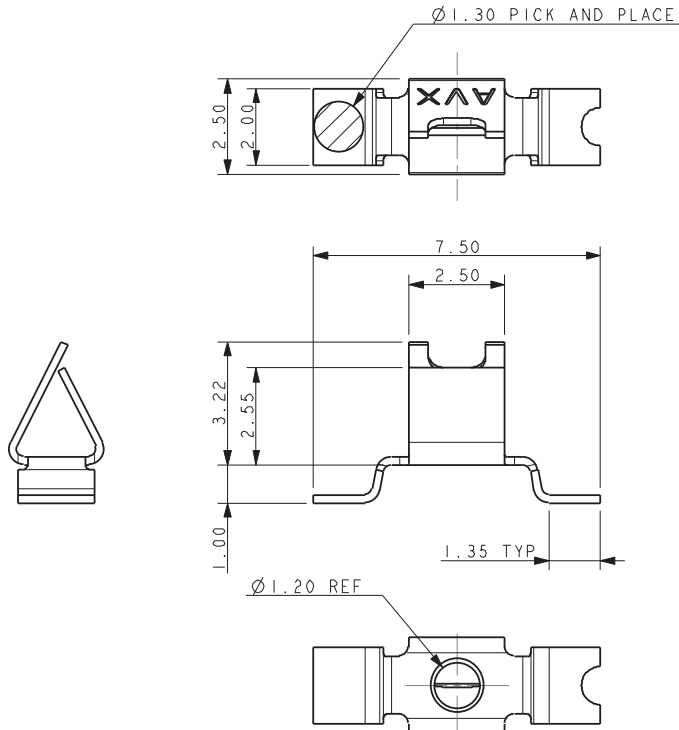

TOP SIDE CONTACT

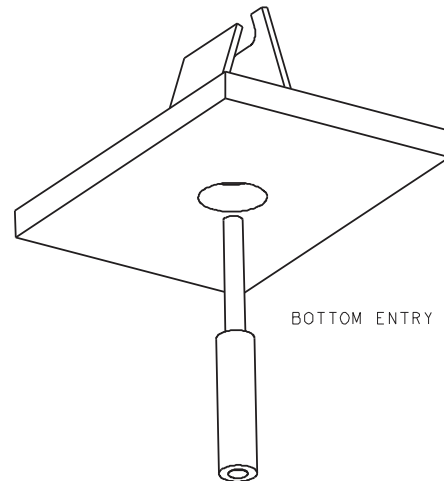

BOTTOM ENTRY WIRE

SUGGESTED PCB LAYOUT

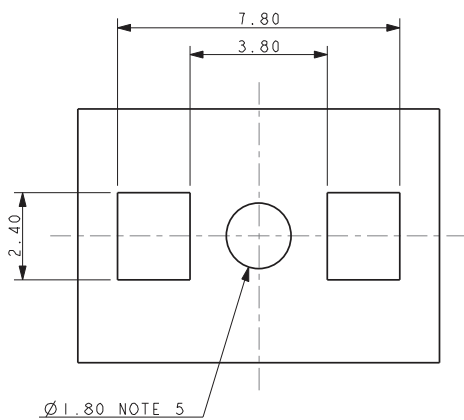

NOTES:

- CONTACT MOUNTS ON TOP SIDE OF BOARD, WIRE INSERTED FROM UNDERSIDE OF BOARD.
- STYLE RECOMMENDED FOR METAL CLAD BOARDS WHERE ADDITIONAL CLEARANCE REQUIRED TO CONTACTS AND MOUNTING PADS.
- FOR FURTHER INFORMATION REFER TO ELCO SPECIFICATION 201-01-161 AND APPLICATION NOTES 201-01-150.
- MATERIAL: TIN PLATED PHOSPHOR BRONZE.
- HOLE FOR WIRE INSERTION.
- PACKING IN TAPE AND REEL, 1600 PIECES PER REEL.
- FOR WIRE TRIM DETAILS REFER TO PAGE 121.
- WIRE SIZES REFER TO PAGE 116.
- GENERAL TOLERANCE ± 0.10 .
- UL REFERENCE E90723 (US AND CANADA).

PACKING DETAILS

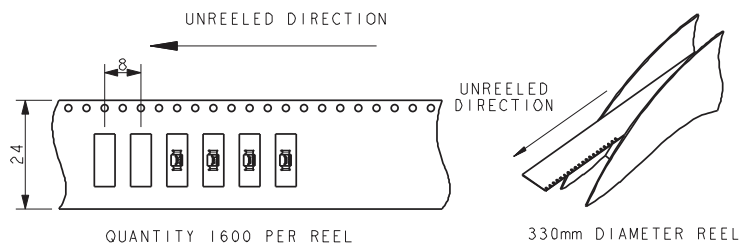

POKE-HOME: MICRO SINGLE VERTICAL CONTACT

22-26 AWG: 70-9296

Through Board Contact - Top Entry Wire (Metal Board)

70-9296-001-132-006

9296 VERTICAL MOUNT SMT CONTACT

THROUGH BOARD CONTACT – TOP ENTRY WIRE (METAL BOARD)

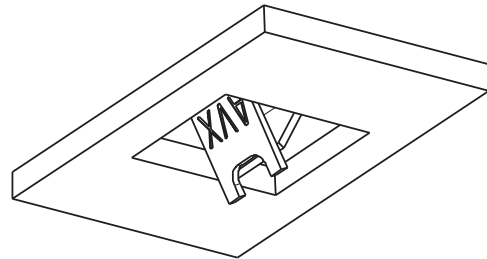
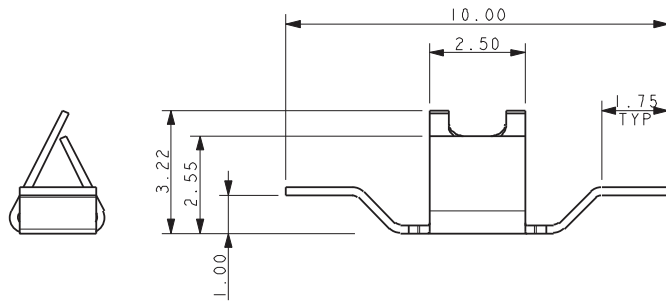

THROUGH BOARD CONTACT

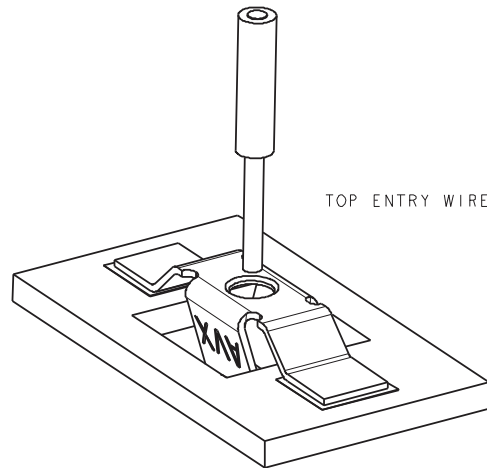
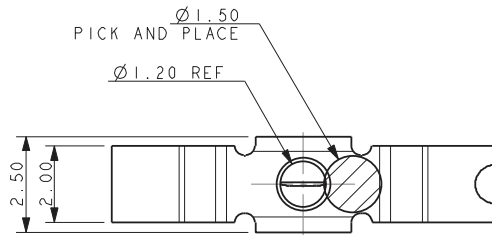

TOP ENTRY WIRE

SUGGESTED PCB LAYOUT

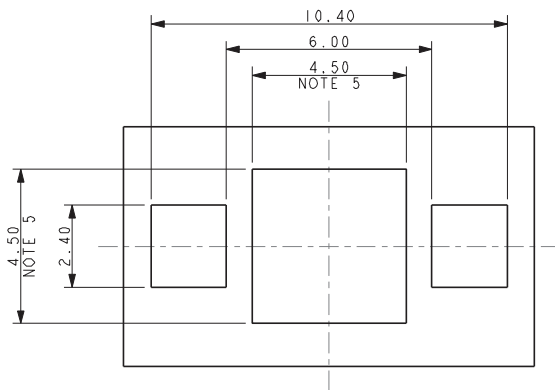

NOTES:

- CONTACT MOUNTS ON TOP SIDE OF BOARD, WIRE INSERTED FROM UNDERSIDE OF BOARD.
- STYLE RECOMMENDED FOR METAL CLAD BOARDS WHERE ADDITIONAL CLEARANCE REQUIRED TO CONTACTS AND MOUNTING PADS.
- FOR FURTHER INFORMATION REFER TO ELCO SPECIFICATION 201-01-161 AND APPLICATION NOTES 201-01-175.
- MATERIAL: TIN PLATED PHOSPHOR BRONZE.
- HOLE FOR WIRE INSERTION.
- PACKING IN TAPE AND REEL, 2000 PIECES PER REEL.
- FOR WIRE TRIM DETAILS REFER TO PAGE 121.
- WIRE SIZES REFER TO PAGE 116.
- GENERAL TOLERANCE ± 0.10 .
- UL REFERENCE E90723 (US AND CANADA).

PACKING DETAILS

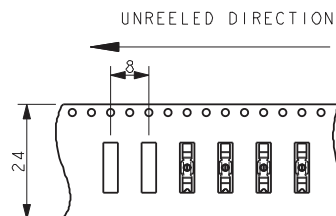

QUANTITY 2000 PER REEL

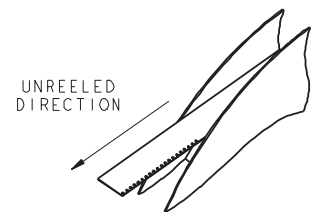

330mm DIAMETER REEL

POKE-HOME: MICRO SINGLE VERTICAL CONTACT

22-26 AWG: 70-9296

Wire Trim Details

9296 VERTICAL MOUNT SMT CONTACT WIRE TRIM DETAILS

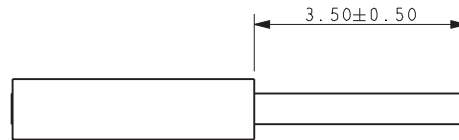

WIRE STRIP LENGTH, ALL STYLES

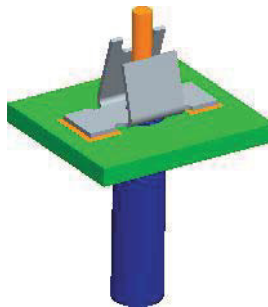

70-9296-001-103-006

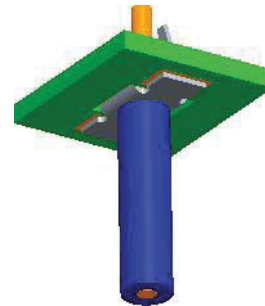

70-9296-001-113-006

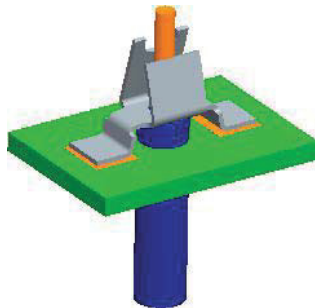

70-9296-001-123-006

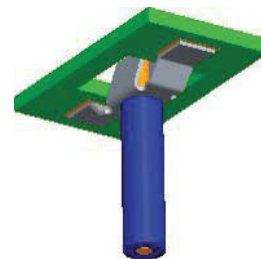

70-9296-001-133-006

NOTES:

1. FOR FULL ASSEMBLY PROCEDURE REFER TO APPLICATION NOTES 201-01-175.
2. THE SAME WIRE STRIP LENGTH APPLIES TO ALL STYLES.
3. STRANDED WIRES SHOULD BE TWISTED TO PREVENT SINGLE STRANDS BECOMING DETACHED WHEN INSERTED INTO CONTACT.
4. SUITABLE FOR SOLID AND STRANDED WIRES 22AWG, 24AWG AND 26AWG. STRANDED WIRES 26AWG MAY REQUIRE TINNING TO AID INSERTION.

POKE-HOME: LOW PROFILE HORIZONTAL

20-26 AWG: 9296-200

General Information

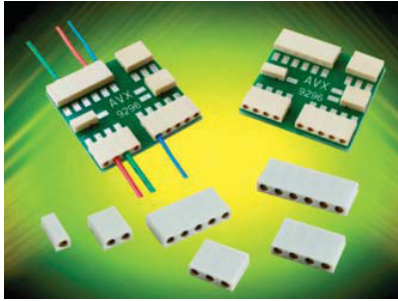

The new 9296 series connector provides a quick and reliable wire-to-board termination in a sleek 3.0mm pitch by 2.5mm high SMT package for a broad range of industrial and commercial applications. With almost every product on the market having to deal with a small number of discrete wires connecting components to a PCB, the 9296 connector series meets this challenge by simply stripping the wire and inserting them into a 1 to 6 position connector. This makes the connector very cost effective and termination friendly within the factory as well as in the field by electrical installers.

Developed for harsh industrial applications, the connector integrates the already proven 2mm dual beam poke-home contact into a connector housing. The high spring force Phosphor Bronze contact accepts a wide range (20-26AWG solid or stranded) of wire to accommodate any wire combination within a single connector.

APPLICATIONS

- Machine Controls: motors, drives, solenoids, sensors, fans and pumps
- Commercial Buildings: controls, security, fire and sensors
- Smart Grid: meters, breakers and panels
- SSL/LED: bulbs, fixtures, signage and streetlights
- Application notes: refer to 201-01-167

FEATURES AND BENEFITS

- Simple strip and poke-home wire insertion with easy twist and pull wire extraction
- 2.5mm height achieves the lowest height possible for this AWG range
- Accepts 20-26 AWG solid and stranded wires
- High spring force dual beam box contact provides maximum mechanical stability and wire retention
- UL approved
- Halogen free

ELECTRICAL

- Current Rating: See matrix below
- Voltage Rating: 300 VAC

ENVIRONMENTAL

- Operating Temperature: -40°C to +130°C

MECHANICAL

- Insulator Material: Glass-Filled Nylon 46; UL94V0
- Contact Material: Phosphor Bronze
- Plating: Tin over Nickel
- Durability: 3 Cycles

HOW TO ORDER

00	9296	00X	2X	2	X	X	6
Prefix	Series	Number of Ways	Description	Wire Gauge Size	Insulator Color	Halogen Free	Plating Options
		001 = 1 002 = 2 003 = 3 004 = 4 005 = 5 006 = 6	20 = Horizontal SMT Mount Poke Home Connector 21 = Horizontal SMT Mount Poke Home Connector for pass through mating pins	20AWG to 26AWG Max ø 1.60mm	All Sizes 9 = UL White (Standard) 8 = UL Black (Special Order)	0 = No 1 = Yes	6 = Pure Tin over Nickel
					One Way Only (Special Order) 2 = UL Brown 3 = UL Blue 4 = UL Yellow 5 = UL Red 6 = UL Green 7 = UL Orange		



CURRENT RATING

	20AWG	22AWG	24AWG	26AWG
UL	8A	7A	6A	5A
cUL	6A	5A	3.75A	3.75A

Certification: UL File #E90723

POKE-HOME: LOW PROFILE HORIZONTAL 20-26 AWG: 9296-200

1 Position

9296 HORIZONTAL MOUNT POKE HOME CONNECTOR – 1 WAY

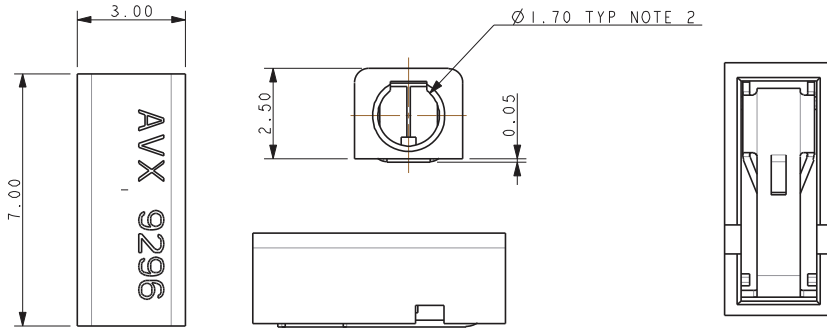

NOTES:

1. HORIZONTAL SMT MOUNT 1 WAY POKE HOME CONNECTOR. FOR FURTHER DETAILS REFER TO PRODUCT SPECIFICATION 201-01-166 AND APPLICATION NOTES 201-01-167.
2. SUITABLE FOR WIRES 20AWG TO 26AWG, MAXIMUM INSULATION 1.60MM DIAMETER.
3. INSULATOR: NYLON 46, GLASS FILLED, UL94 V-0, COLOR SEE PAGE 122.
4. CONTACT: TIN PLATED COPPER ALLOY.
5. PACKING IN TAPE AND REEL, QTY PER REEL 2000, 330MM REEL.
6. GENERAL TOLERANCE ± 0.20 .
7. OUTLINE OF CONNECTOR.
8. UL REFERENCE E90723 (US AND CANADA).

SUGGESTED PCB LAYOUT

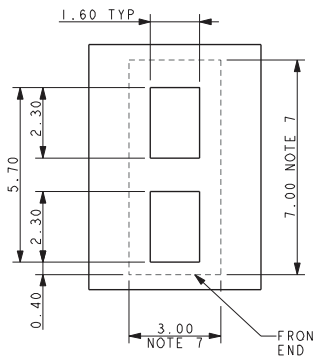

PACKING DETAILS

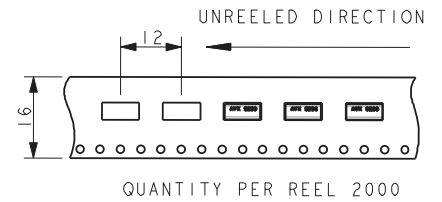
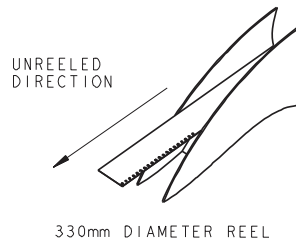

POKE-HOME: LOW PROFILE HORIZONTAL

20-26 AWG: 9296-200

2 Position

9296 HORIZONTAL MOUNT POKE HOME CONNECTOR – 2 WAY

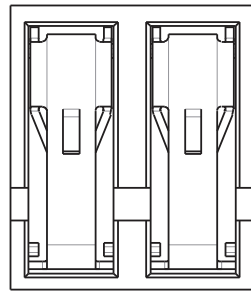
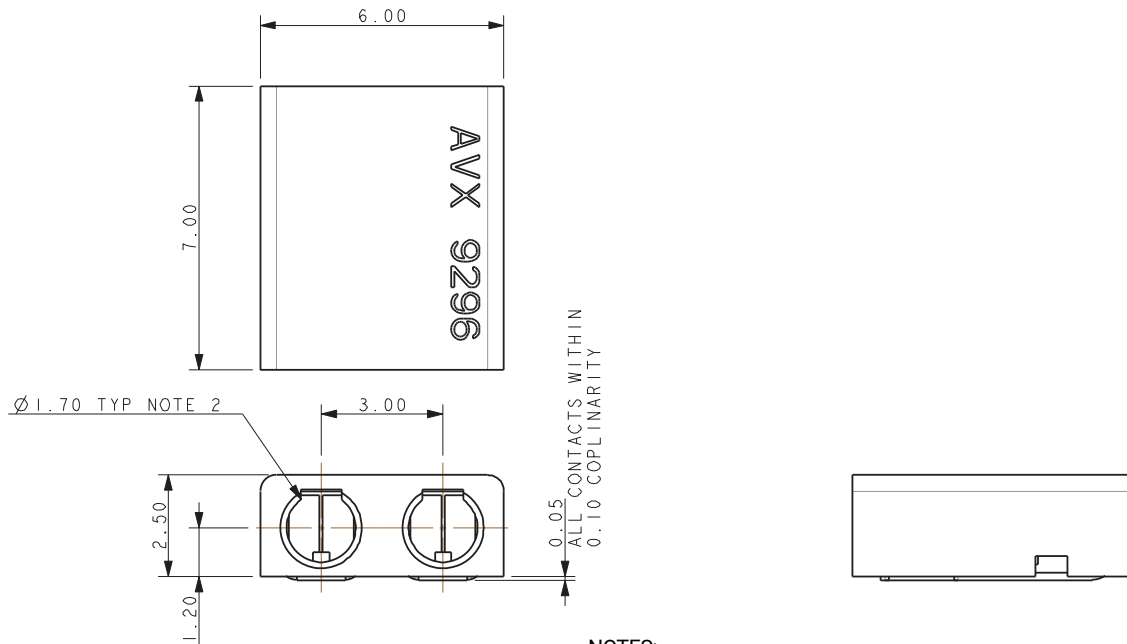

NOTES:

1. HORIZONTAL SMT MOUNT 2 WAY POKE HOME CONNECTOR. FOR FURTHER DETAILS REFER TO PRODUCT SPECIFICATION 201-01-166 AND APPLICATION NOTES 201-01-167.
2. SUITABLE FOR WIRES 20AWG TO 26AWG, MAXIMUM INSULATION 1.60MM DIAMETER.
3. INSULATOR: NYLON 46, GLASS FILLED, UL94 V-0, COLOR SEE PAGE 122.
4. CONTACT: TIN PLATED COPPER ALLOY.
5. PACKING IN TAPE AND REEL, QTY PER REEL 2000, 330MM REEL.
6. GENERAL TOLERANCE ± 0.20 .
7. OUTLINE OF CONNECTOR.
8. UL REFERENCE E90723 (US AND CANADA).

SUGGESTED PCB LAYOUT

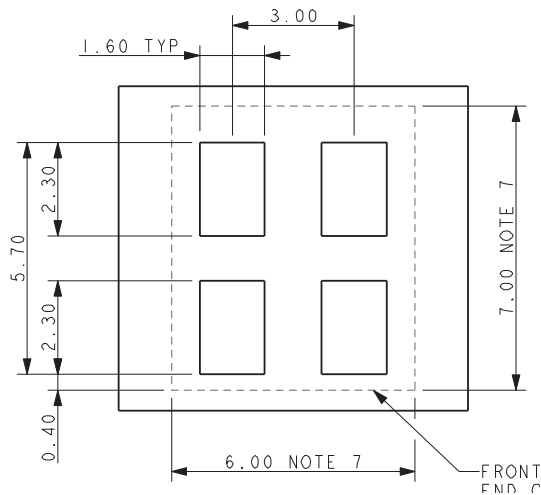

PACKING DETAILS

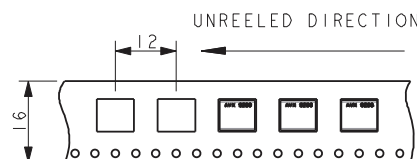
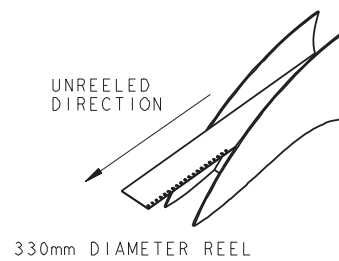

QUANTITY PER REEL 2000

POKE-HOME: LOW PROFILE HORIZONTAL

20-26 AWG: 9296-200

3 Position

9296 HORIZONTAL MOUNT POKE HOME CONNECTOR – 3 WAY

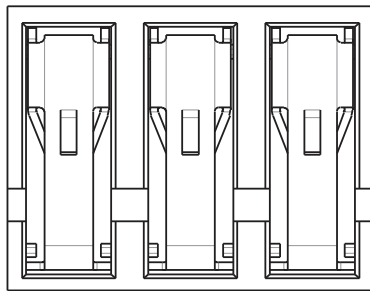
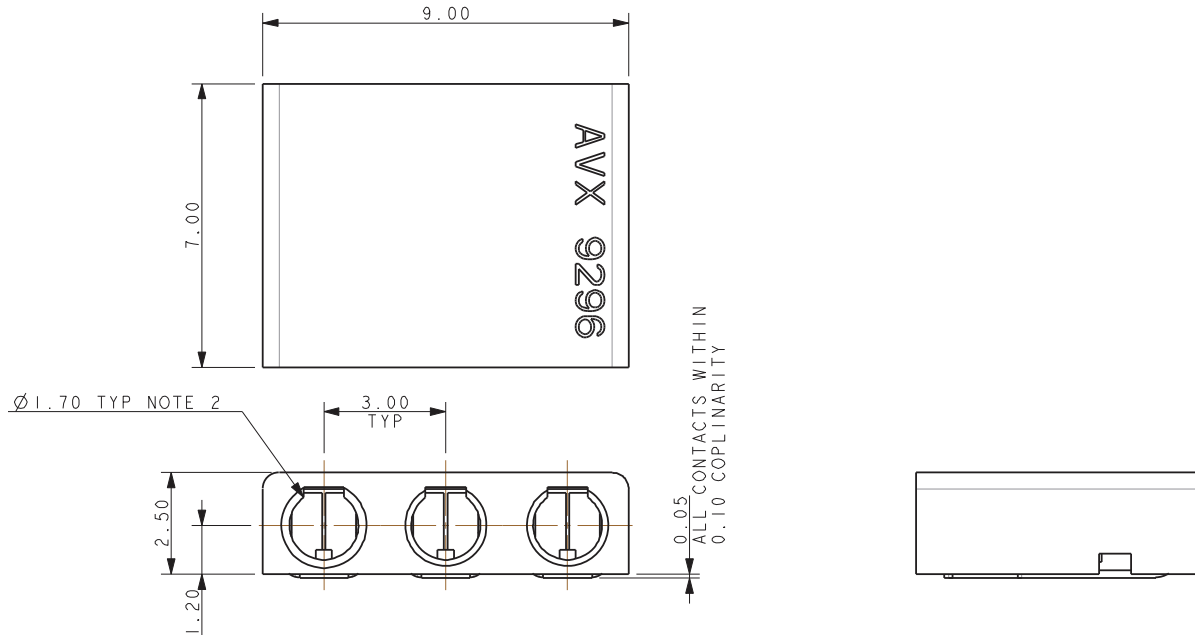

NOTES:

1. HORIZONTAL SMT MOUNT 3 WAY POKE HOME CONNECTOR. FOR FURTHER DETAILS REFER TO PRODUCT SPECIFICATION 201-01-166 AND APPLICATION NOTES 201-01-167.
2. SUITABLE FOR WIRES 20AWG TO 26AWG, MAXIMUM INSULATION 1.60MM DIAMETER.
3. INSULATOR: NYLON 46, GLASS FILLED, UL94 V-0, COLOR SEE PAGE 122.
4. CONTACT: TIN PLATED COPPER ALLOY.
5. PACKING IN TAPE AND REEL, QTY PER REEL 2000, 330MM REEL.
6. GENERAL TOLERANCE ± 0.20 .
7. OUTLINE OF CONNECTOR.
8. UL REFERENCE E90723 (US AND CANADA).

SUGGESTED PCB LAYOUT

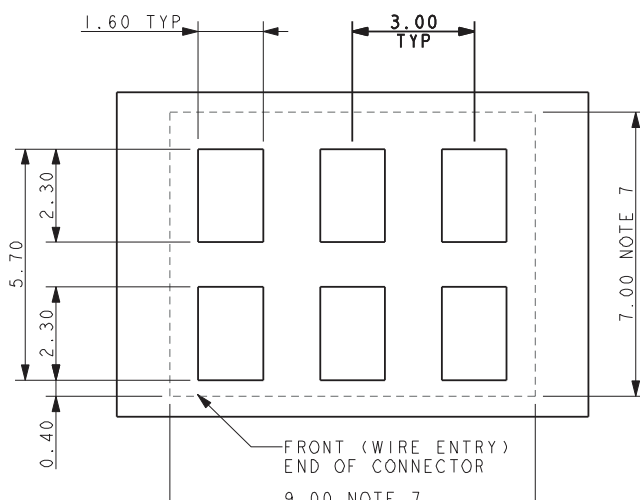

PACKING DETAILS

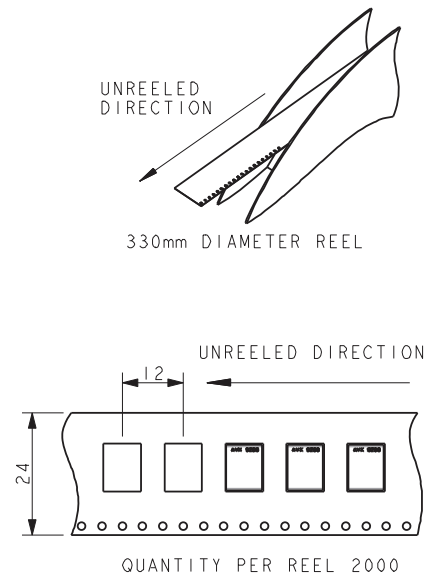

POKE-HOME: LOW PROFILE HORIZONTAL

20-26 AWG:9296-200

4 Position

9296 HORIZONTAL MOUNT POKE HOME CONNECTOR – 4 WAY

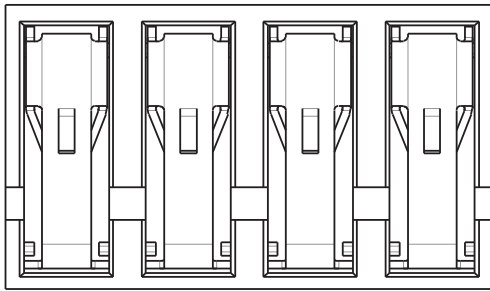
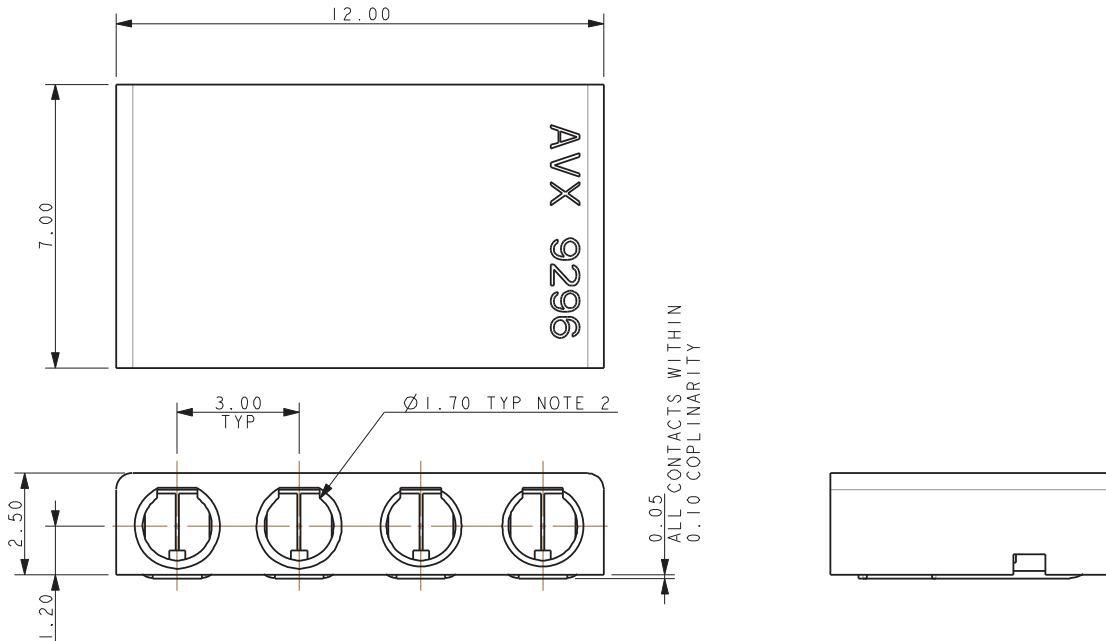

NOTES:

1. HORIZONTAL SMT MOUNT 4 WAY POKE HOME CONNECTOR. FOR FURTHER DETAILS REFER TO PRODUCT SPECIFICATION 201-01-166 AND APPLICATION NOTES 201-01-167.
2. SUITABLE FOR WIRES 20AWG TO 26AWG, MAXIMUM INSULATION 1.60MM DIAMETER.
3. INSULATOR: NYLON 46, GLASS FILLED, UL94 V-0, COLOR SEE PAGE 122.
4. CONTACT: TIN PLATED COPPER ALLOY.
5. PACKING IN TAPE AND REEL, QTY PER REEL 2000, 330MM REEL.
6. GENERAL TOLERANCE ± 0.20 .
7. OUTLINE OF CONNECTOR.
8. UL REFERENCE E90723 (US AND CANADA).

SUGGESTED PCB LAYOUT

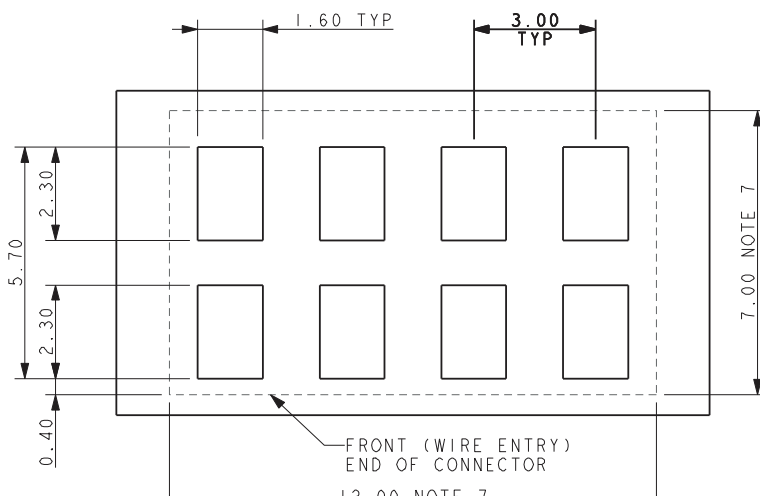

PACKING DETAILS

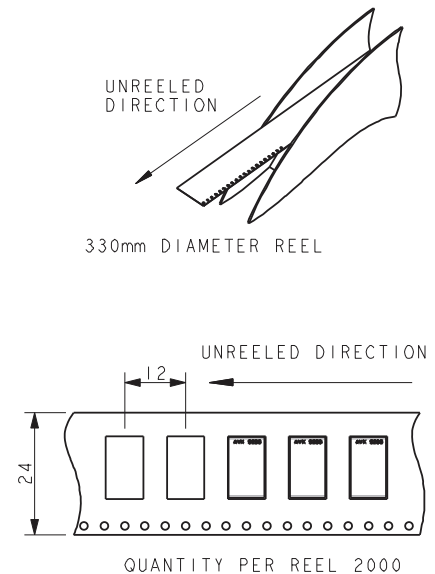

POKE-HOME: LOW PROFILE HORIZONTAL

20-26 AWG: 9296-200

5 Position

9296 HORIZONTAL MOUNT POKE HOME CONNECTOR – 5 WAY

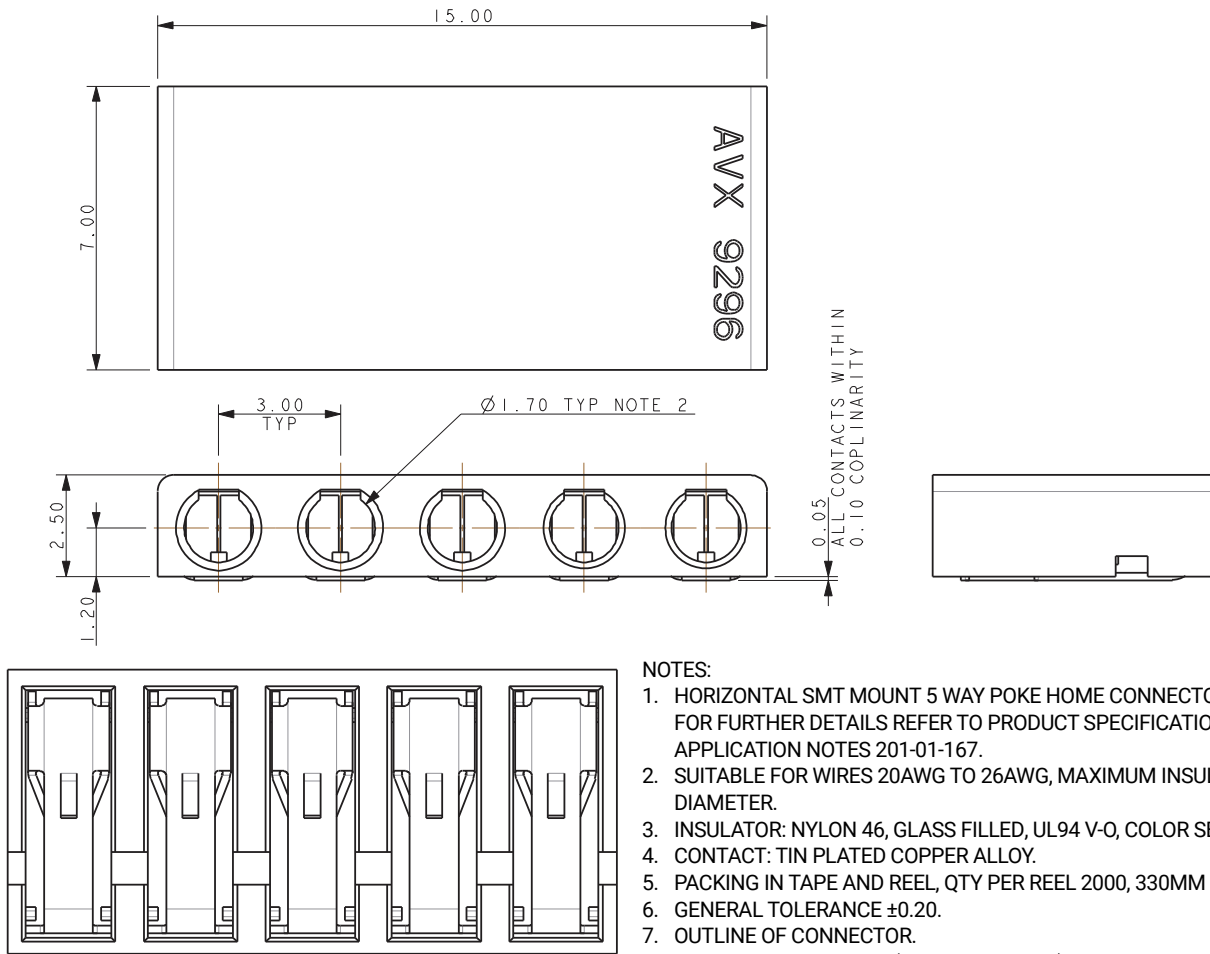

SUGGESTED PCB LAYOUT

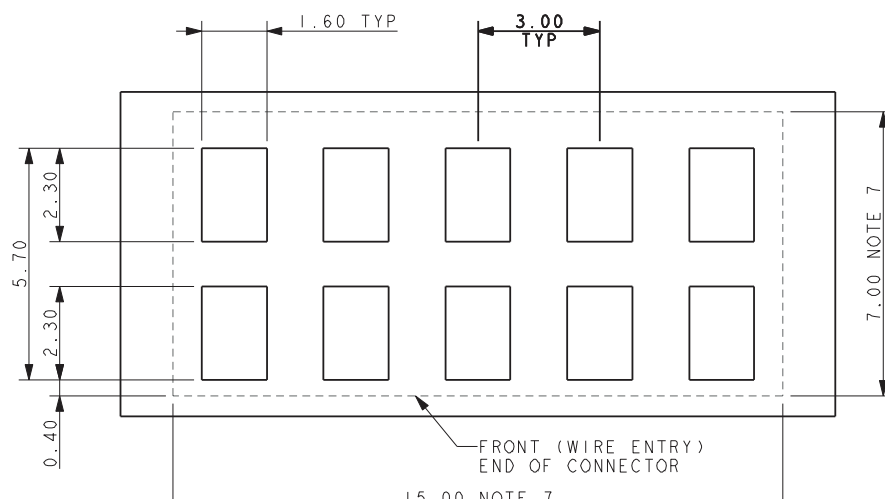

PACKING DETAILS

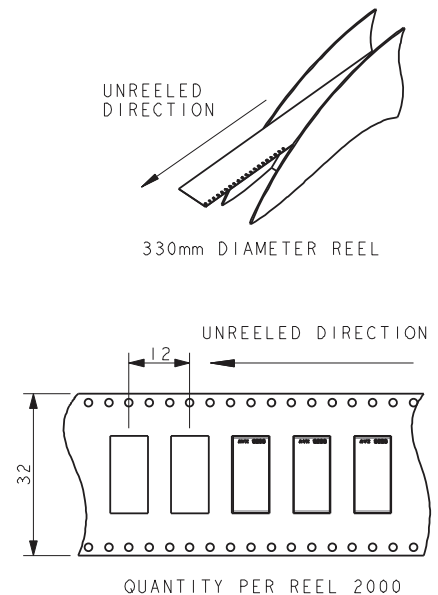

POKE-HOME: LOW PROFILE HORIZONTAL

20-26 AWG: 9296-200

6 Position

9296 HORIZONTAL MOUNT POKE HOME CONNECTOR – 6 WAY

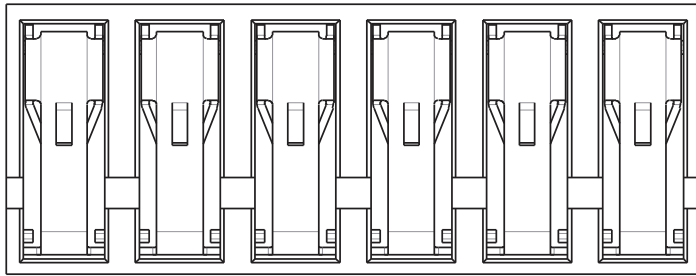
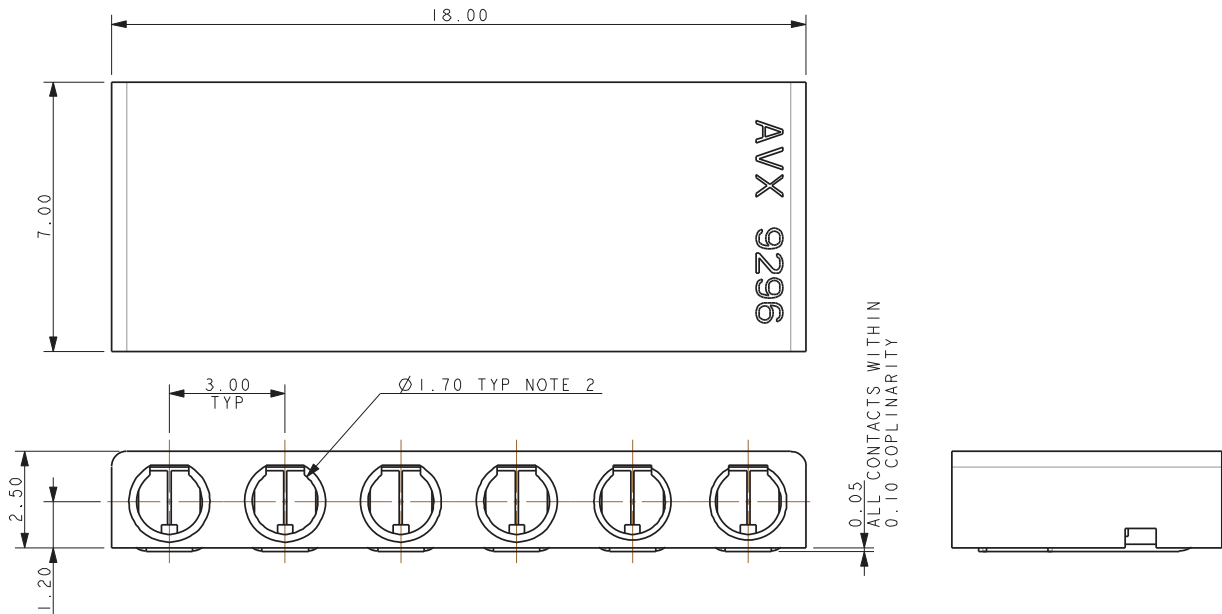

NOTES:

1. HORIZONTAL SMT MOUNT 6 WAY POKE HOME CONNECTOR. FOR FURTHER DETAILS REFER TO PRODUCT SPECIFICATION 201-01-166 AND APPLICATION NOTES 201-01-167.
2. SUITABLE FOR WIRES 20AWG TO 26AWG, MAXIMUM INSULATION 1.60MM DIAMETER.
3. INSULATOR: NYLON 46, GLASS FILLED, UL94 V-0, COLOR SEE PAGE 122.
4. CONTACT: TIN PLATED COPPER ALLOY.
5. PACKING IN TAPE AND REEL, QTY PER REEL 2000, 330MM REEL.
6. GENERAL TOLERANCE ± 0.20 .
7. OUTLINE OF CONNECTOR.
8. UL REFERENCE E90723 (US AND CANADA).

SUGGESTED PCB LAYOUT

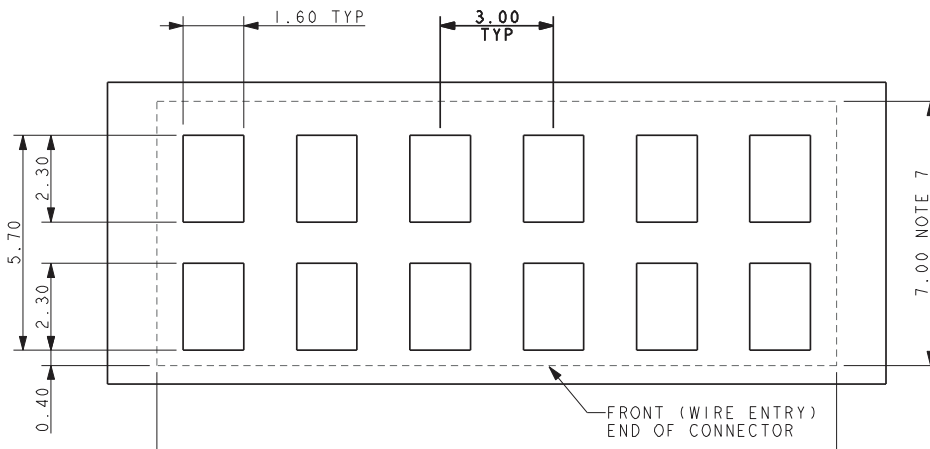

PACKING DETAILS

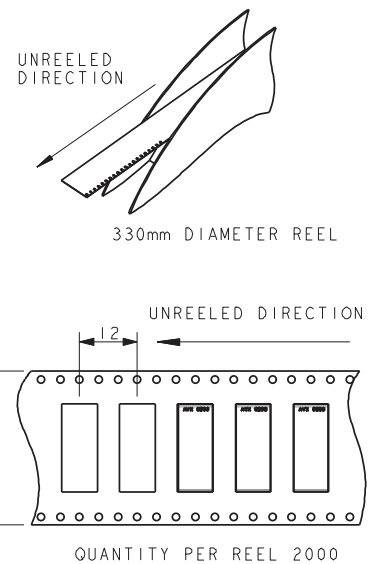

POKE-HOME: LOW PROFILE HORIZONTAL

20-26 AWG: 9296-200

Assembly

9296 HORIZONTAL MOUNT POKE HOME CONNECTOR – ASSEMBLY

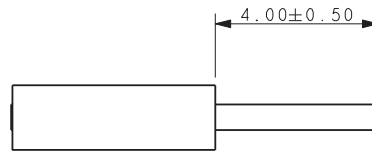

WIRE STRIP LENGTH

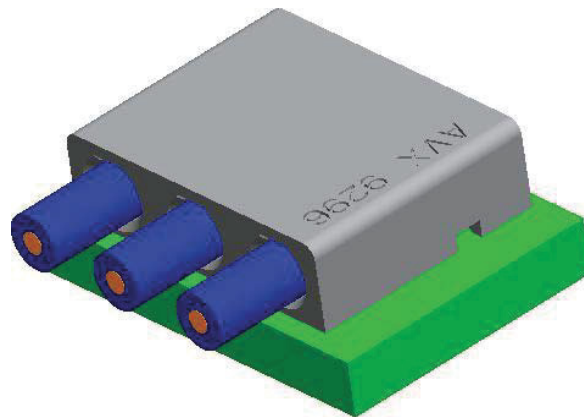

REFER TO APPLICATION NOTES 201-01-167
FOR FULL ASSEMBLY PROCEDURE

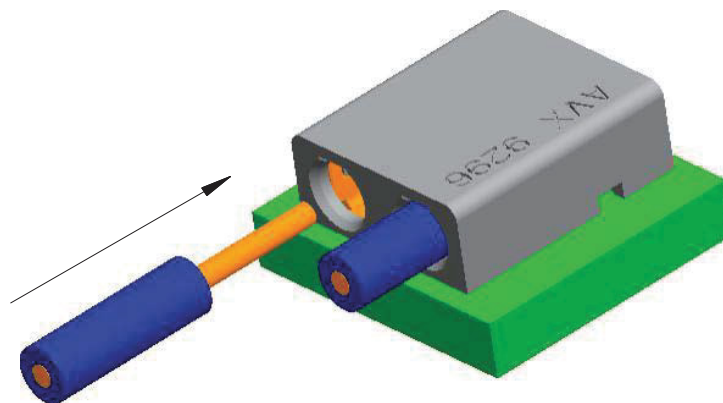

RF COAXIAL IDC

00-6791



GENERAL DESCRIPTION

Designed to simplify the connection process, the new 6791 series wire to board connectors for coaxial cables enable simple termination with one press. Expanded the proven-reliable IDC (Insulation displacement connector) from signal/power transmission to high frequency transmission field up to 6GHz, the IDC contact pierces the jacket and insulation of the cable and makes direct contact with the strands and conductor of the wire at the same time. Comparing with direct soldering the soldering quality is no more depending on operator's skill which is hard to be unified and controlled. Hand soldering is now not preferred/allowed in automotive field. Comparing with costly traditional 2-piece solution which is generally taller than 10mm, the new 6791 Series offers a cost-effective solution and the on board height in less than 5mm after the cap is pressed. Process to prepare coaxial cable with a 2-piece connector is time consuming and costly, with the launch of the new 6791 series the process is now simplified and the cost is reduced.

APPLICATIONS

- The connector comes in multiple types for different coaxial cables.
- Small package size and mechanical strength allows usage in automotive and industrial antenna applications
- Reference Application Notes 201-01-214

ELECTRICAL

- Current Rating: 0.5 Amps (Current limit is cable dependent)
- Voltage Rating: 125Vac

ENVIRONMENTAL

- Operating Temperature: -40°C to +105°C

FEATURES AND BENEFITS

- Can replace costly traditional RF connector systems
- Good RF performance up to 6GHz
- Mechanically strong with peel off force up to 70N
- Easy assembly process with ability to automate

MECHANICAL

- Insulator Material: Glass-Filled Nylon 46; UL94V-0
- Contact Material: Copper Alloy
- Plating: Lead-Free Tin Over Nickel

HOW TO ORDER

00	6791	001	00X	005
Prefix	Series	No. of Ways 001 = 1	Description 001 = 50Q: Outer Jacket 2.33mm-2.60mm 003 = 50Q: Outer Jacket 2.70mm-3.10mm See comparison of cable dimensions in below chart	Plating



IDC COAX CABLE SIZE

Component	Diameter (mm)			
	-001		-003	
	Lower Limit	Upper Limit	Lower Limit	Upper Limit
Conductor	0.43	0.54	0.46	0.57
Dielectric	1.44	1.68	1.45	1.70
Braid Shield	1.84	2.08	1.85	2.10
Jacket	2.33	2.60	2.70	3.10

RF COAXIAL IDC

00-6791

00 6791 001 001 005

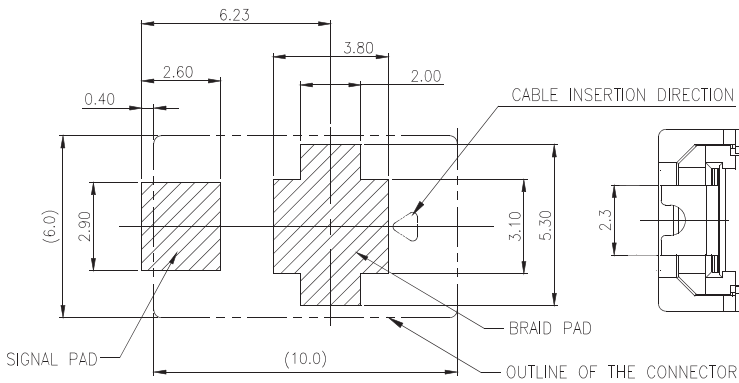
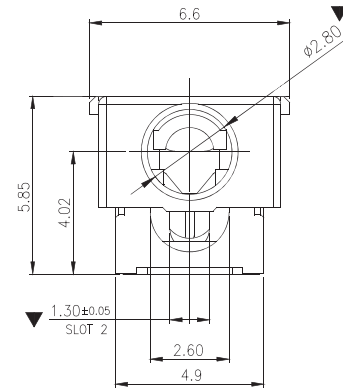
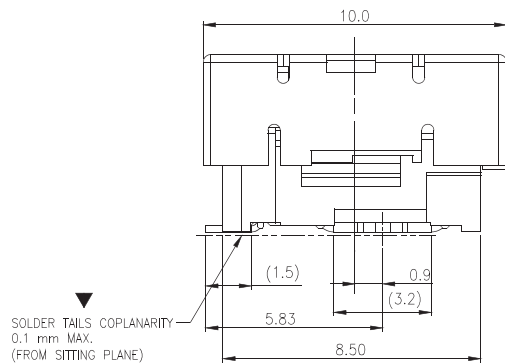
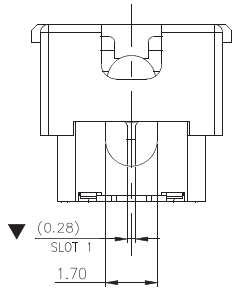
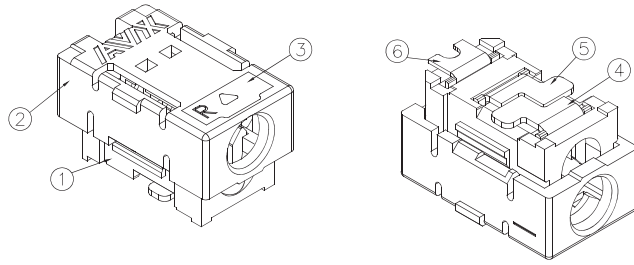
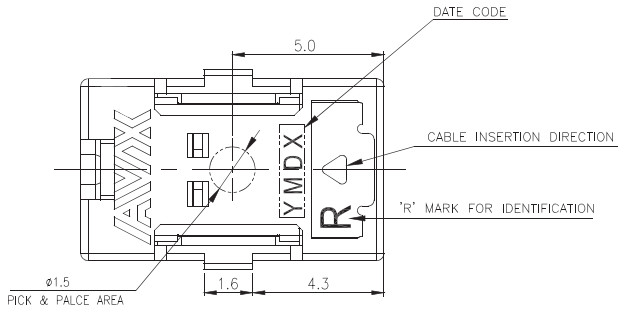

RECOMMENDED PCB LAYOUT
NOTE: TOLERANCE FOR PCB LAYOUT IS ± 0.05 mm

- NOTES:
- VOLTAGE RATING: 125V.
 - OPERATING TEMPERATURE: -40°C TO $+105^{\circ}\text{C}$.
 - FOR REFLOW SOLDERING LEAD-FREE PROCESS.
 - SOLDERING HEAT RESISTANCE REFLOW SOLDERING 260°C .
 - RECOMMENDED PRESSING STOP HEIGHT AS 3.9 ± 0.2 mm.
 - ALLOW CABLE INSERT TOLERANCE: 0.3mm MAX.
 - CRITICAL DIMENSION: \blacktriangledown
 - GENERAL TOLERANCE ± 0.20 mm.

ITEM	DESCRIPTION	MATERIAL	FINISH	Q'TY	NOTE
⑥	SIGNAL CONTACT	COPPER ALLOY	Tin OVERALL, NICKEL UNDERPLATED	1	
⑤	BRAID CONTACT(2)	COPPER ALLOY	Tin OVERALL, NICKEL UNDERPLATED	1	
④	BRAID CONTACT(1)	COPPER ALLOY	Tin OVERALL, NICKEL UNDERPLATED	1	
③	SUPPORT PLATE	STAINLESS STEEL		1	
②	CAP	PA-46	UL94HB, BLACK	1	
①	HOUSING	PA-46	UL94HB, BLACK	1	

RF COAXIAL IDC

00-6791

00 6791 001 001 005

CONSTRUCTION

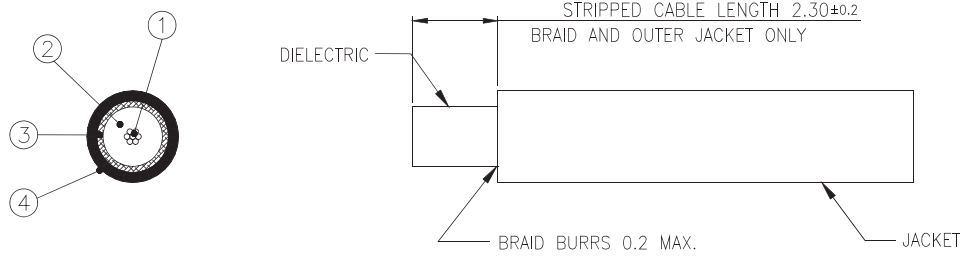

NOTE: JACKET STRIP OD DEFORMED MUST BE THAN LESS $\phi 2.75\text{mm}$ AFTER CUT OFF.

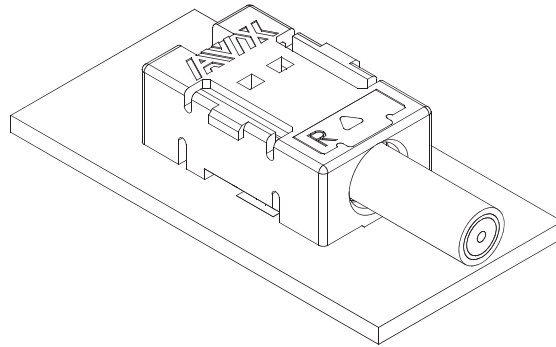

APPLICABLE COAXIAL CABLE DIMENSIONS:

COMPONENT	DIAMETER (mm)	
	LOWER LIMIT	UPPER LIMIT
(1) CONDUCTOR	$\phi 0.43$	$\phi 0.54$
(2) DIELECTRIC	$\phi 1.44$	$\phi 1.68$
(3) BRAID SHIELD	$\phi 1.84$	$\phi 2.08$
(4) JACKET	$\phi 2.33$	$\phi 2.60$

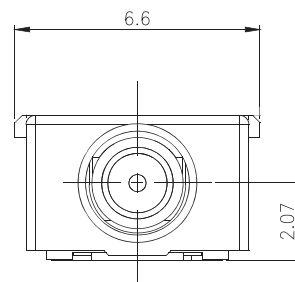
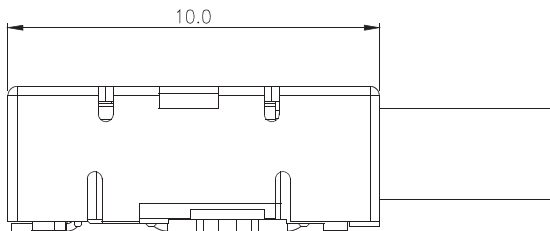

WIRED CONNECTOR

RF COAXIAL IDC

00-6791

00 6791 001 001 005

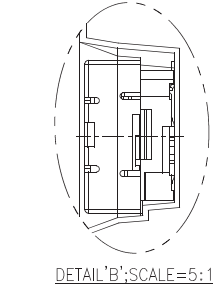
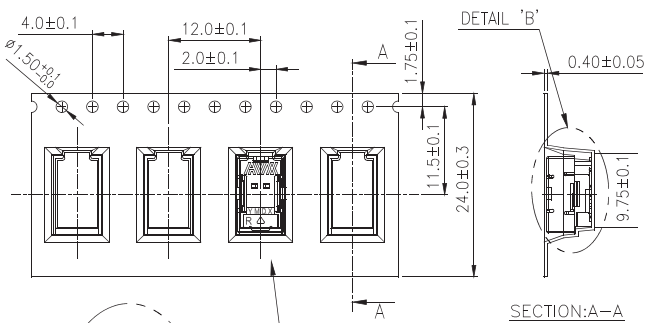
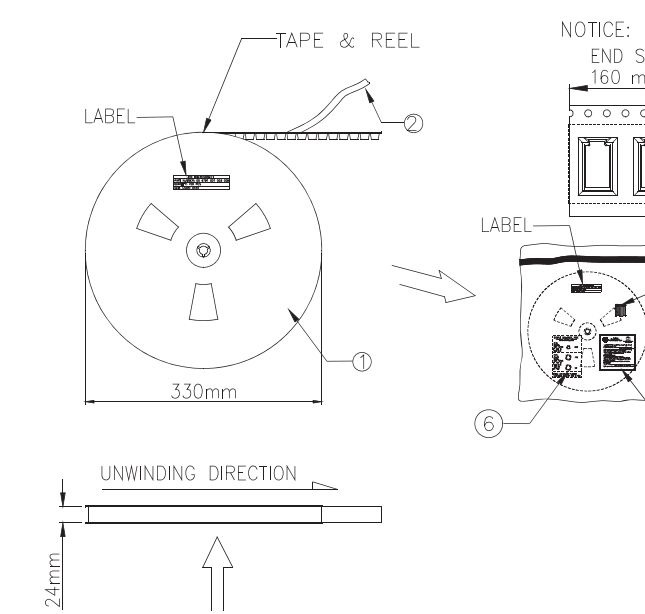

REEL LABEL

AVX INTERCONNECT
PART NUMBER: 00 6791 001 001 005
QUANTITY: 850 PCS
DATE CODE: XXXX

DETAIL 'B':SCALE=5:1

- NOTE :
- MATERIAL :
 REEL: BLUE PS
 CARRIER: BLACK PS
 COVER TAPE: TRANSPARENT PE
 - DIMENSION :
 REEL SIZE:
 DIA=330mm, W=24mm
 - QUANTITY:
 850PCS/REEL
 - HUMIDITY REQUIREMENTS FOLLOW
 MSL LEVEL 3

A	165~180°
F	35-125g

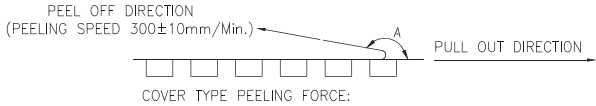

ITEM	DESCRIPTIONs	MATERIAL	FINISH	Q'TY	NOTE	COLOR
⑦	CAUTION LABEL	---	---	1	---	---
⑥	HUMIDITY INDICATOR CARD	---	---	1	---	---
⑤	DESICCANT	---	20g/Bag	1	---	---
④	ESD BAG	FOIL	VACUUM SEAL	1	---	---
③	ESD CARRIER TAPE	PS	---	1	---	---
②	ESD COVER TAPE	PE	---	1	---	---
①	REEL ASS'Y	PS	---	1	---	BLUE

RF COAXIAL IDC

00-6791

00 6791 001 001 005

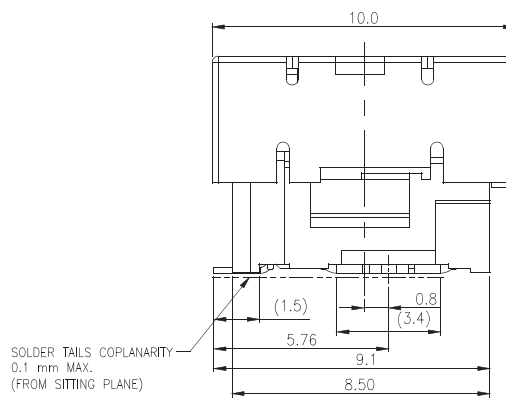
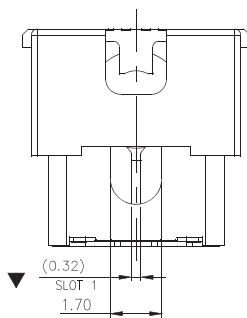
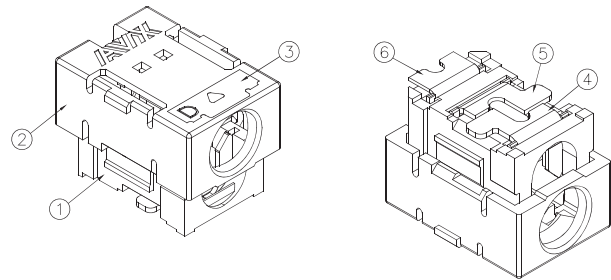
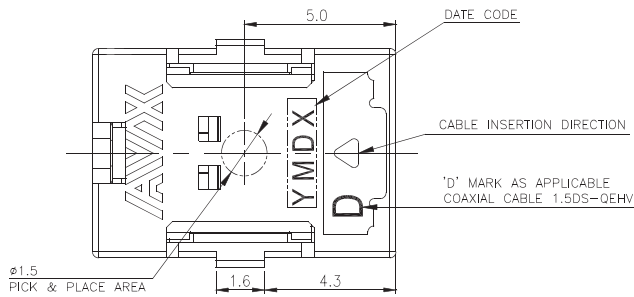

SOLDER TAILS COPLANARITY
0.1 mm MAX.
(FROM SITTING PLANE)

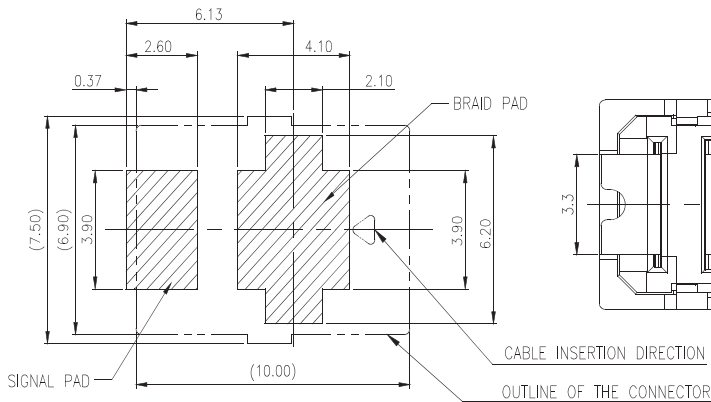
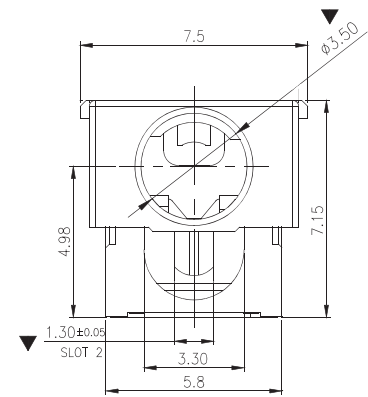

RECOMMENDED PCB LAYOUT
NOTE: TOLERANCE FOR PCB LAYOUT IS ± 0.05 mm

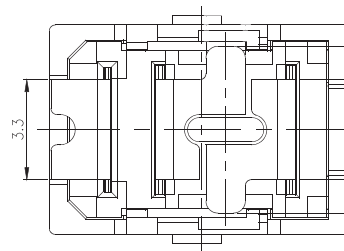

NOTES:

1. VOLTAGE RATING: 125v
2. OPERATING TEMPERATURE: -40°C TO +105°C.
3. FOR REFLOW SOLDERING LEAD-FREE PROCESS.
4. SOLDERING HEAT RESISTANCE REFLOW SOLDERING 260°C. ;
5. RECOMMENDED PRESSING STOP HEIGHT AS 4.5 ± 0.05 mm. ;
6. ALLOW CABLE INSERT TOLERANCE: 0.3mm MAX.
7. CRITICAL DIMENSION: ▼
8. GENERAL TOLERANCE ± 0.20 mm.

ITEM	DESCRIPTION	MATERIAL	FINISH	Q'TY	NOTE
⑥	SIGNAL CONTACT	COPPER ALLOY	Tin OVERALL, NICKEL UNDERPLATED	1	
⑤	BRAID CONTACT(2)	COPPER ALLOY	Tin OVERALL, NICKEL UNDERPLATED	1	
④	BRAID CONTACT(1)	COPPER ALLOY	Tin OVERALL, NICKEL UNDERPLATED	1	
③	SUPPORT PLATE	STAINLESS STEEL		1	
②	CAP	PA-46	UL94HB,BLACK	1	
①	HOUSING	PA-46	UL94HB,BLACK	1	

RF COAXIAL IDC

00-6791

00 6791 001 001 005

CONSTRUCTION

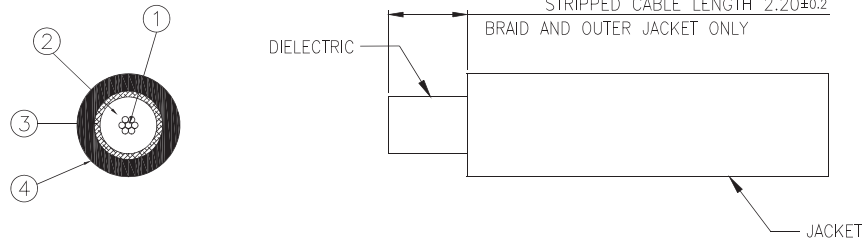

NOTE: JACKET STRIP OD DEFORMED MUST BE THAN LESS $\varnothing 3.30\text{mm}$ AFTER CUT OFF.

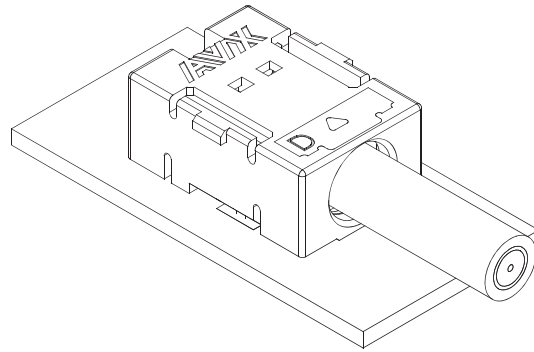

APPLICABLE COAXIAL CABLE DIMENSIONS:

COMPONENT	DIAMETER (mm)	
	LOWER LIMIT	UPPER LIMIT
(1) CONDUCTOR	$\varnothing 0.46$	$\varnothing 0.57$
(2) DIELECTRIC	$\varnothing 1.45$	$\varnothing 1.70$
(3) BRAID SHIELD	$\varnothing 1.85$	$\varnothing 2.10$
(4) JACKET	$\varnothing 2.70$	$\varnothing 3.10$



WIRED CONNECTOR

RF COAXIAL IDC

00-6791

00 6791 001 001 005

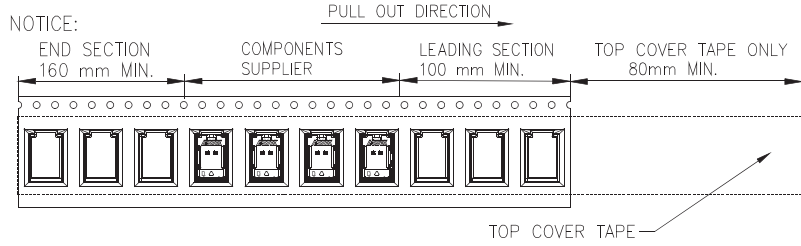
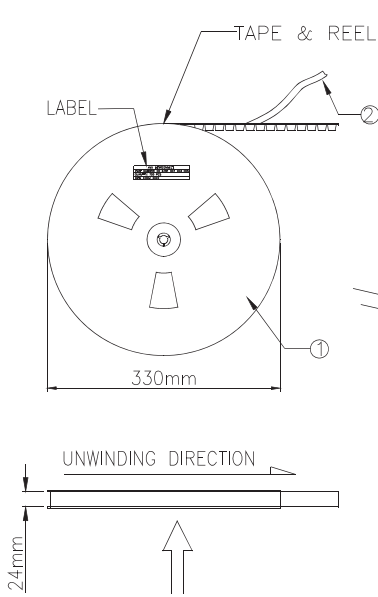

- NOTE :
- MATERIAL :
 REEL: BLUE PS
 CARRIER: BLACK PS
 COVER TAPE: TRANSPARENT PE
 - DIMENSION :
 REEL SIZE:
 DIA=330mm, W=24mm
 - QUANTITY:
 700PCS/REEL
 - HUMIDITY REQUIREMENTS FOLLOW
 MSL LEVEL 3

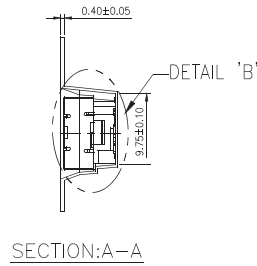
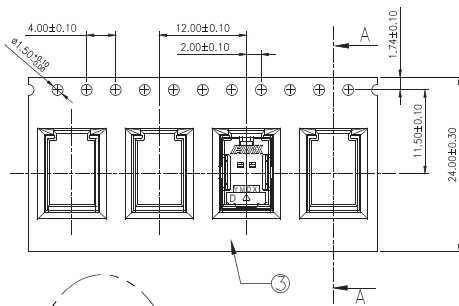

A	165°~180°
F	35~125g

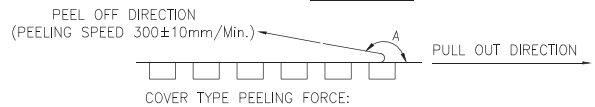

REEL LABEL

AVX INTERCONNECT	
PART NUMBER:	00 6791 001 003 005
QUANTITY:	700 PCS
DATE CODE:	XXXX

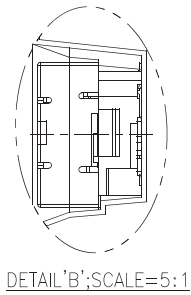

ITEM	DESCRIPTIONs	MATERIAL	FINISH	Q'TY	NOTE	COLOR
⑦	CAUTION LABEL	---	---	1	---	---
⑥	HUMIDITY INDICATOR CARD	---	---	1	---	---
⑤	DESICCANT	---	20g/Bag	1	---	---
④	ESD BAG	FOIL	VACUUM SEAL	1	---	---
③	ESD CARRIER TAPE	PS	---	1	---	---
②	ESD COVER TAPE	PE	---	1	---	---
①	REEL ASS'Y	PS	---	1	---	BLUE

Архангельск (8182)63-90-72
 Астана (7172)727-132
 Астрахань (8512)99-46-04
 Барнаул (3852)73-04-60
 Белгород (4722)40-23-64
 Брянск (4832)59-03-52
 Владивосток (423)249-28-31
 Волгоград (844)278-03-48
 Вологда (8172)26-41-59
 Воронеж (473)204-51-73
 Екатеринбург (343)384-55-89
 Иваново (4932)77-34-06

Ижевск (3412)26-03-58
 Иркутск (395)279-98-46
 Казань (843)206-01-48
 Калининград (4012)72-03-81
 Калуга (4842)92-23-67
 Кемерово (3842)65-04-62
 Киров (8332)68-02-04
 Краснодар (861)203-40-90
 Красноярск (391)204-63-61
 Курск (4712)77-13-04
 Липецк (4742)52-20-81
 Киргизия (996)312-96-26-47

Магнитогорск (3519)55-03-13
 Москва (495)268-04-70
 Мурманск (8152)59-64-93
 Набережные Челны (8552)20-53-41
 Нижний Новгород (831)429-08-12
 Новокузнецк (3843)20-46-81
 Новосибирск (383)227-86-73
 Омск (3812)21-46-40
 Орел (4862)44-53-42
 Оренбург (3532)37-68-04
 Пенза (8412)22-31-16
 Россия (495)268-04-70

Пермь (342)205-81-47
 Ростов-на-Дону (863)308-18-15
 Рязань (4912)46-61-64
 Самара (846)206-03-16
 Санкт-Петербург (812)309-46-40
 Саратов (845)249-38-78
 Севастополь (8692)22-31-93
 Симферополь (3652)67-13-56
 Смоленск (4812)29-41-54
 Сочи (862)225-72-31
 Ставрополь (8652)20-65-13
 Казахстан (772)734-952-31

Сургут (3462)77-98-35
 Тверь (4822)63-31-35
 Томск (3822)98-41-53
 Тула (4872)74-02-29
 Тюмень (3452)66-21-18
 Ульяновск (8422)24-23-59
 Уфа (347)229-48-12
 Хабаровск (4212)92-98-04
 Челябинск (351)202-03-61
 Череповец (8202)49-02-64
 Ярославль (4852)69-52-93

<https://avx.nt-rt.ru/> || avx@nt-rt.ru