

Архангельск (8182)63-90-72
Астана (7172)727-132
Астрахань (8512)99-46-04
Барнаул (3852)73-04-60
Белгород (4722)40-23-64
Брянск (4832)59-03-52
Владивосток (423)249-28-31
Волгоград (844)278-03-48
Вологда (8172)26-41-59
Воронеж (473)204-51-73
Екатеринбург (343)384-55-89
Иваново (4932)77-34-06

Ижевск (3412)26-03-58
Иркутск (395)279-98-46
Казань (843)206-01-48
Калининград (4012)72-03-81
Калуга (4842)92-23-67
Кемерово (3842)65-04-62
Киров (8332)68-02-04
Краснодар (861)203-40-90
Красноярск (391)204-63-61
Курск (4712)77-13-04
Липецк (4742)52-20-81
Киргизия (996)312-96-26-47

Магнитогорск (3519)55-03-13
Москва (495)268-04-70
Мурманск (8152)59-64-93
Набережные Челны (8552)20-53-41
Нижний Новгород (831)429-08-12
Новокузнецк (3843)20-46-81
Новосибирск (383)227-86-73
Омск (3812)21-46-40
Орел (4862)44-53-42
Оренбург (3532)37-68-04
Пенза (8412)22-31-16
Россия (495)268-04-70

Пермь (342)205-81-47
Ростов-на-Дону (863)308-18-15
Рязань (4912)46-61-64
Самара (846)206-03-16
Санкт-Петербург (812)309-46-40
Саратов (845)249-38-78
Севастополь (8692)22-31-93
Симферополь (3652)67-13-56
Смоленск (4812)29-41-54
Сочи (862)225-72-31
Ставрополь (8652)20-65-13
Казахстан (772)734-952-31

Сургут (3462)77-98-35
Тверь (4822)63-31-35
Томск (3822)98-41-53
Тула (4872)74-02-29
Тюмень (3452)66-21-18
Ульяновск (8422)24-23-59
Уфа (347)229-48-12
Хабаровск (4212)92-98-04
Челябинск (351)202-03-61
Череповец (8202)49-02-64
Ярославль (4852)69-52-93

<https://avx.nt-rt.ru/> || avx@nt-rt.ru



Board to Board Connector Solutions



IMPORTANT INFORMATION/DISCLAIMER

All product specifications, statements, information and data (collectively, the “Information”) in this datasheet or made available on the website are subject to change. The customer is responsible for checking and verifying the extent to which the Information contained in this publication is applicable to an order at the time the order is placed. All Information given herein is believed to be accurate and reliable, but it is presented without guarantee, warranty, or responsibility of any kind, expressed or implied.

Statements of suitability for certain applications are based on KYOCERA AVX’s knowledge of typical operating conditions for such applications, but are not intended to constitute and KYOCERA AVX specifically disclaims any warranty concerning suitability for a specific customer application or use.

ANY USE OF PRODUCT OUTSIDE OF SPECIFICATIONS OR ANY STORAGE OR INSTALLATION INCONSISTENT WITH PRODUCT GUIDANCE VOIDS ANY WARRANTY.

The Information is intended for use only by customers who have the requisite experience and capability to determine the correct products for their application. Any technical advice inferred from this Information or otherwise provided by KYOCERA AVX with reference to the use of KYOCERA AVX’s products is given without regard, and KYOCERA AVX assumes no obligation or liability for the advice given or results obtained.

Although KYOCERA AVX designs and manufactures its products to the most stringent quality and safety standards, given the current state of the art, isolated component failures may still occur. Accordingly, customer applications which require a high degree of reliability or safety should employ suitable designs or other safeguards (such as installation of protective circuitry or redundancies) in order to ensure that the failure of an electrical component does not result in a risk of personal injury or property damage.

Unless specifically agreed to in writing, KYOCERA AVX has not tested or certified its products, services or deliverables for use in high risk applications including medical life support, medical device, direct physical patient contact, water treatment, nuclear facilities, weapon systems, mass and air transportation control, flammable environments, or any other potentially life critical uses. Customer understands and agrees that KYOCERA AVX makes no assurances that the products, services or deliverables are suitable for any high-risk uses. Under no circumstances does KYOCERA AVX warrant or guarantee suitability for any customer design or manufacturing process.

Although all product-related warnings, cautions and notes must be observed, the customer should not assume that all safety measures are indicated or that other measures may not be required.

Board to Board Connector Solutions

Table of Contents

TWO PIECE

Horizontal Plug: 10-9159-BTB

General Description.....	2
2 Position.....	3
3 Position.....	4
4 Position.....	5
5 Position.....	6
6 Position.....	7
Accessory Retaining Clip/Plug Assembly/Mated Assembly/Hand Insertion Tool.....	8

Solder Cup Plug: 11-9159-WTB

General Description.....	9
2 Position.....	10
3 Position.....	11
4 Position.....	12
5 Position.....	13
6 Position.....	14
Cover Accessory.....	15
Latch Accessory.....	16
Accessory Ordering Codes / 3 Assembled Options.....	17

Vertical Plug: 13-9159-BTB

General Description.....	18
2 Position.....	19
3 Position.....	20
4 Position.....	21
5 Position.....	22
6 Position.....	23

IDC Plug: 14-9159-WTB

General Description.....	24
2 Position Through Wire Cap.....	25
3 Position Through Wire Cap.....	26
4 Position Through Wire Cap.....	27
5 Position Through Wire Cap.....	28
6 Position Through Wire Cap.....	29
2 Position Wire Stop Cap.....	30
3 Position Wire Stop Cap.....	31
4 Position Wire Stop Cap.....	32
5 Position Wire Stop Cap.....	33
6 Position Wire Stop Cap.....	34
Assembly Support Block / Insertion Tool.....	35
Assembly.....	36

Horizontal Socket: 20-9159-BTB

General Description.....	37
2 Position.....	38
3 Position.....	39
4 Position.....	40
5 Position.....	41
6 Position.....	42

Top Load Socket: 22-9159-BTB

General Description.....	43
2 Position.....	44

3 Position.....	45
4 Position.....	46
5 Position.....	47
6 Position.....	48
Assembly.....	49

IDC Socket: 24-9159 WTB

General Description.....	50
2 Position Through Wire Cap.....	51
3 Position Through Wire Cap.....	52
4 Position Through Wire Cap.....	53
5 Position Through Wire Cap.....	54
6 Position Through Wire Cap.....	55
2 Position Wire Stop Cap.....	56
3 Position Wire Stop Cap.....	57
4 Position Wire Stop Cap.....	58
5 Position Wire Stop Cap.....	59
6 Position Wire Stop Cap.....	60
Assembly Support Block, Insertion Tool.....	61
Assembly.....	62

Shorting Socket: 58-9159-BTB

General Description.....	63
--------------------------	----

Single 2 Piece Contacts: 70-9159-BTB

General Description.....	65
401 Plug.....	66
402 Socket.....	67
411 Locking Plug Contact.....	68
Contact Solder Tolerance.....	69
Board to Board Assembly.....	70
Simple Compact Wired Plug Assemblies.....	71

ONE PIECE CARD EDGE

Standard Card Edge: 00-9159-BTB

General Description.....	73
2 Position.....	74
3 Position.....	75
4 Position.....	76
5 Position.....	77

Open Ended Card Edge: 00-9159-BTB

General Description.....	78
4 Position.....	79
6 Position.....	80
8 Position.....	81
10 Position.....	82

Inverted Thru Board Card Edge: 00-9159-BTB

General Description.....	83
2 Position.....	84
3 Position.....	85
4 Position.....	86
5 Position.....	87
6 Position.....	88
Thru Board Mating Edge Card Connector – With Cap.....	89

Board to Board Connector Solution

Table of Contents

Thru Board Mating Edge Card Connector – Mating PCB	90	4mm High Pin	132
Assembly	91	5mm High Pin	133
Accessory – Protection Cap	92	PCB Details	134
Vertical Top Entry Card Edge: 00-9159-BTB			
General Description	93		
2 Position	94		
3 Position	95		
4 Position	96		
5 Position	97		
6 Position	98		
Top Mounting Edge Card Connector – Mating PCB	99		
Assembly	100		
ONE PIECE COMPRESSION			
Ultra-Low Profile 2.5mm Pitch Battery-9155-100			
General Description	102		
2 Position – No Stop	103		
3 Position – No Stop	104		
2 Position – With Stop	105		
3 Position – With Stop	106		
Low Profile Mating Pads	107		
Low Profile Single Contact-70-9155			
General Description	108		
Height 1.00mm	109		
Height 1.50mm	110		
Dual Row Stacker: BTB-00-9158			
General Description	111		
2.0mm Without Bosses	112		
2.5mm Without Bosses	113		
3.0mm Without Bosses	114		
2.0mm With Bosses	115		
2.5mm With Bosses	116		
3.0mm With Bosses	117		
Limits to PBC Misalignment & Packing Details	118		
Staggered Stacker: 00-9188-BTB			
General Description	119		
4 Position 1.2mm	120		
4 Position 2.0mm	121		
6 Position 2.0mm	122		
8 Position 2.0mm	123		
Ultra Low Profile Stacker: 00-9258-BTB			
General Description	124		
0.4mm	125		
0.8mm	126		
POGO PIN COMPRESSION			
Pogo Pin Single Contact: 70-9150-BTB			
General Description	128		
2mm High Pin	129		
2.5mm High Pin	130		
3mm High Pin	131		
BOARD TO BOARD JUMPER			
Jumper: 10-9296 BTB			
General Description	136		
LINKING			
Linking Contact System: 70-9159 BTB			
General Description	142		
Low Profile High Current & Bridge Contact	143		

Horizontal Plug: 10-9159-BTB

General Description



The 9159 series of Board-to-Board interconnect system allows two PCB's to be mated end-to-end creating strips of LED lighting. Designed specifically for the unique Solid State Lighting (SSL) market requiring coplanar (horizontal-to-horizontal) PCB mating with a 5 Amp current rating in the smallest package available. These single sided SMT connectors are perfect for both FR4 and metal boards where you need to butt the boards up together to minimize separation. Availability of both white and black insulation colors make them perfect for lighting as well as industrial applications. With sizes from 2p-6p, these high reliability connectors boast gold plated beryllium copper receptacle contacts for harsh environments.

APPLICATIONS

- Coplanar PCB mating in SSL products
- LED linear lighting strips
- Application Notes: refer to 201-01-123

FEATURES AND BENEFITS

- Single sided SMT: supports FR4 and metal PCB's
- 5 Amp current rating: exceeds general market needs
- 5.5mm mated width: minimizes PCB space to decrease LED pitch
- Gold plated BeCu spring contacts: reliability for harsh environments
- Optional retaining clip: provides positive connector mating during vibration
- Available in white: supports SSL market preferences

ELECTRICAL

- Current Rating: 5 Amps / Contact
- Voltage Rating: 125 VAC

ENVIRONMENTAL

- Operating Temperature: -40°C to +125°C

MECHANICAL

- Insulator Material: Nylon: VL94VO
- Contact Material: BeCu / Phos Bronze
- Plating: Gold / Tin over Nickel
- Durability: 10 Cycles

HOW TO ORDER

10

Plug

9159

Series

00X

Number of Ways

Code	No of Ways	Details
002	2	Page 3
003	3	Page 4
004	4	Page 5
005	5	Page 6
006	6	Page 7

Optional Retaining Clip
Page 8

1

2 Part
PCB Strip
Connector

01

Connector
Pitch
01 = 3mm

9

Color/Approva

Code	Color	Approval
9	White	UL Approved

16

Plating Option

Code	Contact	Bracket
16	Gold in Contact Area Tin on Solder Tail	Tin all over



Certification: UL File #E90723

Horizontal Plug: 10-9159-BTB

2 Position

PLUG 2 WAY 2 PART PCB STRIP CONNECTOR

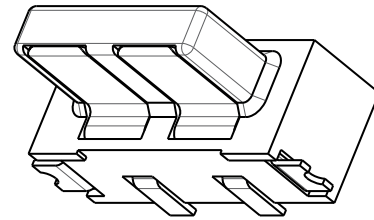
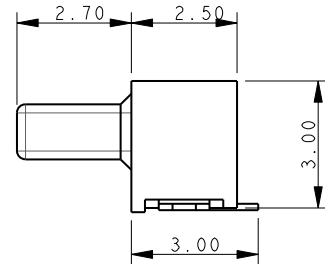
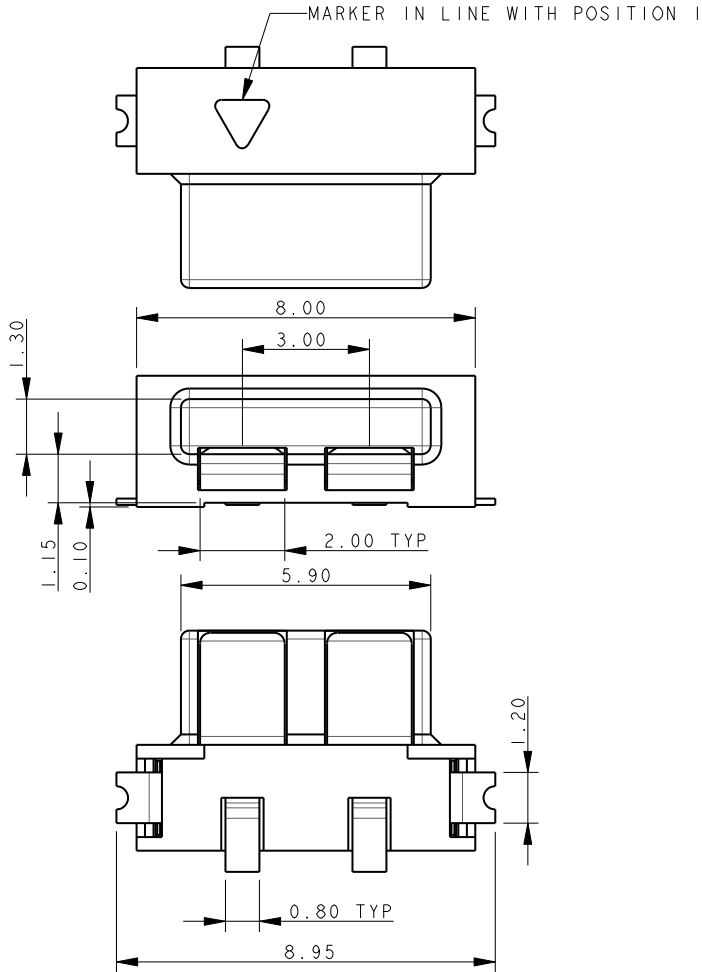

NOTES:

1. FOR MORE INFORMATION REFER TO PRODUCT SPEC 201-01-119.
2. DIMENSIONS ARE REFERENCE DIMENSIONS UNLESS TOLERANCES.
3. INSULATOR MATERIAL: NYLON 46.
4. CONTACT MATERIAL: COPPER ALLOY, SELECTIVE GOLD OVER NICKEL TIN PLATED ON TAILS.
5. BRACKETS: COPPER ALLOY, TIN PLATED.
6. OUTLINE OF CONNECTOR.
7. PACKING TAPE AND REEL, QUANTITY 1400 PER REEL.
8. OPTIONAL RETAINING CLIP, SEE PAGE 8.

2 WAY PCB BOARD LAYOUT

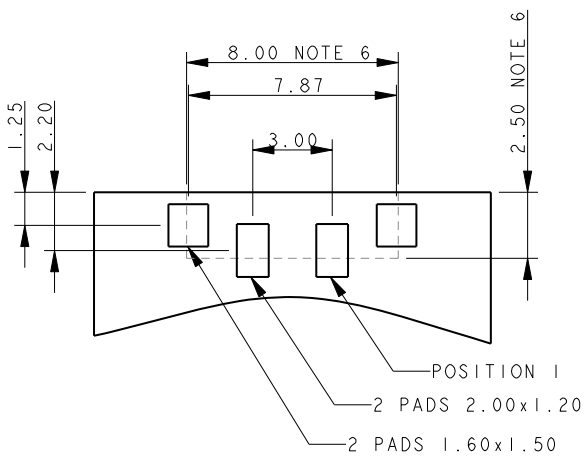

PACKING DETAILS

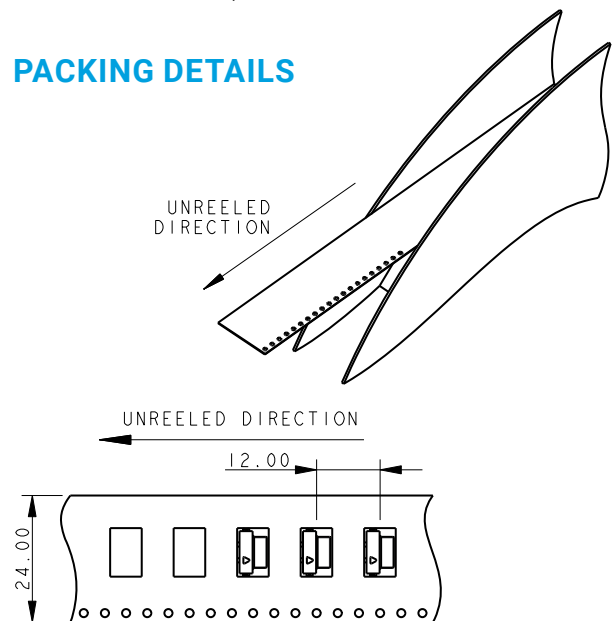

Horizontal Plug: BTB

3 Position

PLUG 3 WAY 2 PART PCB STRIP CONNECTOR

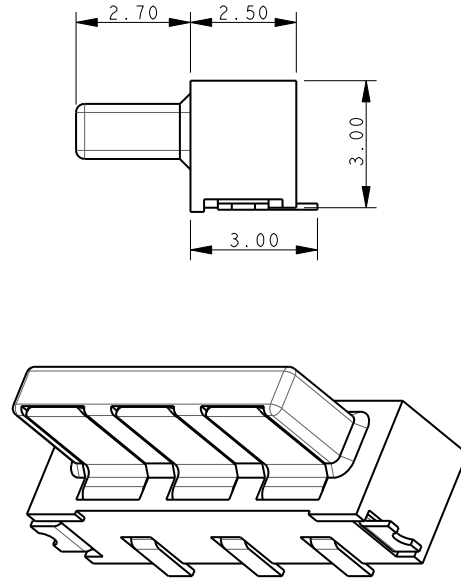
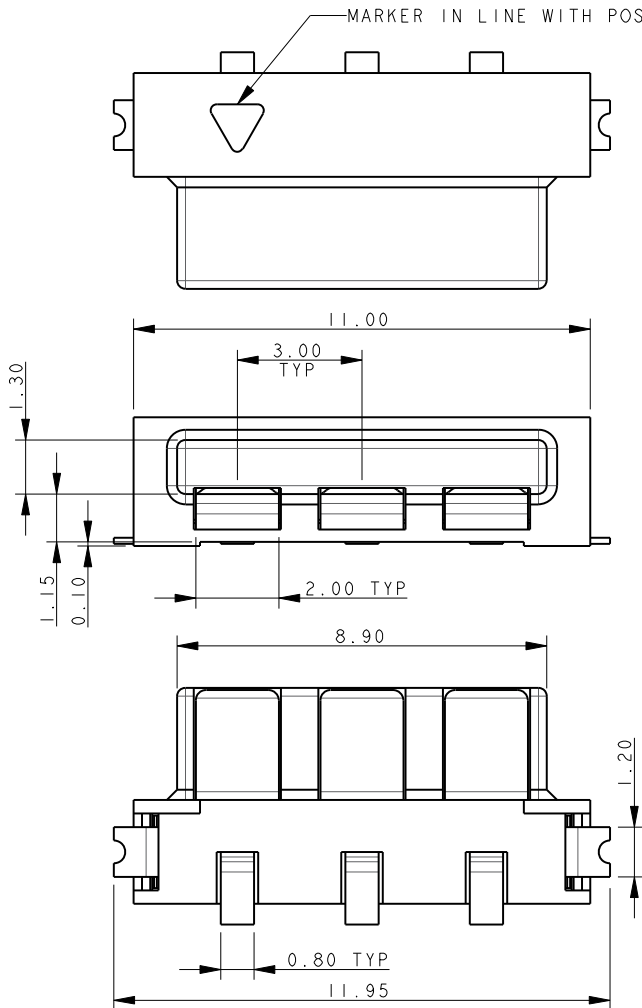

NOTES:

1. FOR MORE INFORMATION REFER TO PRODUCT SPEC 201-01-119.
2. DIMENSIONS ARE REFERENCE DIMENSIONS UNLESS TOLERANCES.
3. INSULATOR MATERIAL: NYLON 46.
4. CONTACT MATERIAL: COPPER ALLOY, SELECTIVE GOLD OVER NICKEL TIN PLATED ON TAILS.
5. BRACKETS: COPPER ALLOY, TIN PLATED.
6. OUTLINE OF CONNECTOR.
7. PACKING TAPE AND REEL, QUANTITY 1400 PER REEL.
8. OPTIONAL RETAINING CLIP, SEE PAGE 8.

3 WAY PCB BOARD LAYOUT

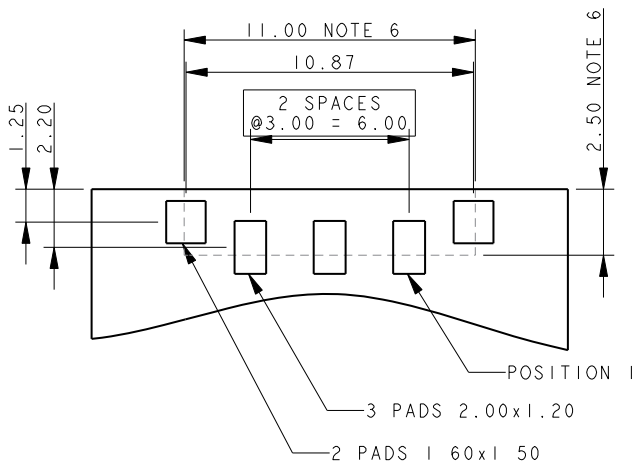

PACKING DETAILS

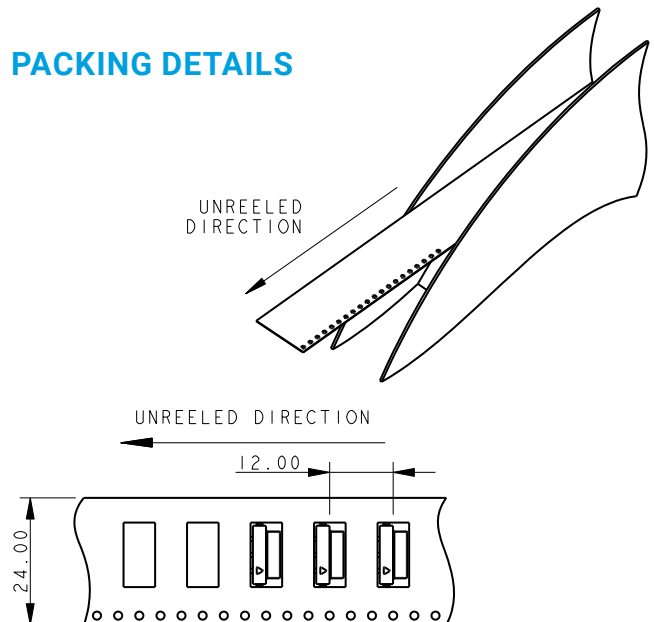

Horizontal Plug: 10-9159-BTB

4 Position

PLUG 4 WAY 2 PART PCB STRIP CONNECTOR

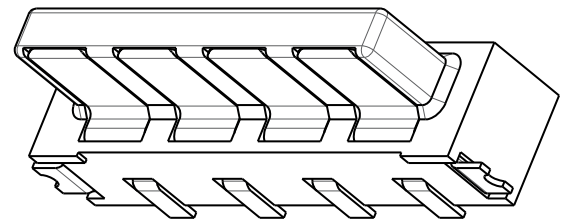
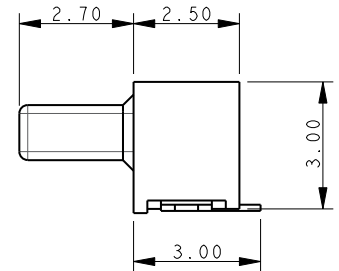
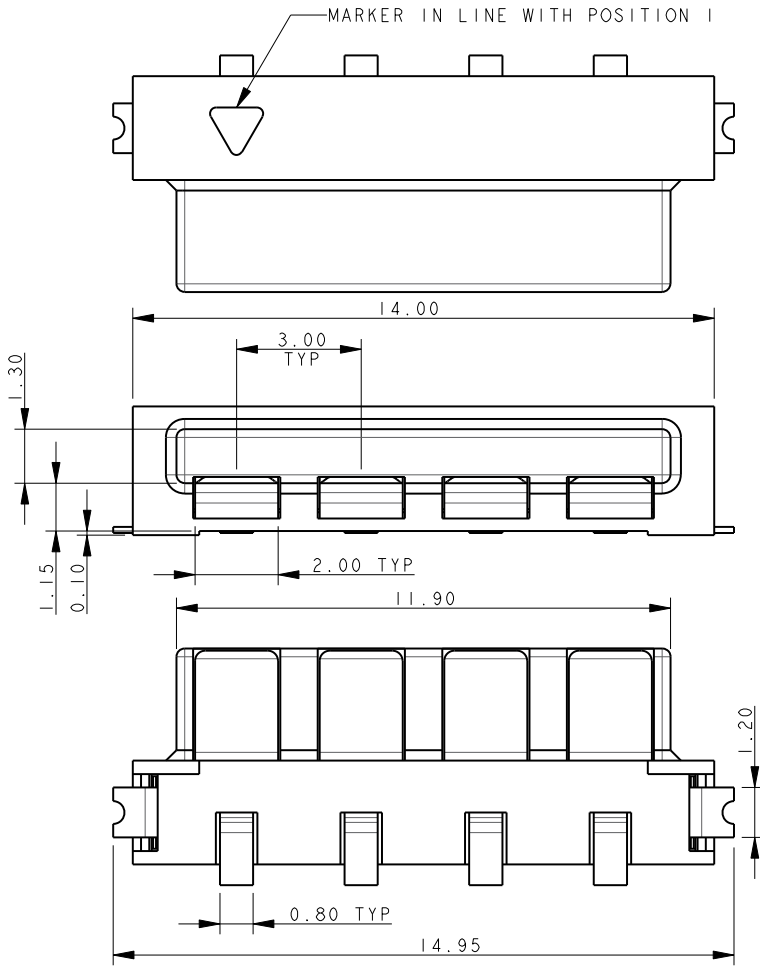

NOTES:

1. FOR MORE INFORMATION REFER TO PRODUCT SPEC 201-01-119.
2. DIMENSIONS ARE REFERENCE DIMENSIONS UNLESS TOLERANCES.
3. INSULATOR MATERIAL: NYLON 46.
4. CONTACT MATERIAL: COPPER ALLOY, SELECTIVE GOLD OVER NICKEL TIN PLATED ON TAILS.
5. BRACKETS: COPPER ALLOY, TIN PLATED.
6. OUTLINE OF CONNECTOR.
7. PACKING TAPE AND REEL, QUANTITY 1400 PER REEL.
8. OPTIONAL RETAINING CLIP, SEE PAGE 8.

4 WAY PCB BOARD LAYOUT

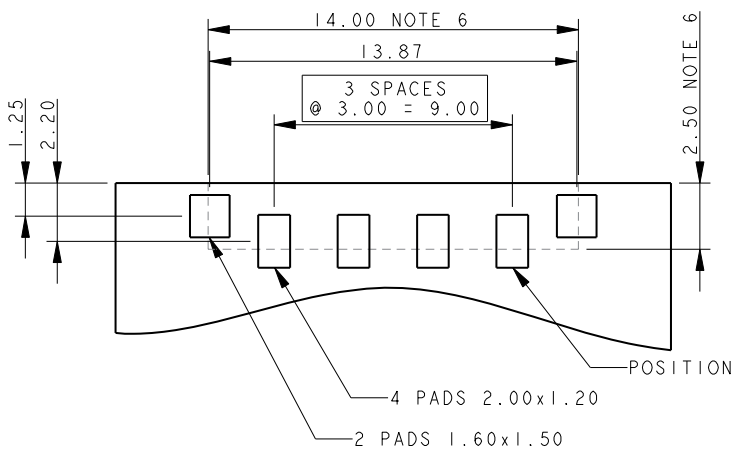

PACKING DETAILS

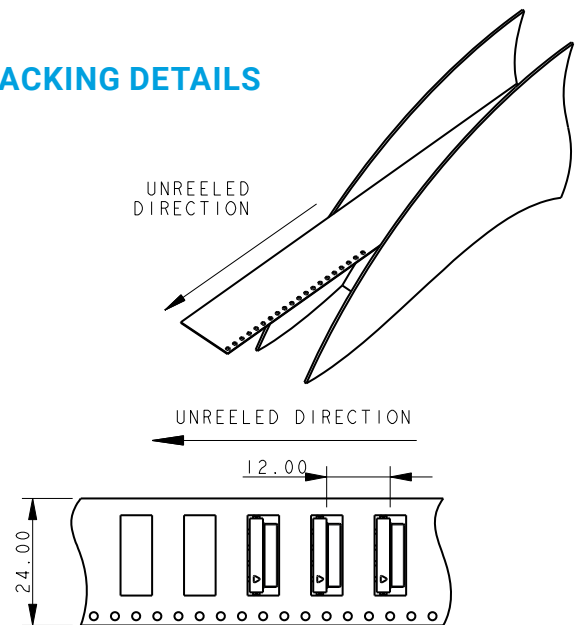

Horizontal Plug: 10-9159-BTB

5 Position

PLUG 5 WAY 2 PART PCB STRIP CONNECTOR

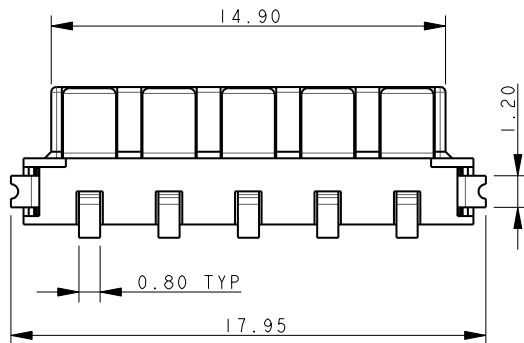
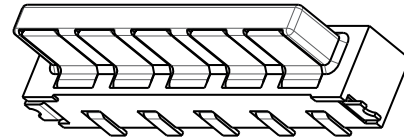
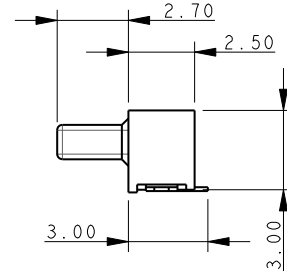
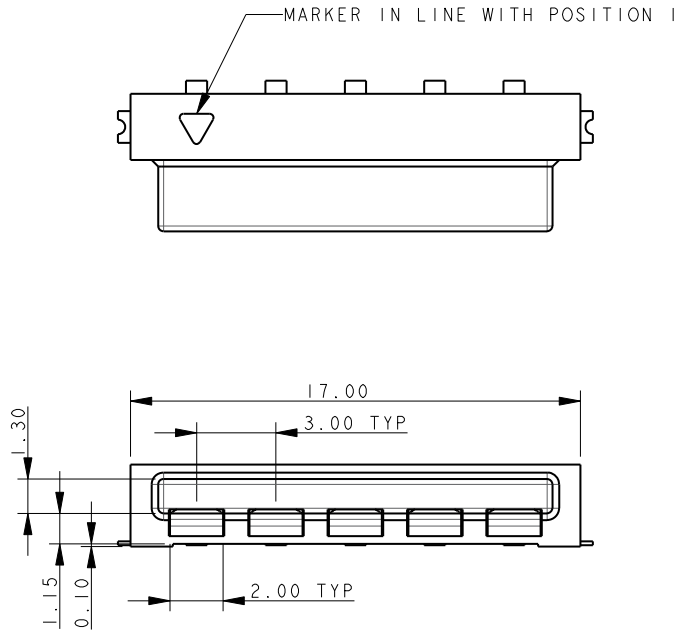

NOTES:

1. FOR MORE INFORMATION REFER TO PRODUCT SPEC 201-01-119.
2. DIMENSIONS ARE REFERENCE DIMENSIONS UNLESS TOLERANCES.
3. INSULATOR MATERIAL: NYLON 46.
4. CONTACT MATERIAL: COPPER ALLOY, SELECTIVE GOLD OVER NICKEL TIN PLATED ON TAILS.
5. BRACKETS: COPPER ALLOY, TIN PLATED.
6. OUTLINE OF CONNECTOR.
7. PACKING TAPE AND REEL, QUANTITY 1400 PER REEL.
8. OPTIONAL RETAINING CLIP, SEE PAGE 8.

5 WAY PCB BOARD LAYOUT

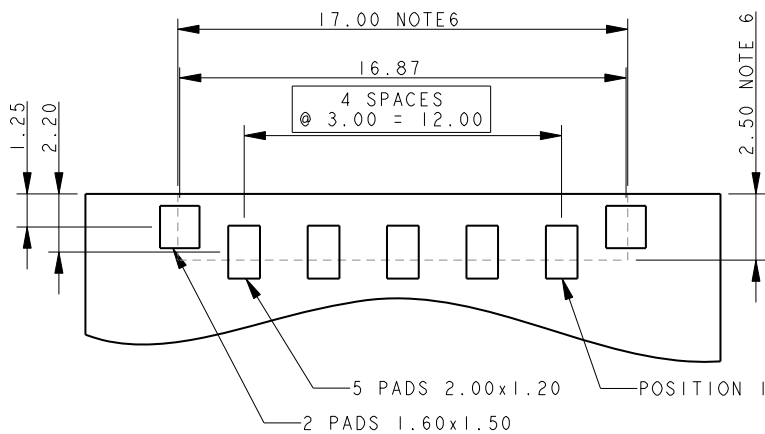

PACKING DETAILS

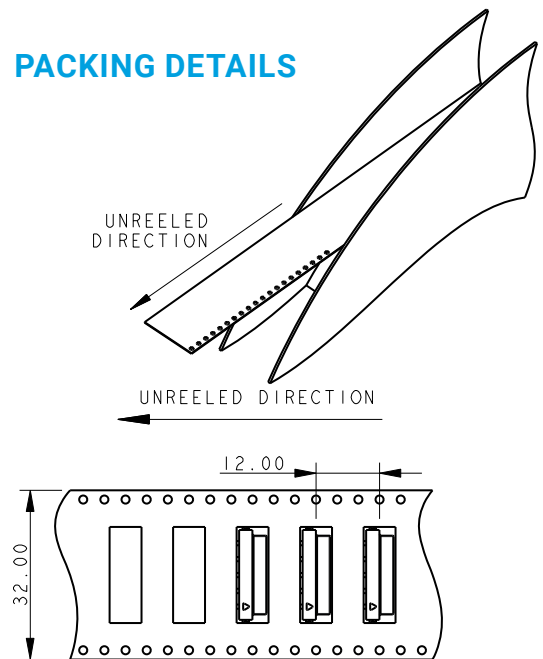

Horizontal Plug: 10-9159-BTB

6 Position

PLUG 6 WAY 2 PART PCB STRIP CONNECTOR

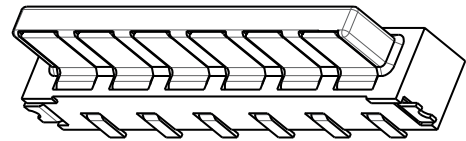
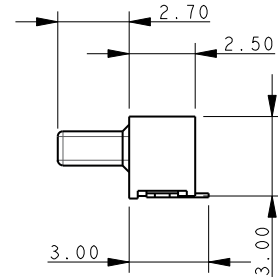
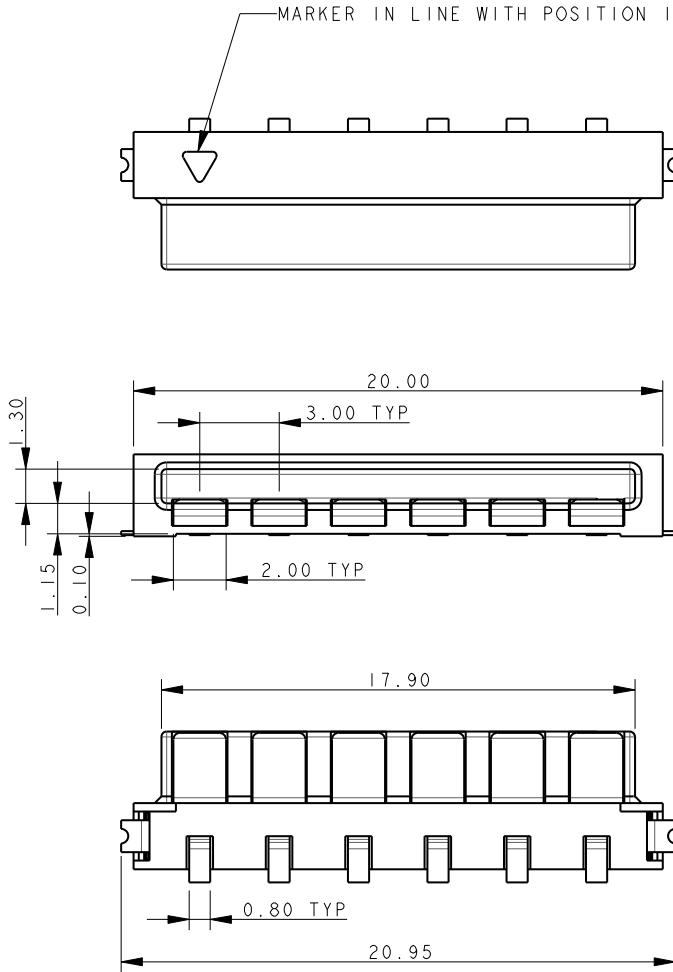

NOTES:

1. FOR MORE INFORMATION REFER TO PRODUCT SPEC 201-01-119.
2. DIMENSIONS ARE REFERENCE DIMENSIONS UNLESS TOLERANCES.
3. INSULATOR MATERIAL: NYLON 46.
4. CONTACT MATERIAL: COPPER ALLOY, SELECTIVE GOLD OVER NICKEL TIN PLATED ON TAILS.
5. BRACKETS: COPPER ALLOY, TIN PLATED.
6. OUTLINE OF CONNECTOR.
7. PACKING TAPE AND REEL, QUANTITY 1400 PER REEL.
8. OPTIONAL RETAINING CLIP, SEE PAGE 8.

6 WAY PCB BOARD LAYOUT

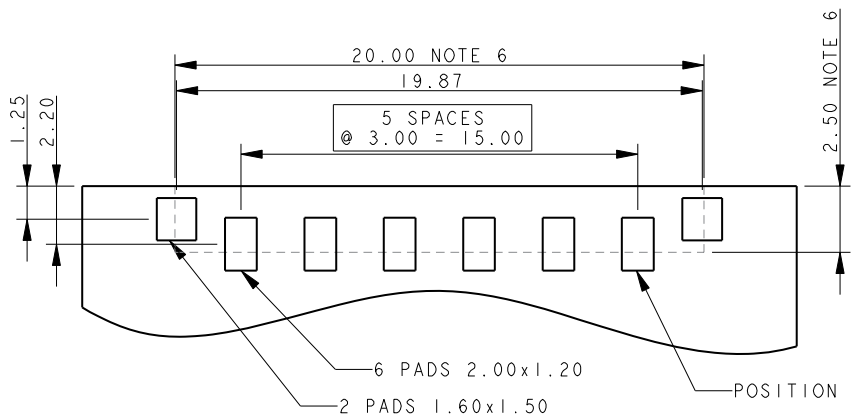

PACKING DETAILS

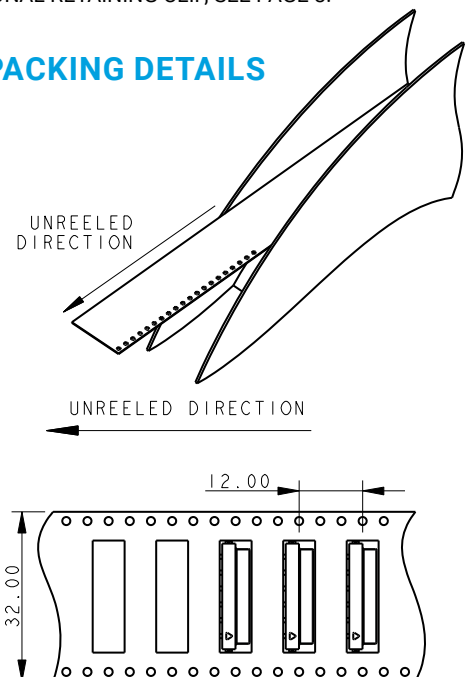

Horizontal Plug: 10-9159-BTB

Accessory Retaining Clip/Plug Assembly/Mated Assembly/Hand Insertion Tool

80-9159-4200-00-000 ACCESSORY RETAINING CLIP

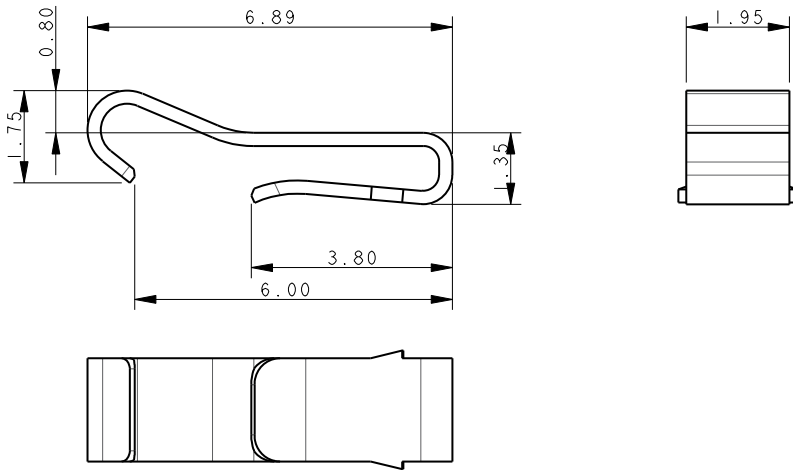

PLUG ASSEMBLY FOR REFERENCE ONLY

CLIP INSERTED INTO
10-9159-00X-101-X06

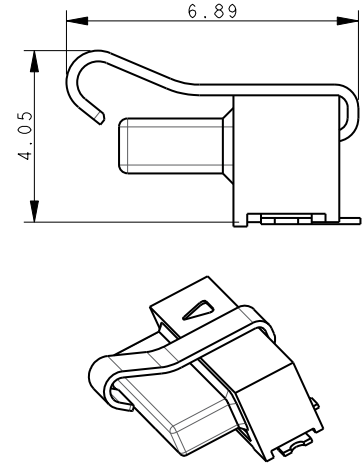

MATED ASSEMBLY – FOR REFERENCE ONLY

10-9159-00X-101-X06 MATED WITH 20-9159-00X-X06

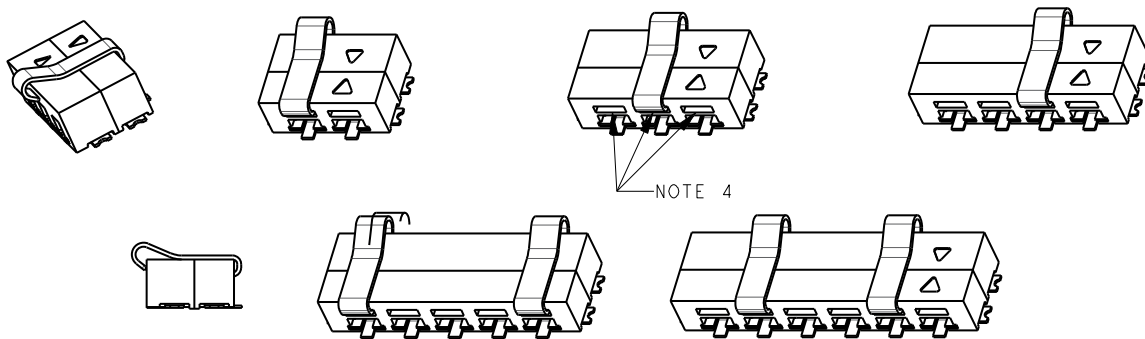

Description	# of Positions	Part Number	UL File #
Horizontal Plug w/pre-installed locking clip	2	58 9159 002 000 015	E90723
Horizontal Plug w/pre-installed locking clip	3	58 9159 003 000 015	E90723
Horizontal Plug w/pre-installed locking clip	4	58 9159 004 000 015	E90723
Horizontal Plug w/pre-installed locking clips	5	58 9159 005 000 015	E90723
Horizontal Plug w/pre-installed locking clips	6	58 9159 006 000 015	E90723

NOTES:

1. CLIP TO RETAIN MATED PAIR PLUG AND SOCKET.
2. MATERIAL: STAINLESS STEEL.
3. TAIL INSERTED INTO SLOT OF 9159 2 PART PLUG (10-9159-00X-101-006). LEADING EDGE CLIPS OVER SOCKET.
4. ALL DIMENSIONS SHOWN ARE REFERENCE DIMENSIONS.
5. RECOMMENDED 1 CLIP IN 2, 3 AND 4 WAY. 2 CLIPS IN 5 AND 6 WAY. POSITIONS AT CUSTOMER DISCRETION.

Solder Cup Plug: 11-9159-WTB

General Description

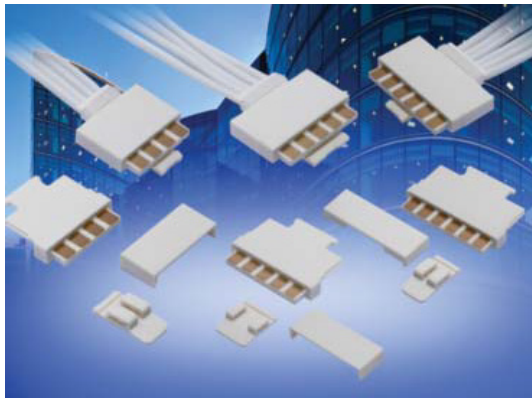

The 9159 series of Board-to-Board interconnect system allows two PCB's to be mated end-to-end creating strips of LED lighting. Designed specifically for the unique Solid State Lighting (SSL) market requiring coplanar (horizontal-to-horizontal) PCB mating with a 5 Amp current rating in the smallest package available. The cabled plug was developed to bring power and signals onto the PCB's while keeping the same board level interface. This allows the designer to build a single PCB with a receptacle on one end and a plug on the other end to minimize cost and inventory. Regardless of where the PCB is used in the system, the cabled plug connector will then create the connection to the outside world. The optional latch can be inserted into the plug housing to assure positive attachment to the PCB in harsh environments without having to change the PCB connector.

APPLICATIONS

- Provided Wire-to-Board capabilities to standard 9159 2-Piece connector system
- Application Notes: refer to 201-01-123

FEATURES AND BENEFITS

- Mates with standard horizontal socket: no need to change any connectors
- 5 Amp current rating: exceeds general market needs
- Wires are soldered into connector with tie wrap strain relief: simplicity
- Optional latch: provides positive attachment to PCB connector

ELECTRICAL

- Current Rating: 5 Amps / Contact
- Voltage Rating: 125 VAC

ENVIRONMENTAL

- Operating Temperature: -40°C to +125°C

MECHANICAL

- Insulator Material: Nylon: VL94V0
- Contact Material: BeCu / Phos Bronze
- Plating: Gold / Tin over Nickel
- Durability: 10 Cycles

HOW TO ORDER

11
Prefix
Wire Plug
Soldered
Terminations

9159
Series

00X
Number of Ways

Code	No of Ways	Details
002	2	Page 10
003	3	Page 11
004	4	Page 12
005	5	Page 13
006	6	Page 14

Optional Cover
See page 15 for ordering code

Optional Latch
See page 16 for ordering code

1
2 Part
PCB Strip
Connector

01
Connector
Pitch
01 = 3mm

9
Color/Approva

Code	Color	Approval
9	White	UL Approved

16
Plating Option

Code	Contact
16	Gold in Contact Area Tin on Solder Tail



NOTES: Connectors are supplied with cable ties (see page 17).
Covers/Latches are sold separately (see pages 15-16 for ordering codes).

Certification: UL File #E90723

Solder Cup Plug: 11-9159-WTB

2 Position

PLUG WIRED 2 WAY 2 PART 9159 LIGHTING CONNECTOR

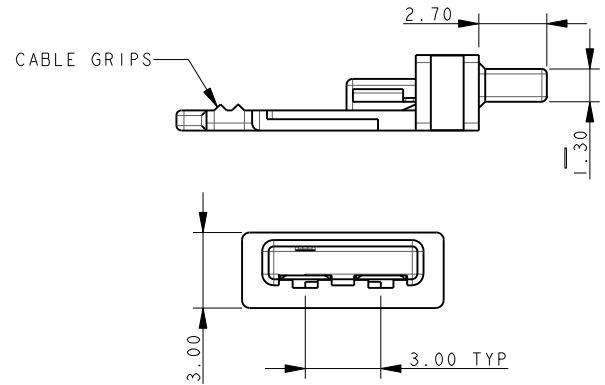
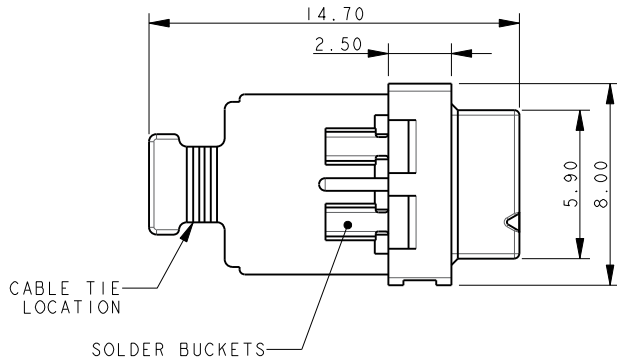

NOTES:

1. FOR MORE INFORMATION REFER TO PRODUCT SPEC 201-01-119.
2. CABLE TIE SUPPLIED FOR WIRE RETENTION, ATTACHED TO EACH REEL. SPARES CAN BE ORDERED, REFER TO PAGE 17.
3. DIMENSIONS ARE REFERENCE DIMENSIONS UNLESS TOLERANCED.
4. INSULATOR MATERIAL: NYLON 46. COLOR REFER TO PAGE 9.
5. CONTACT MATERIAL: COPPER ALLOY, SELECTIVE GOLD OVER NICKEL TIN PLATED ON TAILS.
6. PACKING IN TAPE AND REEL, QUANTITY PER REEL 700.
7. FOR ACCESSORY COVERS AND LATCHES REFER TO PAGES 15 AND 16.

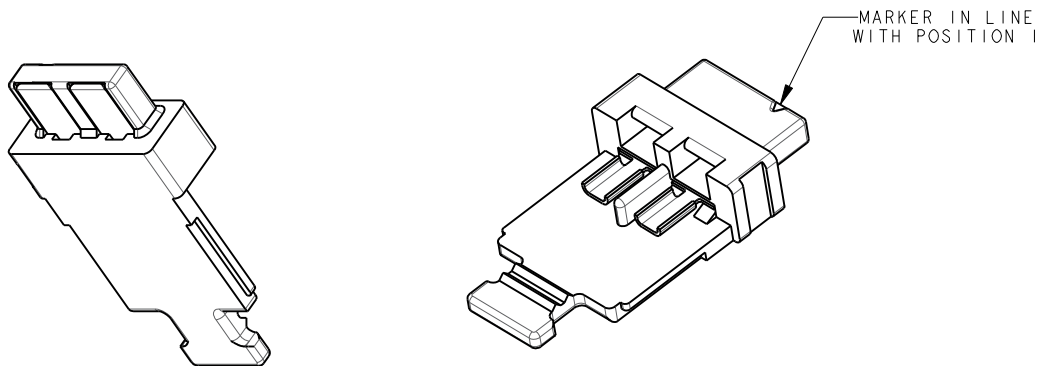

PACKING DETAILS CABLE TIES SUPPLIED WITH EACH REEL

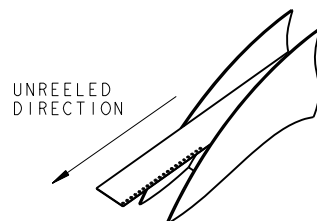
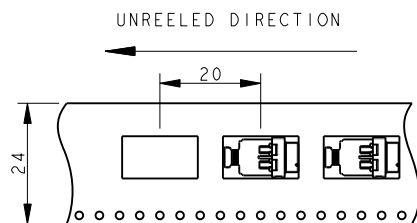

Solder Cup Plug: 11-9159-WTB

3 Position

PLUG WIRED 3 WAY 2 PART 9159 LIGHTING CONNECTOR

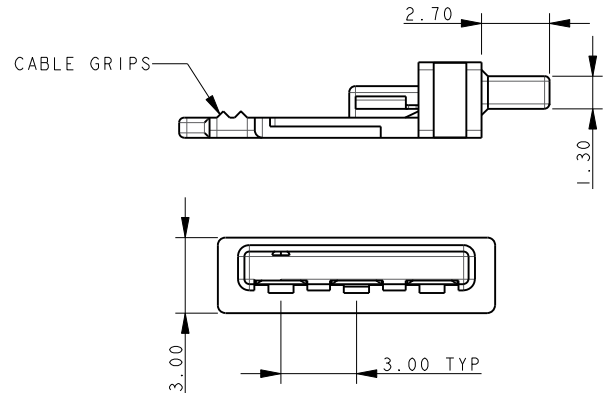
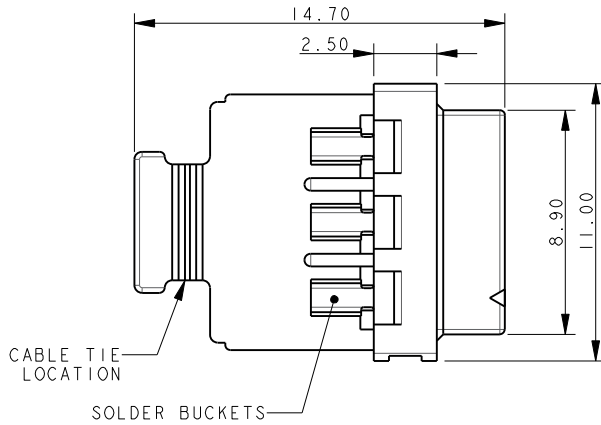

NOTES:

1. FOR MORE INFORMATION REFER TO PRODUCT SPEC 201-01-119.
2. CABLE TIE SUPPLIED FOR WIRE RETENTION, ATTACHED TO EACH REEL. SPARES CAN BE ORDERED, REFER TO PAGE 17.
3. DIMENSIONS ARE REFERENCE DIMENSIONS UNLESS TOLERANCED.
4. INSULATOR MATERIAL: NYLON 46. COLOR REFER TO PAGE 9.
5. CONTACT MATERIAL: COPPER ALLOY, SELECTIVE GOLD OVER NICKEL TIN PLATED ON TAILS.
6. PACKING IN TAPE AND REEL, QUANTITY PER REEL 700.
7. FOR ACCESSORY COVERS AND LATCHES REFER TO PAGES 15 AND 16.

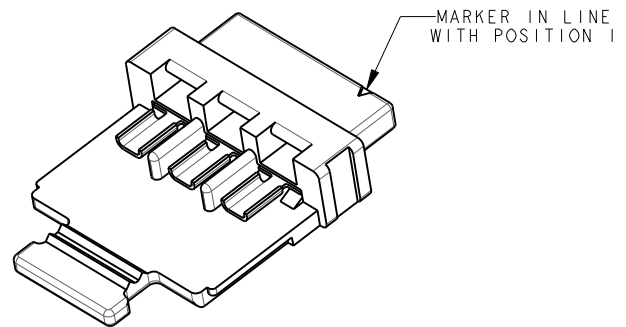
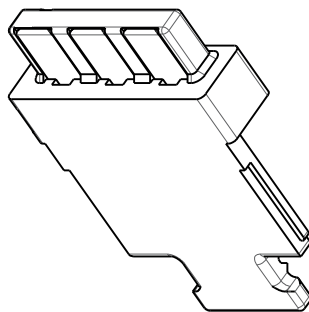

PACKING DETAILS CABLE TIES SUPPLIED WITH EACH REEL

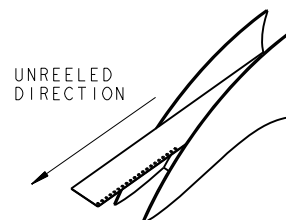
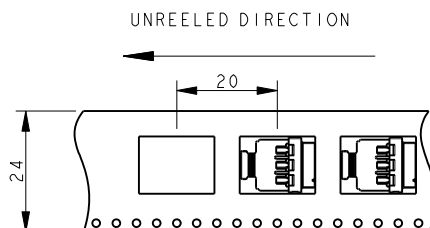

Solder Cup Plug: 11-9159-WTB

4 Position

PLUG WIRED 4 WAY 2 PART 9159 LIGHTING CONNECTOR

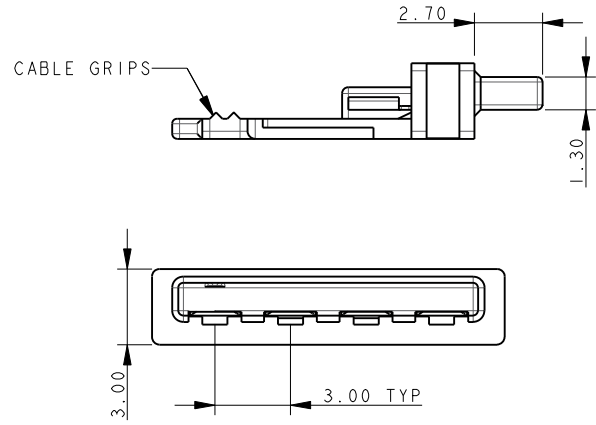
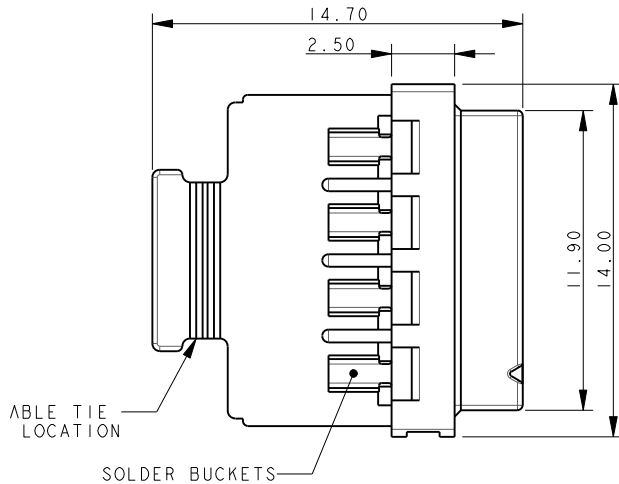

NOTES:

1. FOR MORE INFORMATION REFER TO PRODUCT SPEC 201-01-119.
2. CABLE TIE SUPPLIED FOR WIRE RETENTION, ATTACHED TO EACH REEL. SPARES CAN BE ORDERED, REFER TO PAGE 17.
3. DIMENSIONS ARE REFERENCE DIMENSIONS UNLESS TOLERANCED.
4. INSULATOR MATERIAL: NYLON 46. COLOR REFER TO PAGE 9.
5. CONTACT MATERIAL: COPPER ALLOY, SELECTIVE GOLD OVER NICKEL TIN PLATED ON TAILS.
6. PACKING IN TAPE AND REEL, QUANTITY PER REEL 700.
7. FOR ACCESSORY COVERS AND LATCHES REFER TO PAGES 15 AND 16.

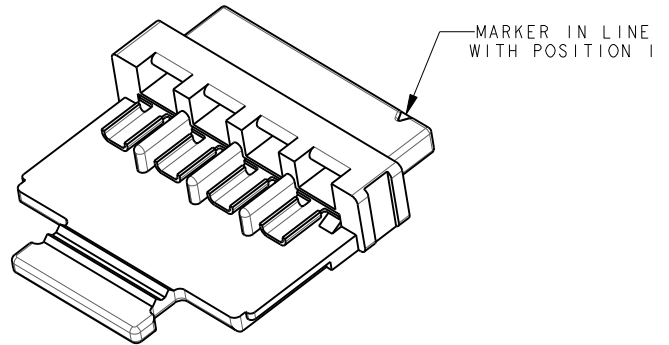
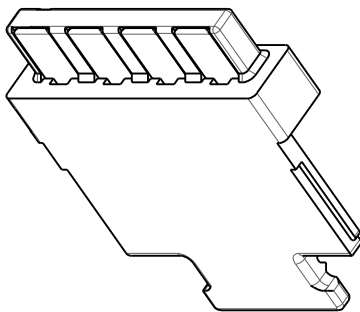

PACKING DETAILS CABLE TIES SUPPLIED WITH EACH REEL

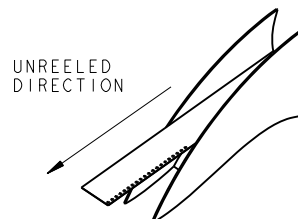
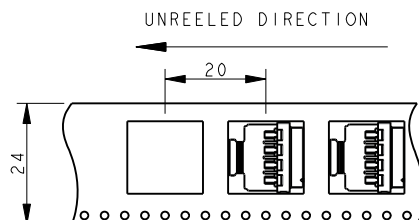

Solder Cup Plug: 11-9159-WTB

5 Position

PLUG WIRED 5 WAY 2 PART 9159 LIGHTING CONNECTOR

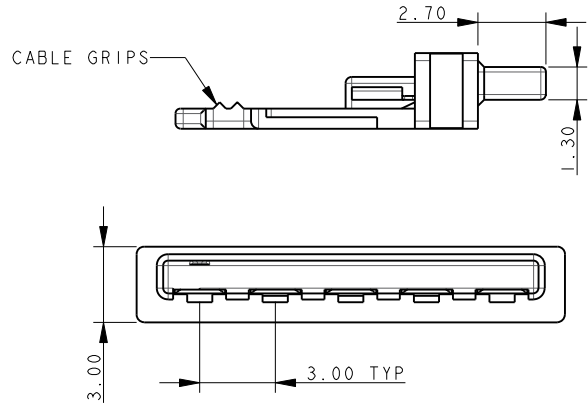
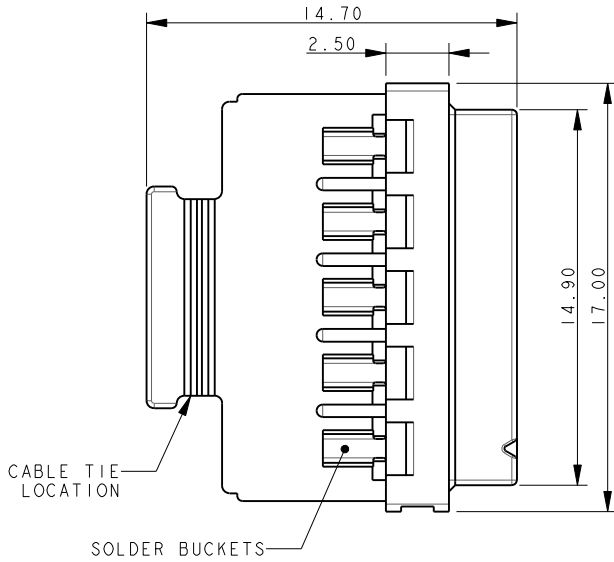

NOTES:

1. FOR MORE INFORMATION REFER TO PRODUCT SPEC 201-01-119.
2. CABLE TIE SUPPLIED FOR WIRE RETENTION, ATTACHED TO EACH REEL. SPARES CAN BE ORDERED, REFER TO PAGE 17.
3. DIMENSIONS ARE REFERENCE DIMENSIONS UNLESS TOLERANCED.
4. INSULATOR MATERIAL: NYLON 46. COLOR REFER TO PAGE 9.
5. CONTACT MATERIAL: COPPER ALLOY, SELECTIVE GOLD OVER NICKEL TIN PLATED ON TAILS.
6. PACKING IN TAPE AND REEL, QUANTITY PER REEL 700.
7. FOR ACCESSORY COVERS AND LATCHES REFER TO PAGES 15 AND 16.

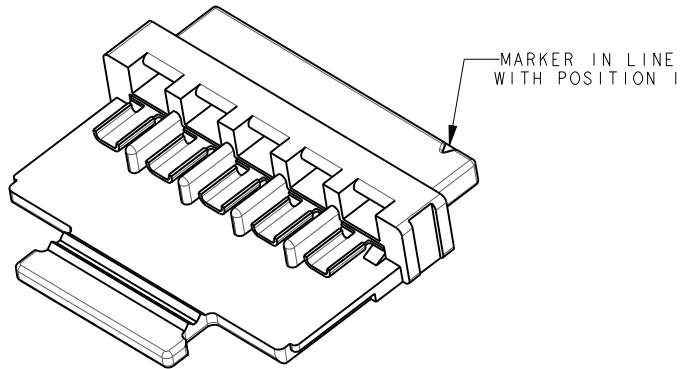
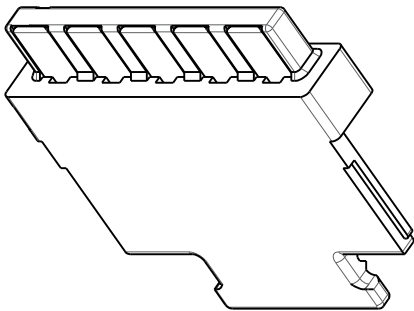

PACKING DETAILS CABLE TIES SUPPLIED WITH EACH REEL

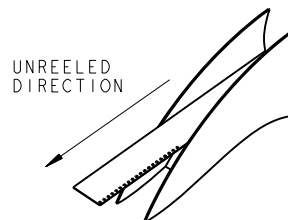
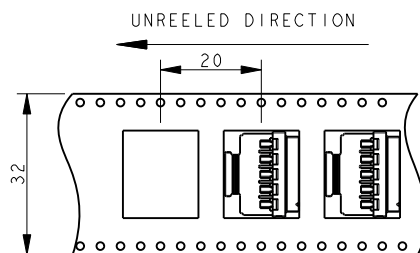

Solder Cup Plug: 11-9159-WTB

6 Position

PLUG WIRED 6 WAY 2 PART 9159 LIGHTING CONNECTOR

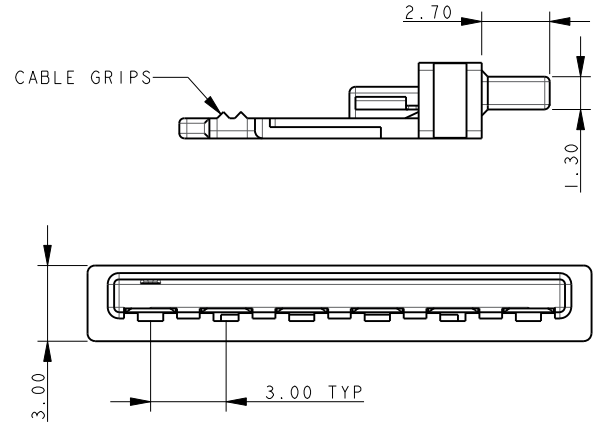
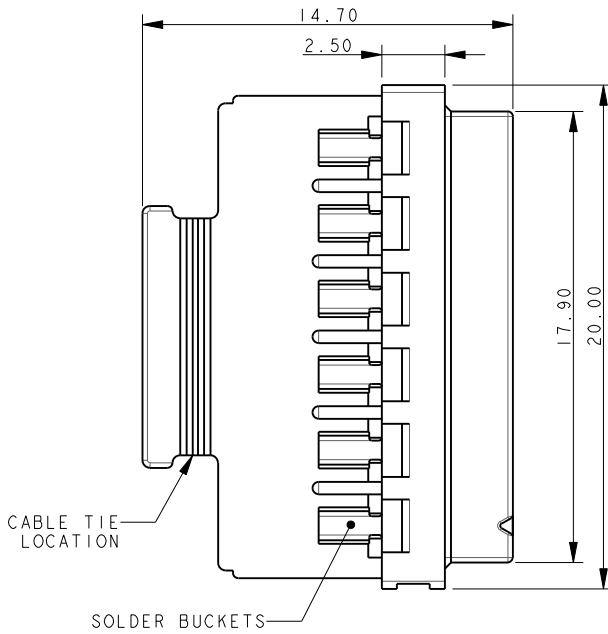

NOTES:

1. FOR MORE INFORMATION REFER TO PRODUCT SPEC 201-01-119.
2. CABLE TIE SUPPLIED FOR WIRE RETENTION, ATTACHED TO EACH REEL. SPARES CAN BE ORDERED, REFER TO PAGE 17.
3. DIMENSIONS ARE REFERENCE DIMENSIONS UNLESS TOLERANCED.
4. INSULATOR MATERIAL: NYLON 46. COLOR REFER TO PAGE 9.
5. CONTACT MATERIAL: COPPER ALLOY, SELECTIVE GOLD OVER NICKEL TIN PLATED ON TAILS.
6. PACKING IN TAPE AND REEL, QUANTITY PER REEL 700.
7. FOR ACCESSORY COVERS AND LATCHES REFER TO PAGES 15 AND 16.

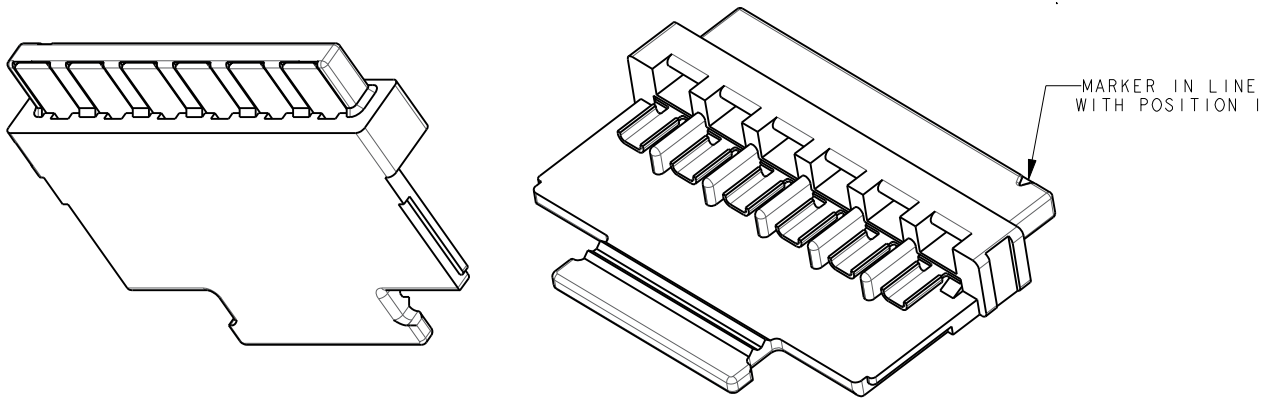

PACKING DETAILS CABLE TIES SUPPLIED WITH EACH REEL

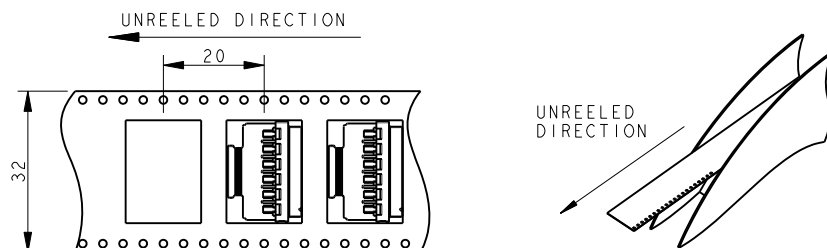

Solder Cup Plug: 11-9159-WTB

Cover Accessory

PLUG WIRED COVERS ACCESSORY NOT SUPPLIED WITH CONNECTOR ASSEMBLY

2 WAY COVER 60-9159-3302-0X-000

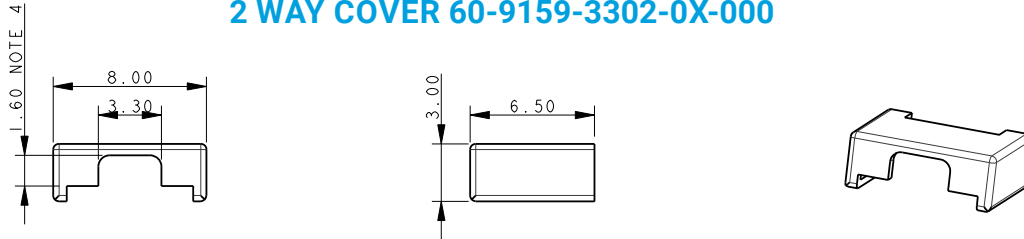

3 WAY COVER 60-9159-3303-0X-000

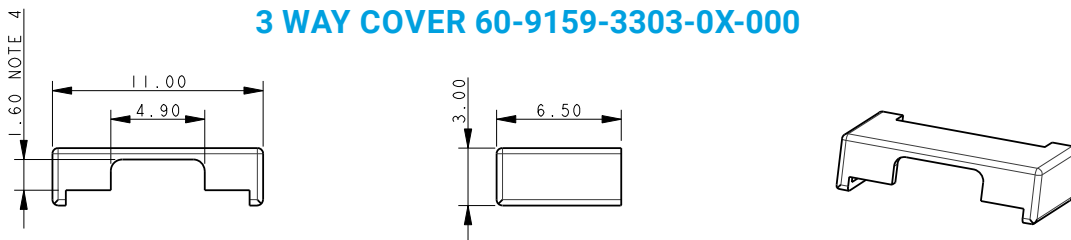

4 WAY COVER 60-9159-3304-0X-000

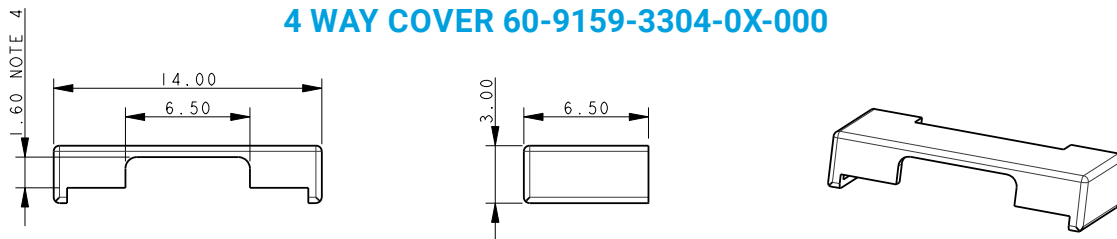

5 WAY COVER 60-9159-3305-0X-000

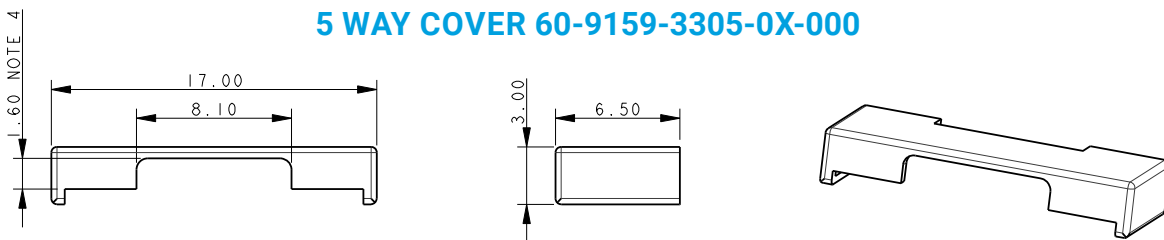

6 WAY COVER 60-9159-3306-0X-000

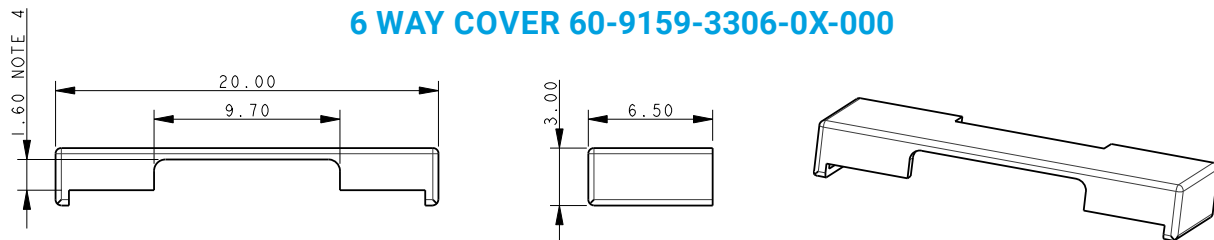

NOTES:

1. COVER (SLIDE ON) AVAILABLE TO PROTECT CABLE ENTRY.
2. OPTION COMPONENT. ORDER SEPARATELY.
3. PACKED IN BAGS, 1400 PIECES PER BAG.
4. MAXIMUM OUTER WIRE SIZE, 1.6MM DIAMETER INSULATION.
5. MATERIAL: GLASS FILLED NYLON 46. COLOR REFER TO PAGE 9.
6. COLOR OPTIONS SEE PAGE 9.
7. ALL DIMENSIONS ARE REFERENCED DIMENSIONS.
8. TO BE ASSEMBLED BEFORE CABLE TIE.

Solder Cup Plug: 11-9159-WTB

Latch Accessory

PLUG WIRED LATCHES ACCESSORY NOT SUPPLIED WITH CONNECTOR ASSEMBLY

LATCH 60-9159-3402-0X-000 USED ON 2, 4 AND 6 WAY ASSEMBLIES

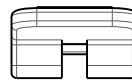
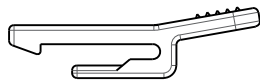
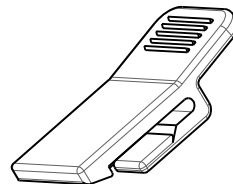
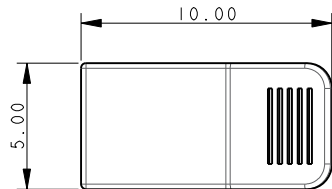

LATCH 60-9159-3403-0X-000 USED ON 3 AND 5 WAY ASSEMBLIES

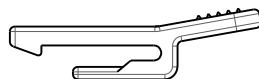
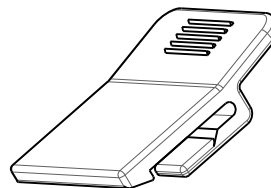
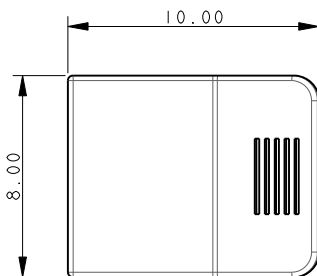

NOTES:

1. LATCH AVAILABLE TO RETAIN MATED PLUG.
2. OPTIONAL COMPONENT, ORDER SEPARATELY. SEE PAGE 17.
3. PACKAGED IN BAGS, 1400 PIECES PER BAG.
4. MATERIAL: GLASS FILLED NYLON 46. COLOR REFER TO PAGE 9.
5. ALL DIMENSIONS ARE REFERENCED DIMENSIONS.
6. TO BE ASSEMBLED BEFORE COVER.

Solder Cup Plug: 11-9159-WTB

Accessory Ordering Codes / 3 Assembled Options

PLUG WIRED ACCESSORY ORDERING CODES

Connector Assembly	Optional Components	
Part Number	Cover (see page 15)	Latch (see page 16)
11-9159-002-101-916	60-9159-3302-09-000	60-9159-3402-09-000
11-9159-003-101-916	60-9159-3303-09-000	60-9159-3403-09-000
11-9159-004-101-916	60-9159-3304-09-000	60-9159-3402-09-000
11-9159-005-101-916	60-9159-3305-09-000	60-9159-3403-09-000
11-9159-006-101-916	60-9159-3306-09-000	60-9159-3402-09-000

CABLE TIE

Supplied in bags with each reel of connector assemblies. Color White.
For additional ties order code 90-2211-7092-00-000. Packed in bags, 700 pieces per bag.

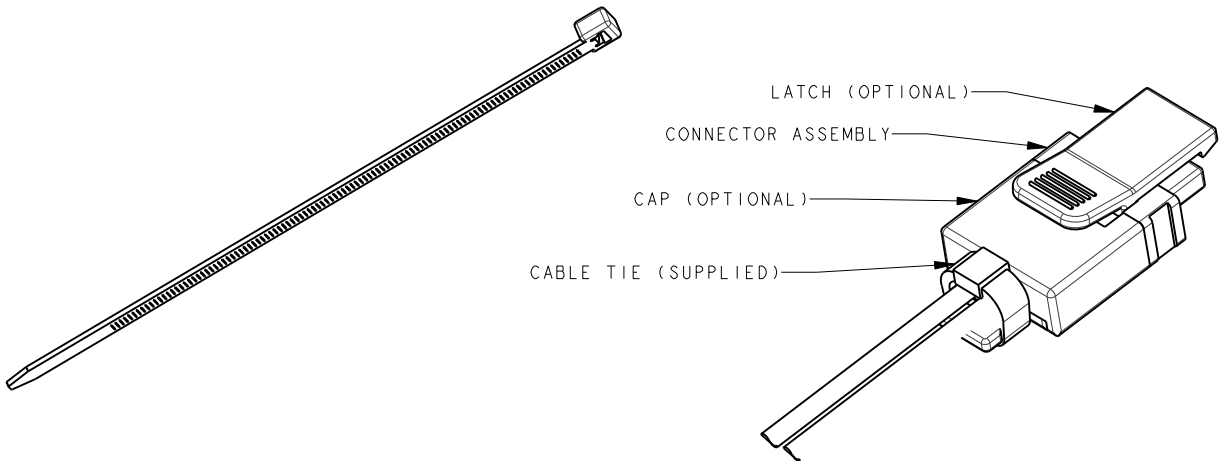

PLUG WIRED 3 ASSEMBLY OPTIONS

PLUG ASSEMBLY

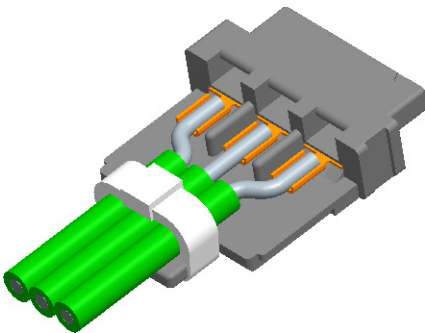

PLUG ASSEMBLY WITH COVER

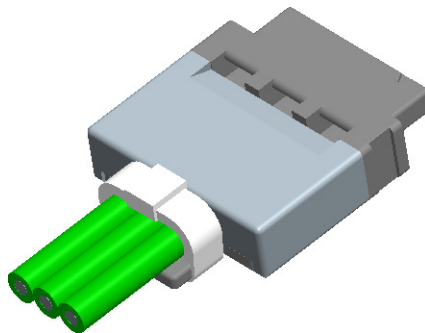

PLUG ASSEMBLY WITH COVER AND LATCH

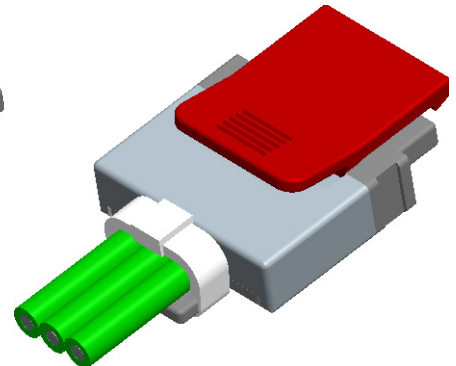

Vertical Plug: 13-9159-BTB

General Description



KYOCERA AVX developed the 9159 Series of SMT connectors for co-planar PCB mating for the challenging Solid State Lighting (SSL) market. These connectors needed to be small, low in height, carry up to 5 Amps/contact and then function up to 125C for extended periods. This application has been very unique to the SSL market where PCB's are stacked end-to-end to create linear strip lighting in everything from office to transportation applications where products are exposed to harsh mechanical and environmental environments.

This vertical plug connector opens up the spectrum to include all commercial, industrial and transportation applications requiring perpendicular PCB mating and latching Wire-to-Board cabled sockets with an already proven connector system. With sizes from 2p-6p, these gold plated contacts mate with high spring force beryllium copper receptacle connectors.

APPLICATIONS

- Allows assembly of PCB's at right angles
- Accepts 24-9159 IDC wired/cabled socket
- Reference application notes 201-01-123
- Reference Product Specification 201-01-119

FEATURES AND BENEFITS

- Single sided SMT RoHS solder attachment
- Centrally located pick & place cap for easy placement
- Gold plated BeCu contact system for high reliability in harsh environments
- Available in white: supports SSL market preferences

ELECTRICAL

- Current Rating: 5 Amps / Contact
- Voltage Rating: 125 VAC

ENVIRONMENTAL

- Operating Temperature: -40°C to +125°C

MECHANICAL

- Insulator Material: Nylon: UL94VO
- Contact Material: BeCu / Phos Bronze
- Plating: Gold / Tin over Nickel
- Durability: 10 Cycles

HOW TO ORDER

13
Prefix
Plug -
Vertical
Mount

9159
Series

00X
Number of Ways

Code	No of Ways	Details
002	2	Page 19
003	3	Page 20
004	4	Page 21
005	5	Page 22
006	6	Page 23

1
2 Part
PCB Strip
Connector

01
Connector
Pitch
01 = 3mm

9
Color/Approval

Code	Color	Approval
9	White	UL Approved

16
Plating Option

Code	Contact
16	Gold in Contact Area Tin on Solder Tail
	Bracket
	Tin All Over

Certification: UL File #E90723



Vertical Plug: 13-9159-BTB

2 Position

PLUG – VERTICAL MOUNT 2 WAY 2 PART PCB STRIP CONNECTOR

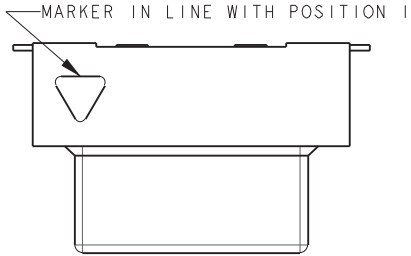

NOTES:

1. FOR FULL PRODUCT SPECIFICATION STANDARD CONNECTORS REFER TO ELCO SPEC 201-01-119, UL COMPONENTS REFER TO ELCO SPEC 201-01-119UL. FOR APPLICATION NOTES REFER TO 201-01-123.
2. GENERAL TOLERANCE ± 0.20 UNLESS TOLERANCED.
3. INSULATOR MATERIAL: NYLON 46, UL94 V-0, COLOR REFER TO PAGE 18.
4. CONTACT MATERIAL: COPPER ALLOY, SELECTIVE GOLD OVER NICKEL, TIN PLATE ON TAILS.
5. BRACKETS: COPPER ALLOY, TIN PLATED.
6. OUTLINE OF CONNECTOR.
7. PACKING IN TAPE AND REEL, QUANTITY PER REEL 700.
8. PICK AND PLACE CAP TO BE REMOVED AFTER USE.
9. OPTIONAL SLOT: ONLY REQUIRED WHEN SOCKET HAS A LATCH, RADIUS ON ENDS OPTIONAL.

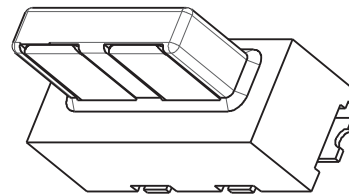
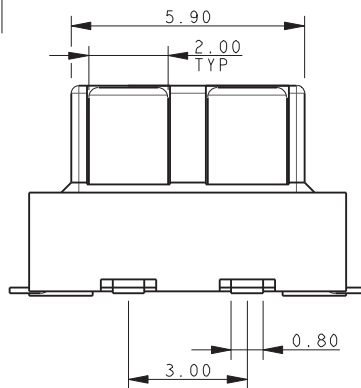
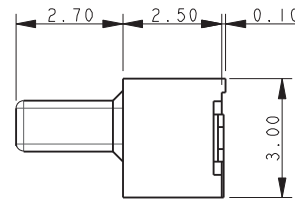
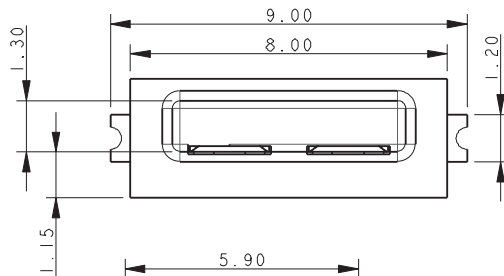

PACKING DETAILS

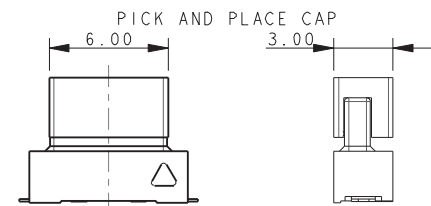

UNREELED DIRECTION

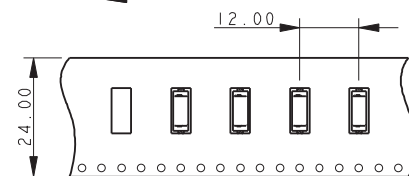

UNREELED DIRECTION

2 WAY PCB BOARD LAYOUT

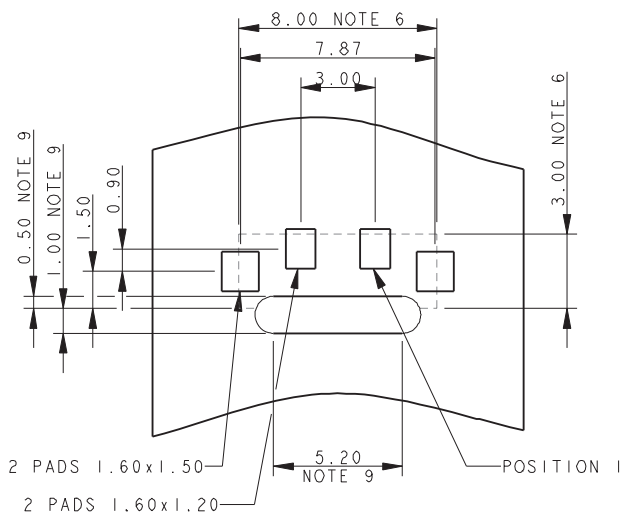

Vertical Plug: 13-9159-BTB

3 Position

PLUG – VERTICAL MOUNT 3 WAY 2 PART PCB STRIP CONNECTOR

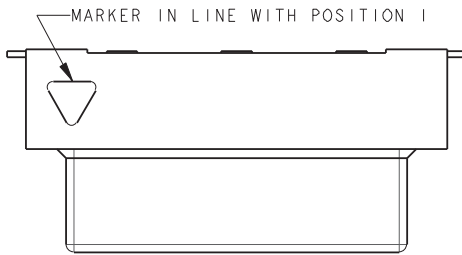

NOTES:

1. FOR FULL PRODUCT SPECIFICATION STANDARD CONNECTORS REFER TO ELCO SPEC 201-01-119, UL COMPONENTS REFER TO ELCO SPEC 201-01-119UL. FOR APPLICATION NOTES REFER TO 201-01-123.
2. GENERAL TOLERANCE ± 0.20 UNLESS TOLERANCED.
3. INSULATOR MATERIAL: NYLON 46, UL94 V-0, COLOR REFER TO PAGE 18.
4. CONTACT MATERIAL: COPPER ALLOY, SELECTIVE GOLD OVER NICKEL, TIN PLATE ON TAILS.
5. BRACKETS: COPPER ALLOY, TIN PLATED.
6. OUTLINE OF CONNECTOR.
7. PACKING IN TAPE AND REEL, QUANTITY PER REEL 700.
8. PICK AND PLACE CAP TO BE REMOVED AFTER USE.
9. OPTIONAL SLOT: ONLY REQUIRED WHEN SOCKET HAS A LATCH, RADIUS ON ENDS OPTIONAL.

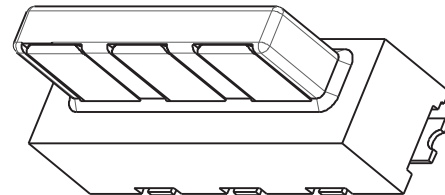
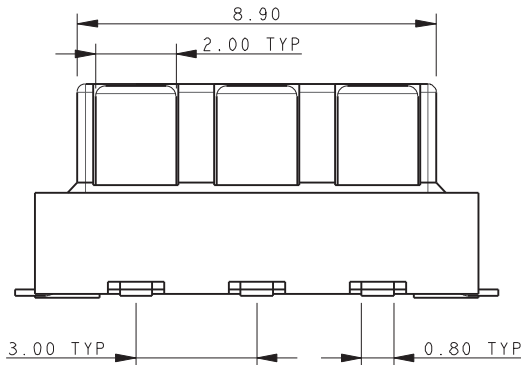
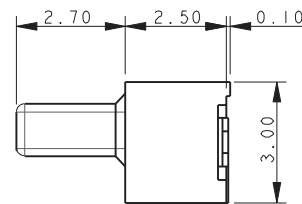
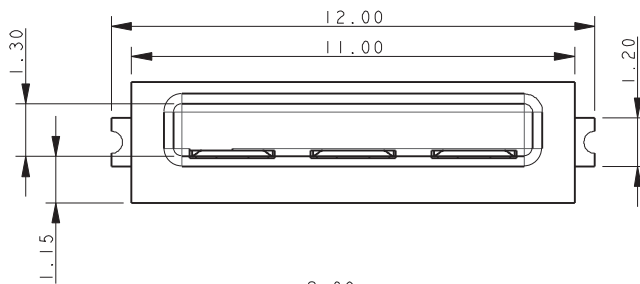

3 WAY PCB BOARD LAYOUT

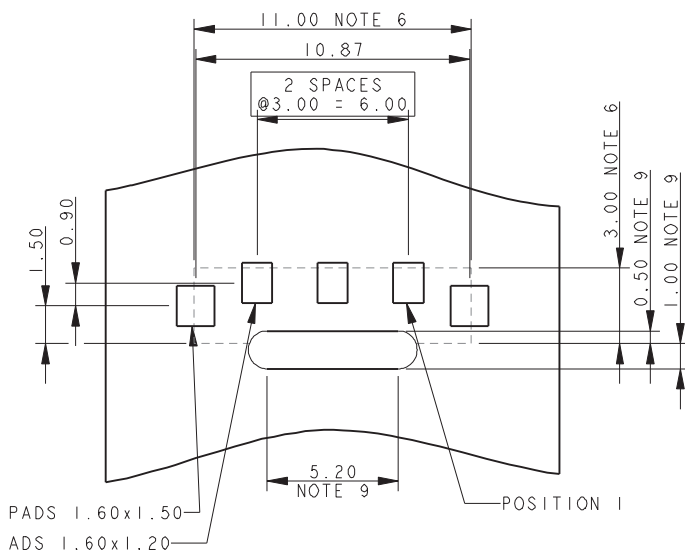

PACKING DETAILS

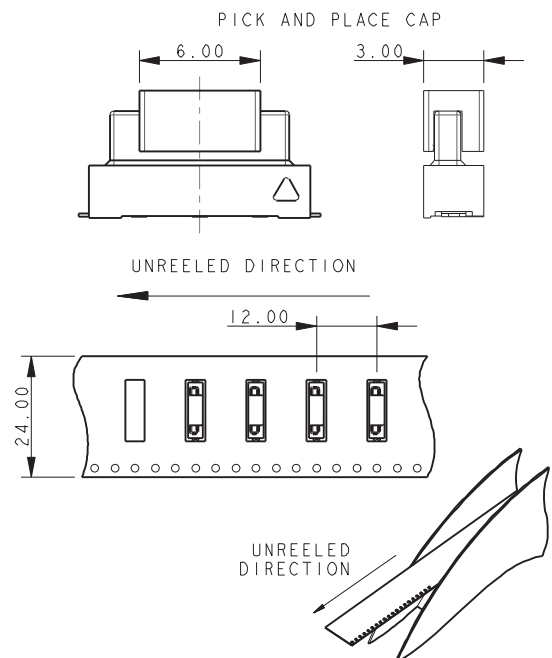

Vertical Plug: 13-9159-BTB

4 Position

PLUG – VERTICAL MOUNT 4 WAY 2 PART PCB STRIP CONNECTOR

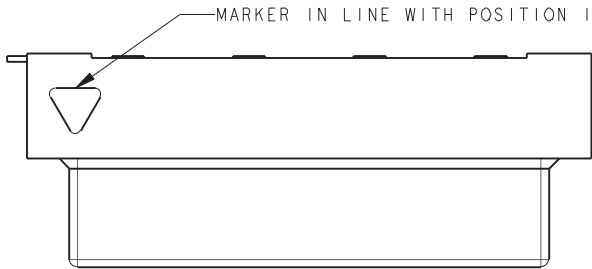

NOTES:

1. FOR FULL PRODUCT SPECIFICATION STANDARD CONNECTORS REFER TO ELCO SPEC 201-01-119, UL COMPONENTS REFER TO ELCO SPEC 201-01-119UL. FOR APPLICATION NOTES REFER TO 201-01-123.
2. GENERAL TOLERANCE ± 0.20 UNLESS TOLERANCED.
3. INSULATOR MATERIAL: NYLON 46, UL94 V-0, COLOR REFER TO PAGE 18.
4. CONTACT MATERIAL: COPPER ALLOY, SELECTIVE GOLD OVER NICKEL, TIN PLATE ON TAILS.
5. BRACKETS: COPPER ALLOY, TIN PLATED.
6. OUTLINE OF CONNECTOR.
7. PACKING IN TAPE AND REEL, QUANTITY PER REEL 700.
8. PICK AND PLACE CAP TO BE REMOVED AFTER USE.
9. OPTIONAL SLOT: ONLY REQUIRED WHEN SOCKET HAS A LATCH, RADIUS ON ENDS OPTIONAL.

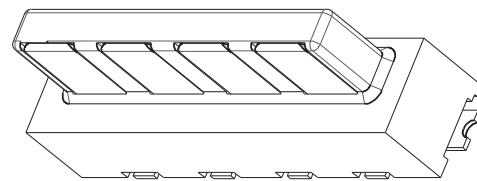
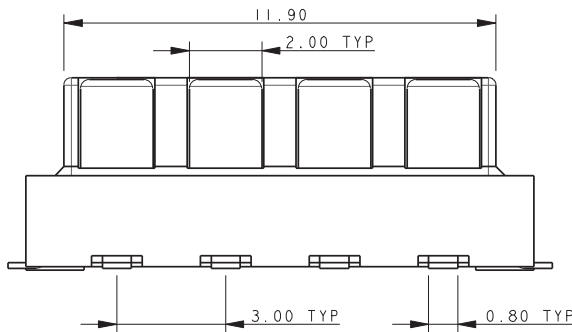
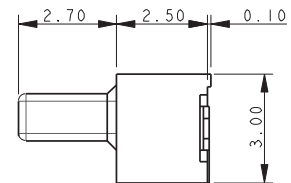
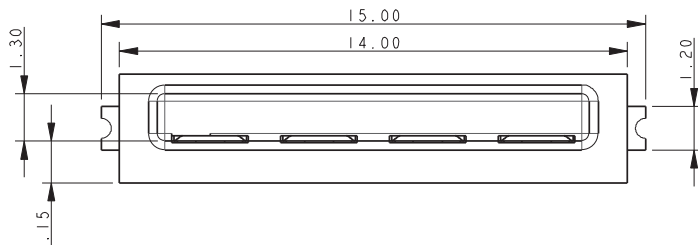

PACKING DETAILS

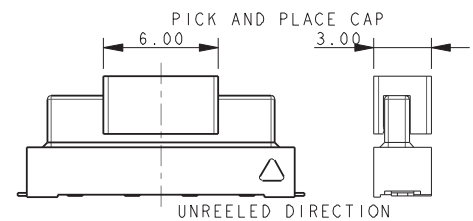

4 WAY PCB BOARD LAYOUT

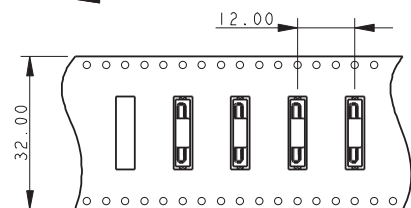
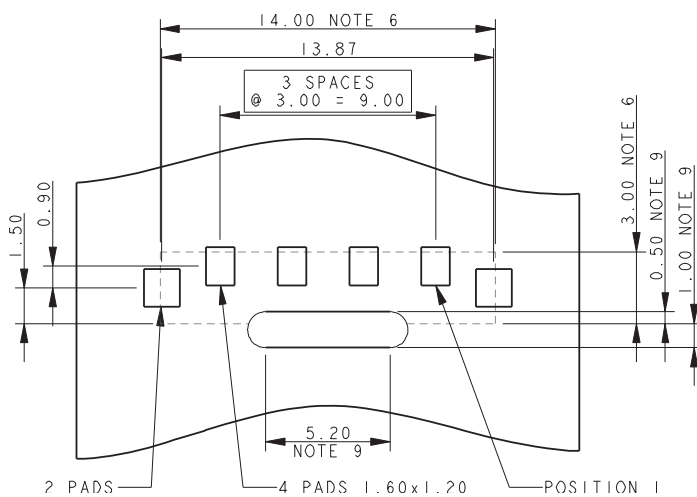

UNREEL DIRECTION

Vertical Plug: 13-9159-BTB

5 Position

PLUG – VERTICAL MOUNT 5 WAY 2 PART PCB STRIP CONNECTOR

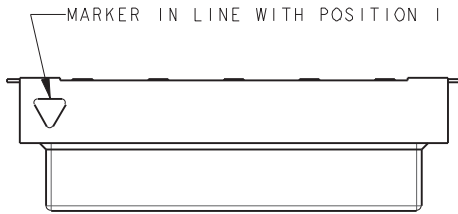

NOTES:

1. FOR FULL PRODUCT SPECIFICATION STANDARD CONNECTORS REFER TO ELCO SPEC 201-01-119, UL COMPONENTS REFER TO ELCO SPEC 201-01-119UL. FOR APPLICATION NOTES REFER TO 201-01-123.
2. GENERAL TOLERANCE ± 0.20 UNLESS TOLERANCED.
3. INSULATOR MATERIAL: NYLON 46, UL94 V-0, COLOR REFER TO PAGE 18.
4. CONTACT MATERIAL: COPPER ALLOY, SELECTIVE GOLD OVER NICKEL, TIN PLATE ON TAILS.
5. BRACKETS: COPPER ALLOY, TIN PLATED.
6. OUTLINE OF CONNECTOR.
7. PACKING IN TAPE AND REEL, QUANTITY PER REEL 700.
8. PICK AND PLACE CAP TO BE REMOVED AFTER USE.
9. OPTIONAL SLOT: ONLY REQUIRED WHEN SOCKET HAS A LATCH, RADIUS ON ENDS OPTIONAL.

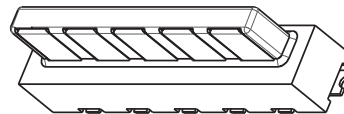
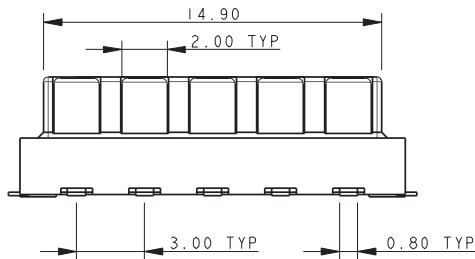
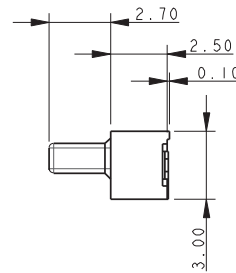
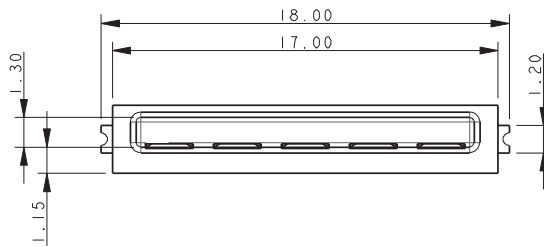

PACKING DETAILS

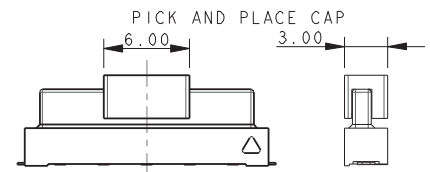

5 WAY PCB BOARD LAYOUT

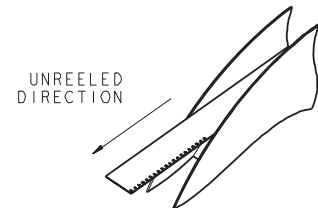
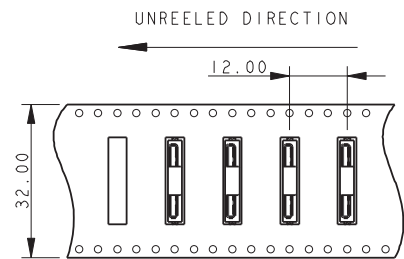
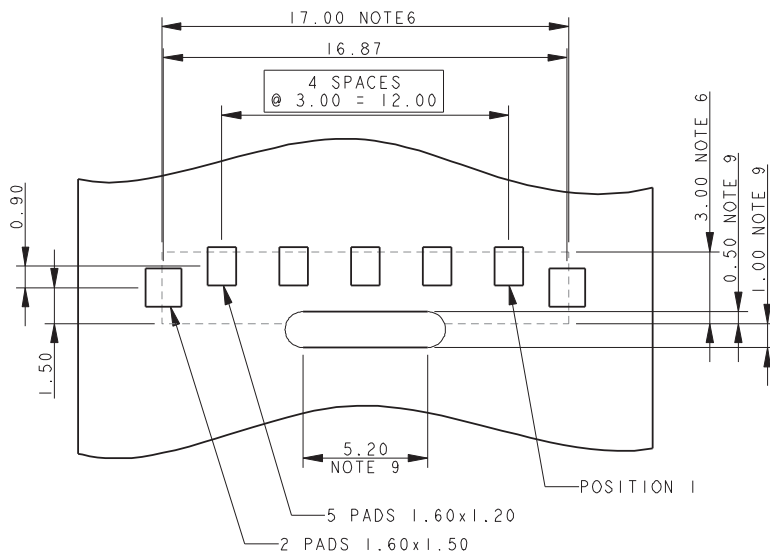

Vertical Plug: 13-9159 BTB

6 Position

PLUG – VERTICAL MOUNT 6 WAY 2 PART PCB STRIP CONNECTOR

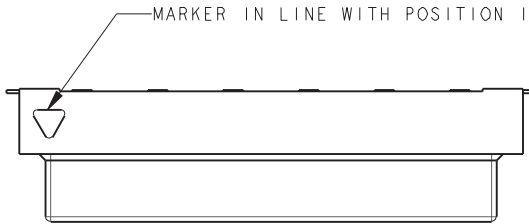

NOTES:

1. FOR FULL PRODUCT SPECIFICATION STANDARD CONNECTORS REFER TO ELCO SPEC 201-01-119, UL COMPONENTS REFER TO ELCO SPEC 201-01-119UL. FOR APPLICATION NOTES REFER TO 201-01-123.
2. GENERAL TOLERANCE ± 0.20 UNLESS TOLERANCED.
3. INSULATOR MATERIAL: NYLON 46, UL94 V-0, COLOR REFER TO PAGE 18.
4. CONTACT MATERIAL: COPPER ALLOY, SELECTIVE GOLD OVER NICKEL, TIN PLATE ON TAILS.
5. BRACKETS: COPPER ALLOY, TIN PLATED.
6. OUTLINE OF CONNECTOR.
7. PACKING IN TAPE AND REEL, QUANTITY PER REEL 700.
8. PICK AND PLACE CAP TO BE REMOVED AFTER USE.
9. OPTIONAL SLOT: ONLY REQUIRED WHEN SOCKET HAS A LATCH, RADIUS ON ENDS OPTIONAL.

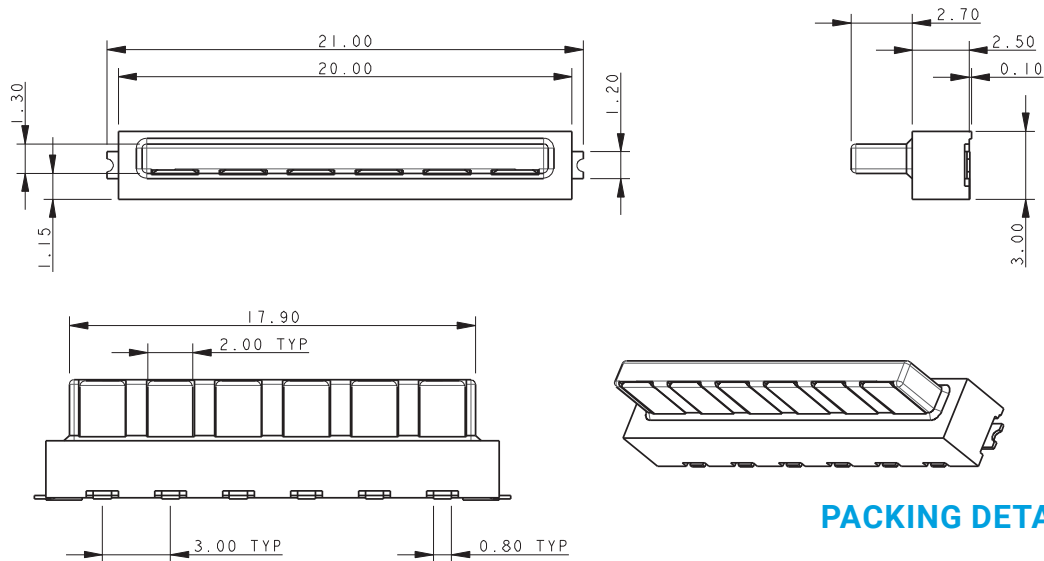

PACKING DETAILS

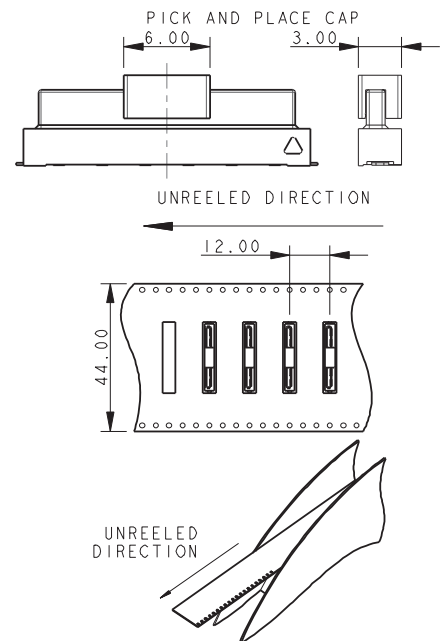

6 WAY PCB BOARD LAYOUT

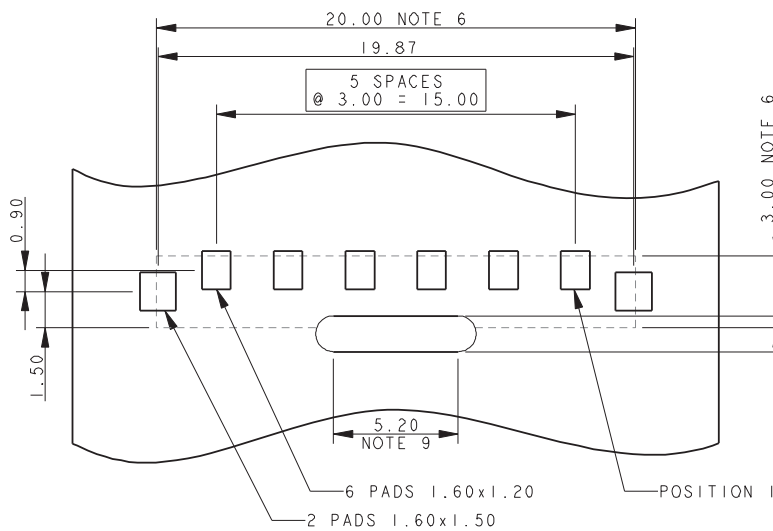

IDC Plug: 14-9159-WTB

General Description



KYOCERA AVX developed the 9159 Series of SMT connectors for co-planar PCB mating for the challenging Solid State Lighting (SSL) market. These connectors needed to be small, low in height, carry up to 5 Amps/contact and then function up to 125C for extended periods. This application has been very unique to the SSL market where PCB's are stacked end-to-end to create linear strip lighting in everything from office to transportation applications where products are exposed to harsh mechanical and environmental environments.

The IDC cable plug connector allows for 22-24AWG discrete or cabled wires to be easily and reliability terminated into a 9159 standard interface socket connector. This will allow power and signals to be connectors onto a PCB socket connector while providing positive latching. The wire assembly support block allows for 2 through 6 wires to be terminated all in one step with any standard bench top press. IDC covers provide both through (daisy chain applications) and wire stop termination options.

APPLICATIONS

- Provides Wire-to-Board capabilities to standard 9159 2-Piece connector system
- In conjunction with the IDC socket WTB connector (24-9159), these connectors provide maximum flexibility to bring power and signal wires onto or off of any board level 9159 connector
- Reference application notes 201-01-123
- Reference Product Specification 201-01-119

FEATURES AND BENEFITS

- Mates with standard 9159 horizontal socket, keeping same BTB connector system
- Economical and reliable IDC wire termination
- Gold plated BeCu contact system for high reliability in harsh environments
- Integrally molded latch offers positive latching after mating

ELECTRICAL

- Current Rating: 5 Amps / Contact
- Voltage Rating: 125 VAC

ENVIRONMENTAL

- Operating Temperature: -40°C to +125°C

MECHANICAL

- Insulator Material: Nylon: UL94V0
- Contact Material: Phosphor Bronze
- Plating: Gold / Tin over Nickel
- Durability: 10 Cycles

HOW TO ORDER

14	9159	00X	1	X	2	9	X	6																																																			
Prefix Right Angle Wired Plug IDC	Series	Number of Ways	2 Part PCB Strip Connector 2 Part Wired IDC Strip Connector	Wire Gauge 2 = 22AWG 3 = 24AWG	Wire Insulation Diameter ø1.10mm to ø1.60mm	Color Options 9 = UL	Cap Options	Plating Option																																																			
		<table border="1"> <thead> <tr> <th>Code</th> <th>No of Ways</th> <th>Details</th> </tr> </thead> <tbody> <tr> <td colspan="3">THROUGH WIRE CAP</td> </tr> <tr> <td>002</td> <td>2</td> <td>Page 25</td> </tr> <tr> <td>003</td> <td>3</td> <td>Page 26</td> </tr> <tr> <td>004</td> <td>4</td> <td>Page 27</td> </tr> <tr> <td>005</td> <td>5</td> <td>Page 28</td> </tr> <tr> <td>006</td> <td>6</td> <td>Page 29</td> </tr> <tr> <td colspan="3">WIRE STOP CAP</td> </tr> <tr> <td>002</td> <td>2</td> <td>Page 30</td> </tr> <tr> <td>003</td> <td>3</td> <td>Page 31</td> </tr> <tr> <td>004</td> <td>4</td> <td>Page 32</td> </tr> <tr> <td>005</td> <td>5</td> <td>Page 33</td> </tr> <tr> <td>006</td> <td>6</td> <td>Page 34</td> </tr> </tbody> </table>	Code	No of Ways	Details	THROUGH WIRE CAP			002	2	Page 25	003	3	Page 26	004	4	Page 27	005	5	Page 28	006	6	Page 29	WIRE STOP CAP			002	2	Page 30	003	3	Page 31	004	4	Page 32	005	5	Page 33	006	6	Page 34				<table border="1"> <thead> <tr> <th>Code</th> <th>Cap Option</th> <th>Description</th> </tr> </thead> <tbody> <tr> <td>0</td> <td>Through Wire</td> <td>Allows wires to be terminated at any point</td> </tr> <tr> <td>9</td> <td>Wire Stop</td> <td>Terminates end of wire. End protected with Stop Face</td> </tr> </tbody> </table>	Code	Cap Option	Description	0	Through Wire	Allows wires to be terminated at any point	9	Wire Stop	Terminates end of wire. End protected with Stop Face	<table border="1"> <thead> <tr> <th>Code</th> <th>Contact</th> </tr> </thead> <tbody> <tr> <td>6</td> <td>Gold on Contact Tin on IDC</td> </tr> </tbody> </table>	Code	Contact	6	Gold on Contact Tin on IDC
Code	No of Ways	Details																																																									
THROUGH WIRE CAP																																																											
002	2	Page 25																																																									
003	3	Page 26																																																									
004	4	Page 27																																																									
005	5	Page 28																																																									
006	6	Page 29																																																									
WIRE STOP CAP																																																											
002	2	Page 30																																																									
003	3	Page 31																																																									
004	4	Page 32																																																									
005	5	Page 33																																																									
006	6	Page 34																																																									
Code	Cap Option	Description																																																									
0	Through Wire	Allows wires to be terminated at any point																																																									
9	Wire Stop	Terminates end of wire. End protected with Stop Face																																																									
Code	Contact																																																										
6	Gold on Contact Tin on IDC																																																										



Certification: UL File #E90723

IDC Plug: 14-9159-WTB

2 Position Through Wire Cap

PLUG-WIRED – 2 WAY THROUGH WIRE CAP

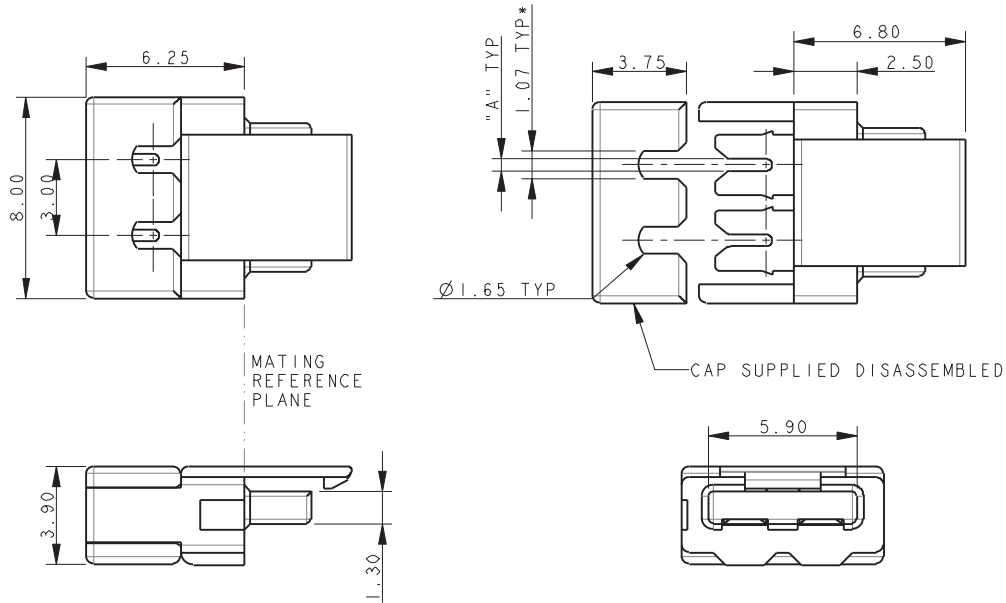

NOTES:

1. FOR MORE INFORMATION REFER TO PRODUCT SPEC 201-01-119. FOR WIRE ASSEMBLY REFER TO APPLICATION NOTES 201-01-123.
2. THROUGH WIRE CAP, FOR TERMINATION OF WIRE IN ANY POSITION.
3. CAP ACTS AS WIRE ASSEMBLY TOOL. WIRE PREFIT TO CAP, NARROW SLOT TO GRIP WIRE, PERMANENT ASSEMBLY.
4. GENERAL TOLERANCE ± 0.20 UNLESS SPECIFIED.
5. INSULATOR MATERIAL: NYLON 46, GLASS FILLED, UL94 V-0. COLOR REFER TO PAGE 24.
6. CONTACT MATERIAL: COPPER ALLOY, PLATING NICKEL BASE ALL OVER, GOLD ON CONTACT, TIN ON IDC.
7. PACKING IN TAPE AND REEL. QTY PER REEL 700, POCKET CONTAINS 1 CONNECTOR AND 1 CAP.
8. WIRE GAUGE OPTIONS, SEE TABLE.
9. ASSEMBLY AIDS, REFER TO PAGE 35.

Wire Gauge	Code (Page 24)	Dimension A	Wire Insulation Diameter
22AWG (Stranded Wire)	122	0.47	1.10 to 1.60
24AWG (Stranded Wire)	132	0.37	1.10 to 1.60

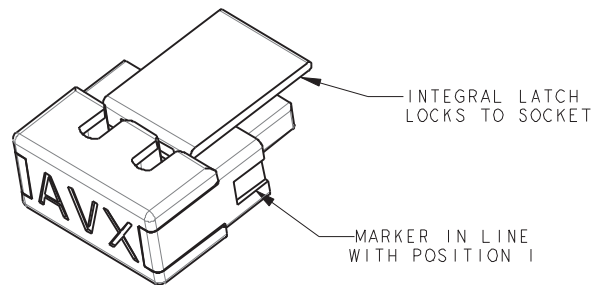
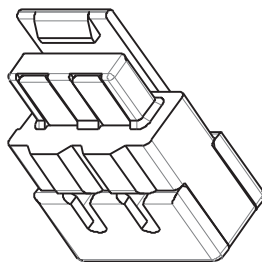

PACKING DETAILS CAP AND CONNECTOR SUPPLIED TOGETHER (2 PARTS)

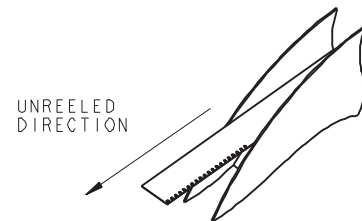
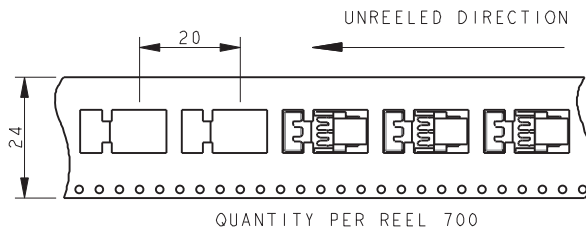

IDC Plug: 14-9159-WTB

3 Position Through Wire Cap

PLUG-WIRED – 3 WAY THROUGH WIRE CAP

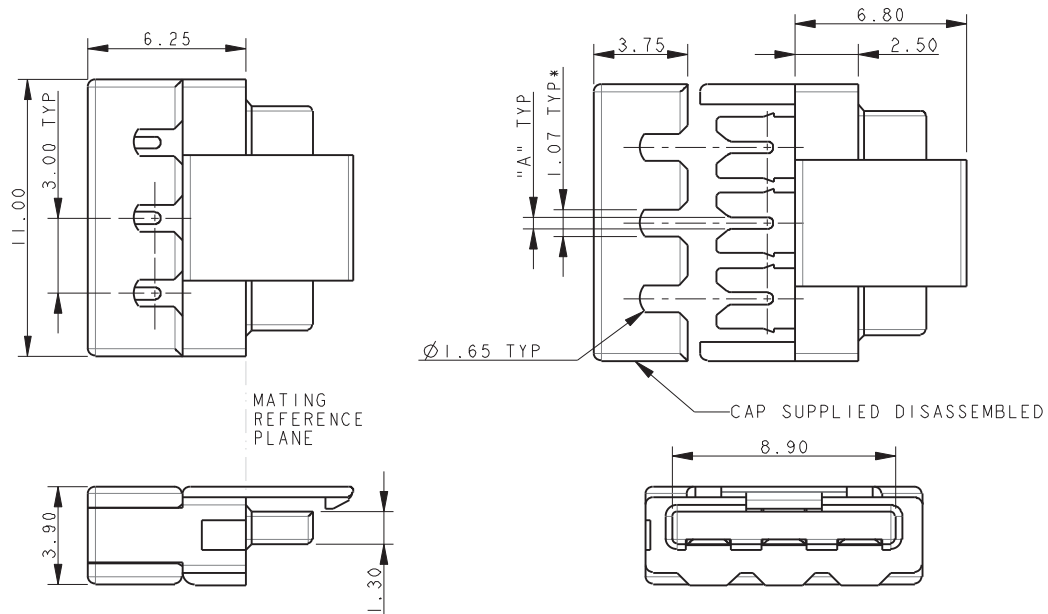

NOTES:

1. FOR MORE INFORMATION REFER TO PRODUCT SPEC 201-01-119. FOR WIRE ASSEMBLY REFER TO APPLICATION NOTES 201-01-123.
2. THROUGH WIRE CAP, FOR TERMINATION OF WIRE IN ANY POSITION.
3. CAP ACTS AS WIRE ASSEMBLY TOOL. WIRE PREFIT TO CAP, NARROW SLOT TO GRIP WIRE, PERMANENT ASSEMBLY.
4. GENERAL TOLERANCE ± 0.20 UNLESS SPECIFIED.
5. INSULATOR MATERIAL: NYLON 46, GLASS FILLED, UL94 V-0. COLOR REFER TO PAGE 24.
6. CONTACT MATERIAL: COPPER ALLOY, PLATING NICKEL BASE ALL OVER, GOLD ON CONTACT, TIN ON IDC.
7. PACKING IN TAPE AND REEL. QTY PER REEL 700, POCKET CONTAINS 1 CONNECTOR AND 1 CAP.
8. WIRE GAUGE OPTIONS, SEE TABLE.
9. ASSEMBLY AIDS, REFER TO PAGE 35.

Wire Gauge	Code (Page 24)	Dimension A	Wire Insulation Diameter
22AWG (Stranded Wire)	122	0.47	1.10 to 1.60
24AWG (Stranded Wire)	132	0.37	1.10 to 1.60

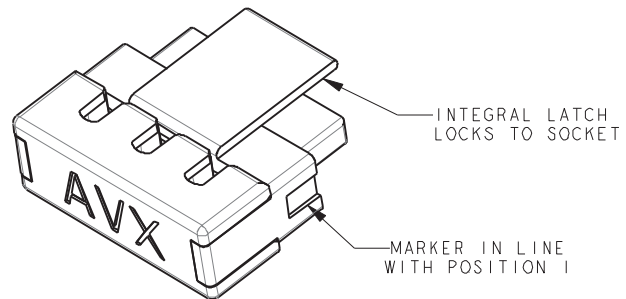
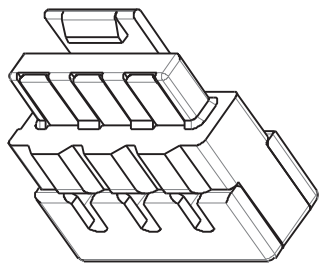

PACKING DETAILS CAP AND CONNECTOR SUPPLIED TOGETHER (2 PARTS)

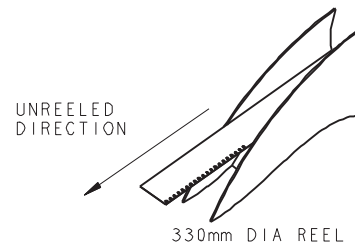
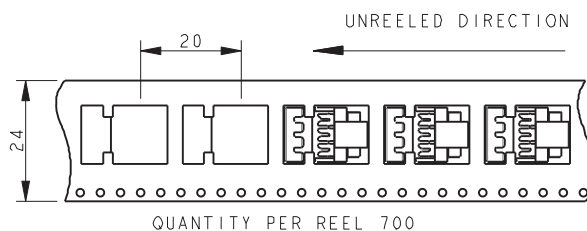

IDC Plug: 14-9159-WTB

4 Position Through Wire Cap

PLUG-WIRED – 4 WAY THROUGH WIRE CAP

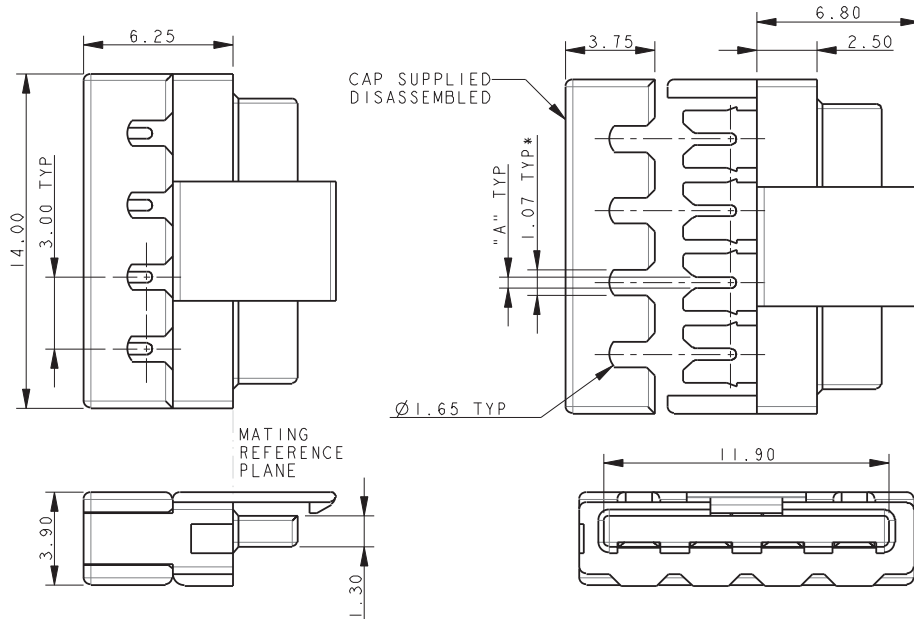

NOTES:

1. FOR MORE INFORMATION REFER TO PRODUCT SPEC 201-01-119. FOR WIRE ASSEMBLY REFER TO APPLICATION NOTES 201-01-123.
2. THROUGH WIRE CAP, FOR TERMINATION OF WIRE IN ANY POSITION.
3. CAP ACTS AS WIRE ASSEMBLY TOOL. WIRE PREFIT TO CAP, NARROW SLOT TO GRIP WIRE, PERMANENT ASSEMBLY.
4. GENERAL TOLERANCE ± 0.20 UNLESS SPECIFIED.
5. INSULATOR MATERIAL: NYLON 46, GLASS FILLED, UL94 V-0. COLOR REFER TO PAGE 24.
6. CONTACT MATERIAL: COPPER ALLOY, PLATING NICKEL BASE ALL OVER, GOLD ON CONTACT, TIN ON IDC.
7. PACKING IN TAPE AND REEL. QTY PER REEL 700, POCKET CONTAINS 1 CONNECTOR AND 1 CAP.
8. WIRE GAUGE OPTIONS, SEE TABLE.
9. ASSEMBLY AIDS, REFER TO PAGE 35.

Wire Gauge	Code (Page 24)	Dimension A	Wire Insulation Diameter
22AWG (Stranded Wire)	122	0.47	1.10 to 1.60
24AWG (Stranded Wire)	132	0.37	1.10 to 1.60

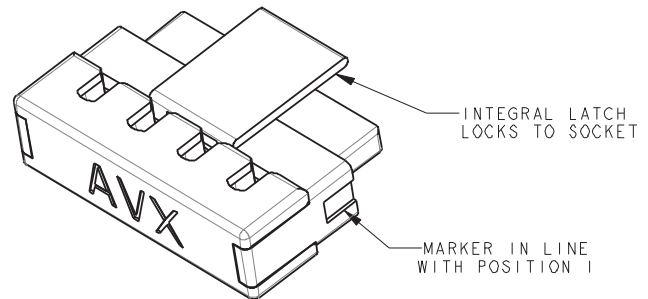
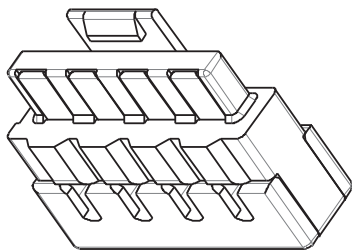

PACKING DETAILS CAP AND CONNECTOR SUPPLIED TOGETHER (2 PARTS)

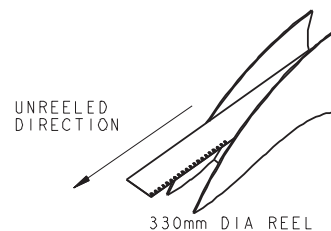
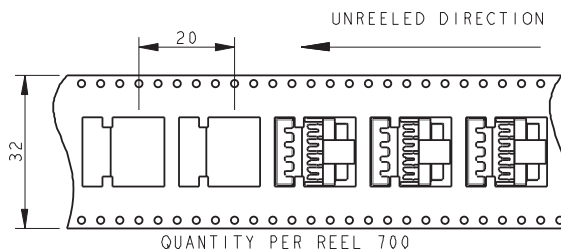

IDC Plug: 14-9159-WTB

5 Position Through Wire Cap

PLUG-WIRED – 5 WAY THROUGH WIRE CAP

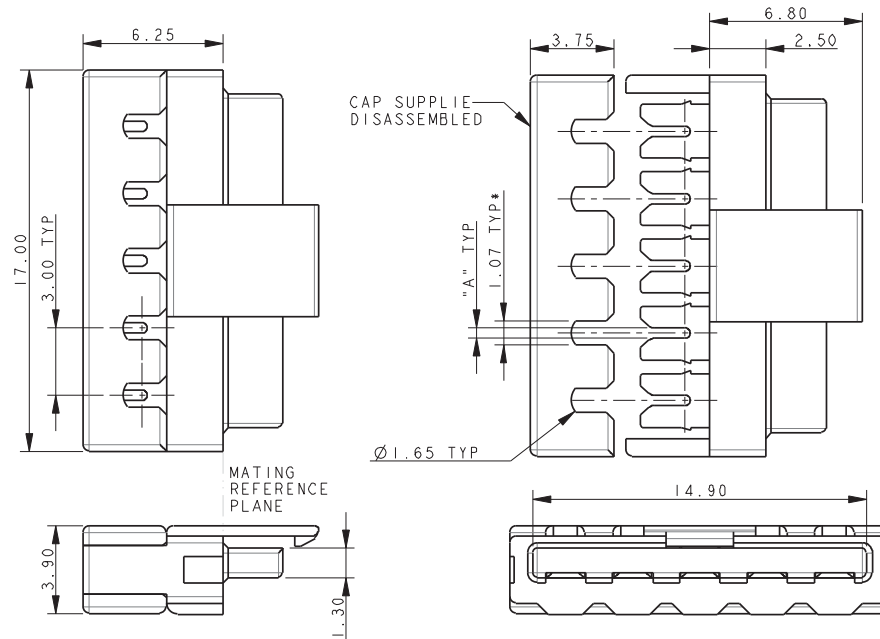

NOTES:

1. FOR MORE INFORMATION REFER TO PRODUCT SPEC 201-01-119. FOR WIRE ASSEMBLY REFER TO APPLICATION NOTES 201-01-123.
2. THROUGH WIRE CAP, FOR TERMINATION OF WIRE IN ANY POSITION.
3. CAP ACTS AS WIRE ASSEMBLY TOOL. WIRE PREFIT TO CAP, NARROW SLOT TO GRIP WIRE, PERMANENT ASSEMBLY.
4. GENERAL TOLERANCE ± 0.20 UNLESS SPECIFIED.
5. INSULATOR MATERIAL: NYLON 46, GLASS FILLED, UL94 V-0. COLOR REFER TO PAGE 24.
6. CONTACT MATERIAL: COPPER ALLOY, PLATING NICKEL BASE ALL OVER, GOLD ON CONTACT, TIN ON IDC.
7. PACKING IN TAPE AND REEL. QTY PER REEL 700, POCKET CONTAINS 1 CONNECTOR AND 1 CAP.
8. WIRE GAUGE OPTIONS, SEE TABLE.
9. ASSEMBLY AIDS, REFER TO PAGE 35.

Wire Gauge	Code (Page 24)	Dimension A	Wire Insulation Diameter
22AWG (Stranded Wire)	122	0.47	1.10 to 1.60
24AWG (Stranded Wire)	132	0.37	1.10 to 1.60

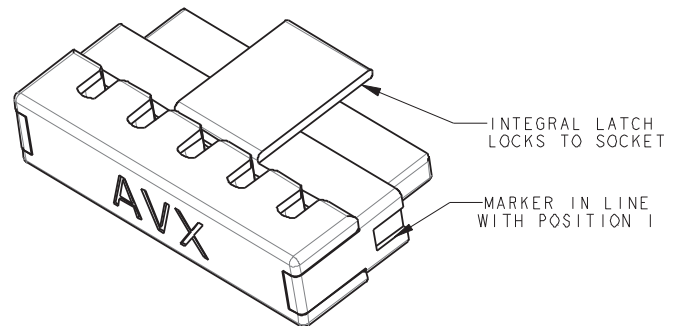
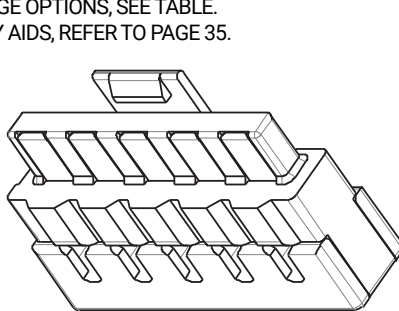

PACKING DETAILS CAP AND CONNECTOR SUPPLIED TOGETHER (2 PARTS)

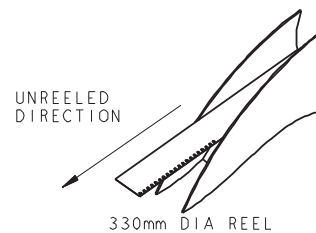
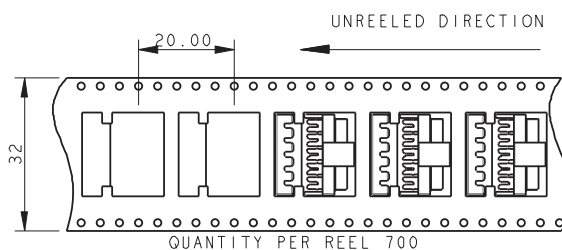

IDC Plug: 14-9159-WTB

6 Position Through Wire Cap

PLUG-WIRED – 6 WAY THROUGH WIRE CAP

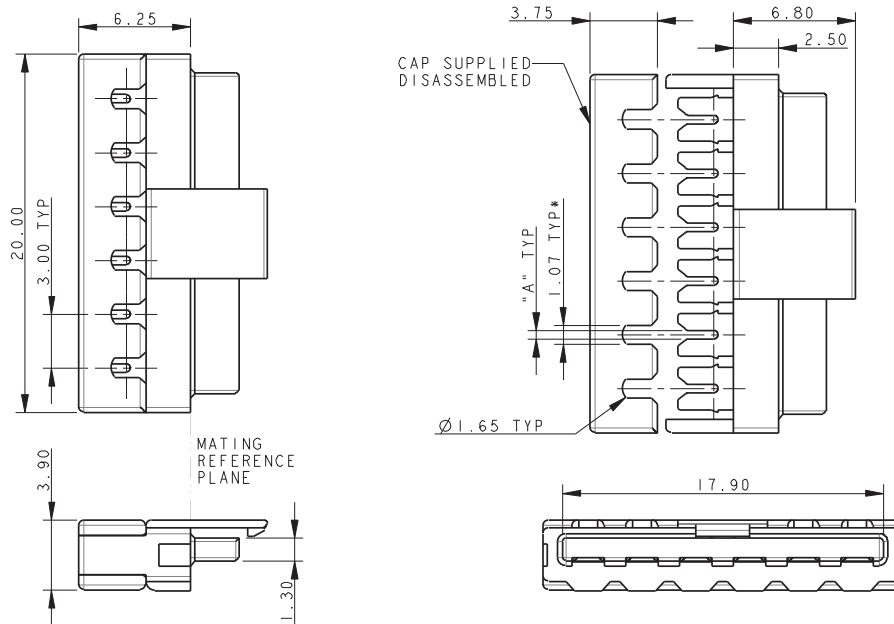

NOTES:

1. FOR MORE INFORMATION REFER TO PRODUCT SPEC 201-01-119. FOR WIRE ASSEMBLY REFER TO APPLICATION NOTES 201-01-123.
2. THROUGH WIRE CAP, FOR TERMINATION OF WIRE IN ANY POSITION.
3. CAP ACTS AS WIRE ASSEMBLY TOOL. WIRE PREFIT TO CAP, NARROW SLOT TO GRIP WIRE, PERMANENT ASSEMBLY.
4. GENERAL TOLERANCE ± 0.20 UNLESS SPECIFIED.
5. INSULATOR MATERIAL: NYLON 46, GLASS FILLED, UL94 V-0. COLOR REFER TO PAGE 24.
6. CONTACT MATERIAL: COPPER ALLOY, PLATING NICKEL BASE ALL OVER, GOLD ON CONTACT, TIN ON IDC.
7. PACKING IN TAPE AND REEL. QTY PER REEL 700, POCKET CONTAINS 1 CONNECTOR AND 1 CAP.
8. WIRE GAUGE OPTIONS, SEE TABLE.
9. ASSEMBLY AIDS, REFER TO PAGE 35.

Wire Gauge	Code (Page 24)	Dimension A	Wire Insulation Diameter
22AWG (Stranded Wire)	122	0.47	1.10 to 1.60
24AWG (Stranded Wire)	132	0.37	1.10 to 1.60

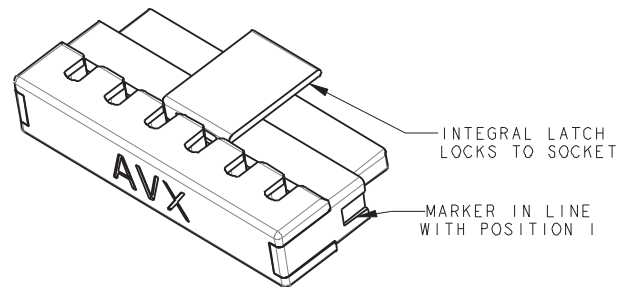
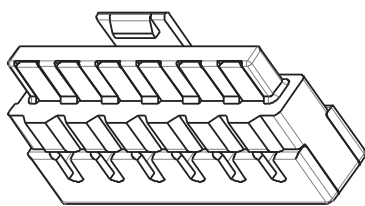

PACKING DETAILS CAP AND CONNECTOR SUPPLIED TOGETHER (2 PARTS)

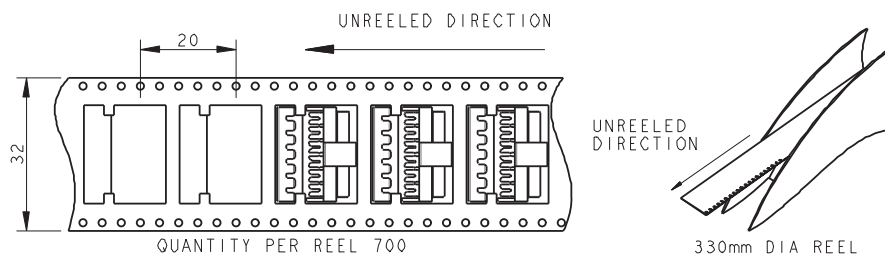

IDC Plug: 14-9159-WTB

2 Position Wire Stop Cap

PLUG-WIRED – 2 WAY WIRE STOP CAP

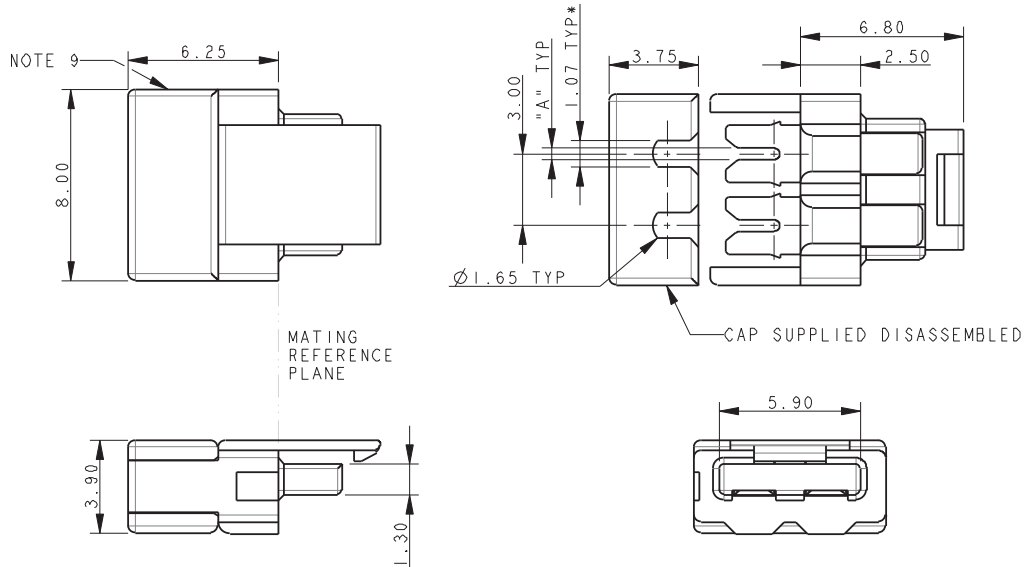

NOTES:

1. FOR MORE INFORMATION REFER TO PRODUCT SPEC 201-01-119. FOR WIRE ASSEMBLY REFER TO APPLICATION NOTES 201-01-123.
2. WIRE STOP CAP, WITH STOP FACE ON ONE SIDE TO PROTECT END OF WIRE.
3. CAP ACTS AS WIRE ASSEMBLY TOOL. WIRE PREFIT TO CAP, NARROW SLOT TO GRIP WIRE, PERMANENT ASSEMBLY.
4. GENERAL TOLERANCE ± 0.20 UNLESS SPECIFIED.
5. INSULATOR MATERIAL: NYLON 46, GLASS FILLED, UL94 V-0. COLOR REFER TO PAGE 24.
6. CONTACT MATERIAL: COPPER ALLOY, PLATING NICKEL BASE ALL OVER, GOLD ON CONTACT, TIN ON IDC.
7. PACKING IN TAPE AND REEL. QTY PER REEL 700, POCKET CONTAINS 1 CONNECTOR AND 1 CAP.
8. WIRE GAUGE OPTIONS, SEE TABLE.
9. SHOWN WITH WIRE ENTRY FROM UNDERSIDE, CAP CAN BE ASSEMBLED FOR EITHER TOP OR UNDERSIDE WIRE ENTRY.
10. ASSEMBLY AIDS, REFER TO PAGE 35.

Wire Gauge	Code (Page 24)	Dimension A	Wire Insulation Diameter
22AWG (Stranded Wire)	122	0.47	1.10 to 1.60
24AWG (Stranded Wire)	132	0.37	1.10 to 1.60

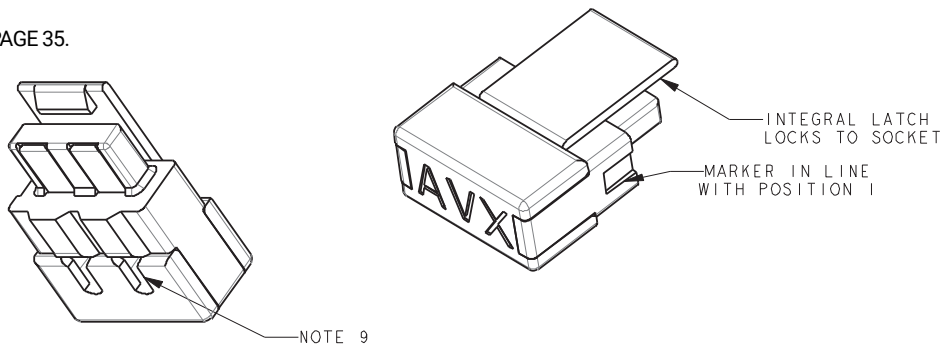

PACKING DETAILS CAP AND CONNECTOR SUPPLIED TOGETHER (2 PARTS)

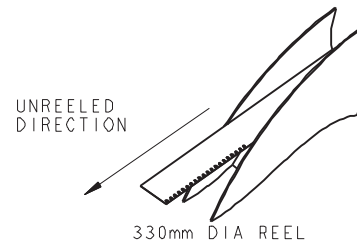
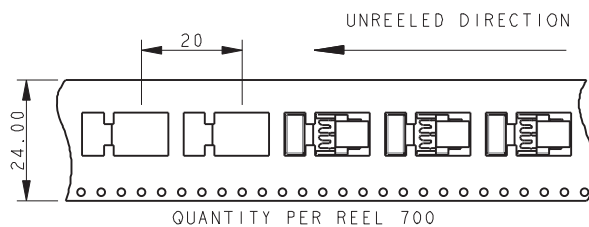

IDC Plug: 14-9159-WTB

3 Position Wire Stop Cap

PLUG-WIRED – 3 WAY WIRE STOP CAP

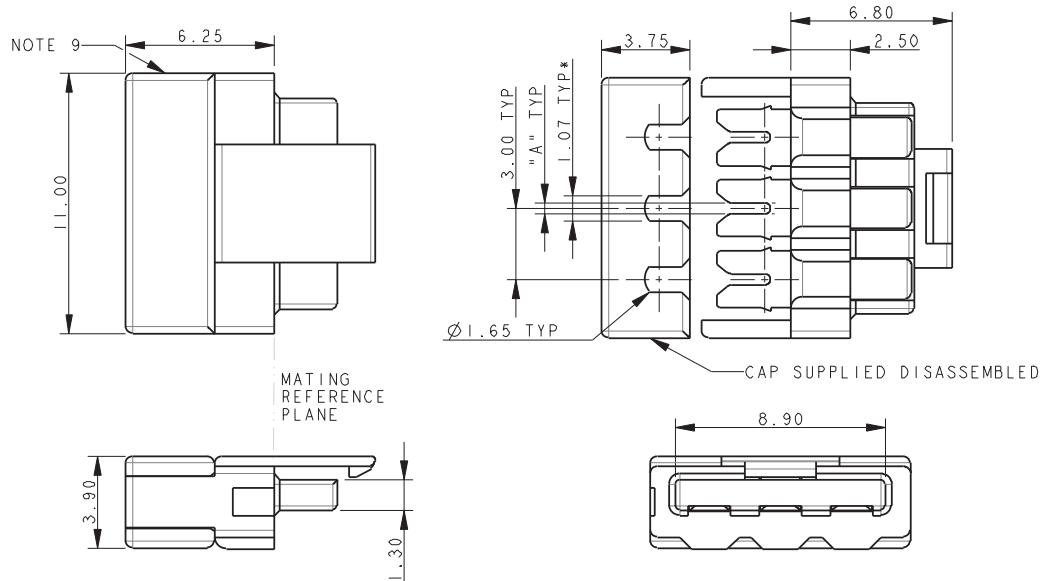

NOTES:

1. FOR MORE INFORMATION REFER TO PRODUCT SPEC 201-01-119. FOR WIRE ASSEMBLY REFER TO APPLICATION NOTES 201-01-123.
2. WIRE STOP CAP, WITH STOP FACE ON ONE SIDE TO PROTECT END OF WIRE.
3. CAP ACTS AS WIRE ASSEMBLY TOOL. WIRE PREFIT TO CAP, NARROW SLOT TO GRIP WIRE, PERMANENT ASSEMBLY.
4. GENERAL TOLERANCE ± 0.20 UNLESS SPECIFIED.
5. INSULATOR MATERIAL: NYLON 46, GLASS FILLED, UL94 V-0. COLOR REFER TO PAGE 24.
6. CONTACT MATERIAL: COPPER ALLOY, PLATING NICKEL BASE ALL OVER, GOLD ON CONTACT, TIN ON IDC.
7. PACKING IN TAPE AND REEL. QTY PER REEL 700, POCKET CONTAINS 1 CONNECTOR AND 1 CAP.
8. WIRE GAUGE OPTIONS, SEE TABLE.
9. SHOWN WITH WIRE ENTRY FROM UNDERSIDE, CAP CAN BE ASSEMBLED FOR EITHER TOP OR UNDERSIDE WIRE ENTRY.
10. ASSEMBLY AIDS, REFER TO PAGE 35.

Wire Gauge	Code (Page 24)	Dimension A	Wire Insulation Diameter
22AWG (Stranded Wire)	122	0.47	1.10 to 1.60
24AWG (Stranded Wire)	132	0.37	1.10 to 1.60

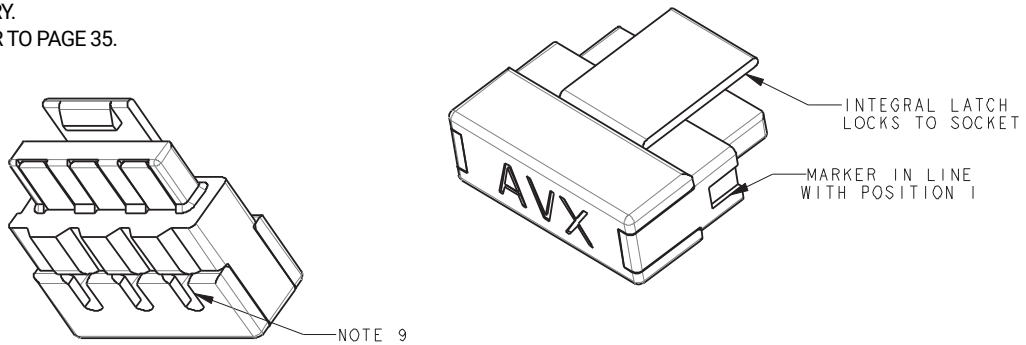

PACKING DETAILS CAP AND CONNECTOR SUPPLIED TOGETHER (2 PARTS)

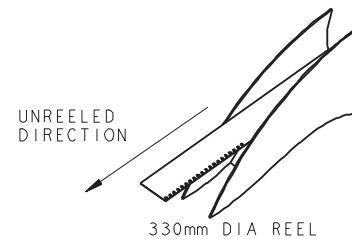
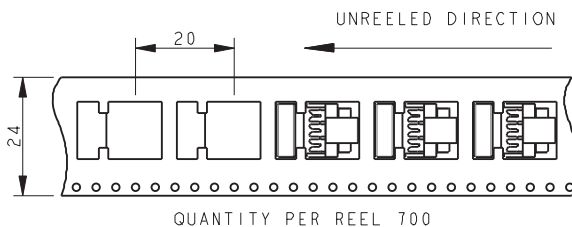

IDC Plug: 14-9159-WTB

4 Position Wire Stop Cap

PLUG-WIRED – 4 WAY WIRE STOP CAP

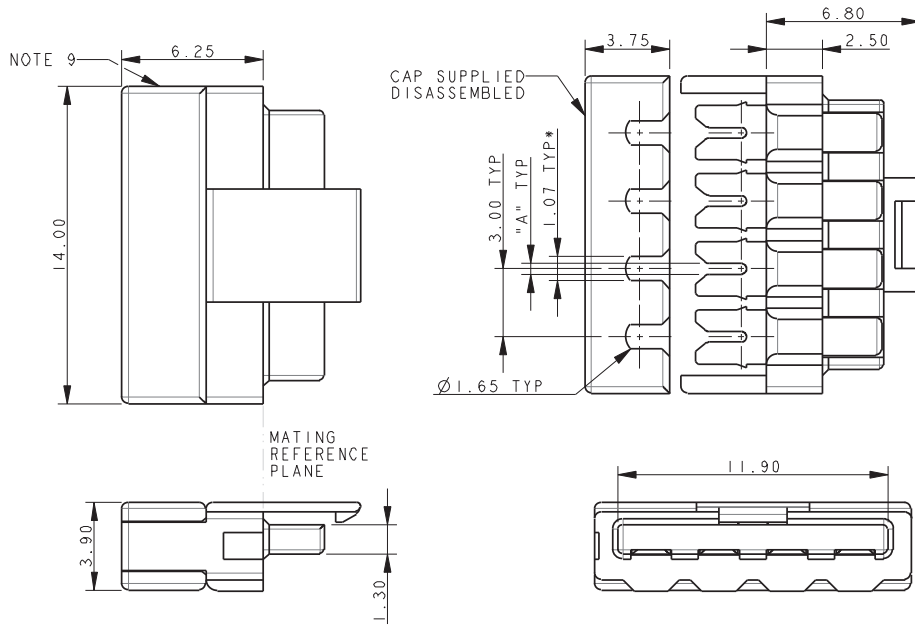

NOTES:

- FOR MORE INFORMATION REFER TO PRODUCT SPEC 201-01-119.
FOR WIRE ASSEMBLY REFER TO APPLICATION NOTES 201-01-123.
- WIRE STOP CAP, WITH STOP FACE ON ONE SIDE TO PROTECT END OF WIRE.
- CAP ACTS AS WIRE ASSEMBLY TOOL. WIRE PREFIT TO CAP, NARROW SLOT TO GRIP WIRE, PERMANENT ASSEMBLY.
- GENERAL TOLERANCE ± 0.20 UNLESS SPECIFIED.
- INSULATOR MATERIAL: NYLON 46, GLASS FILLED, UL94 V-0. COLOR REFER TO PAGE 24.
- CONTACT MATERIAL: COPPER ALLOY, PLATING NICKEL BASE ALL OVER, GOLD ON CONTACT, TIN ON IDC.
- PACKING IN TAPE AND REEL. QTY PER REEL 700, POCKET CONTAINS 1 CONNECTOR AND 1 CAP.
- WIRE GAUGE OPTIONS, SEE TABLE.
- SHOWN WITH WIRE ENTRY FROM UNDERSIDE, CAP CAN BE ASSEMBLED FOR EITHER TOP OR UNDERSIDE WIRE ENTRY.
- ASSEMBLY AIDS, REFER TO PAGE 35.

Wire Gauge	Code (Page 24)	Dimension A	Wire Insulation Diameter
22AWG (Stranded Wire)	122	0.47	1.10 to 1.60
24AWG (Stranded Wire)	132	0.37	1.10 to 1.60

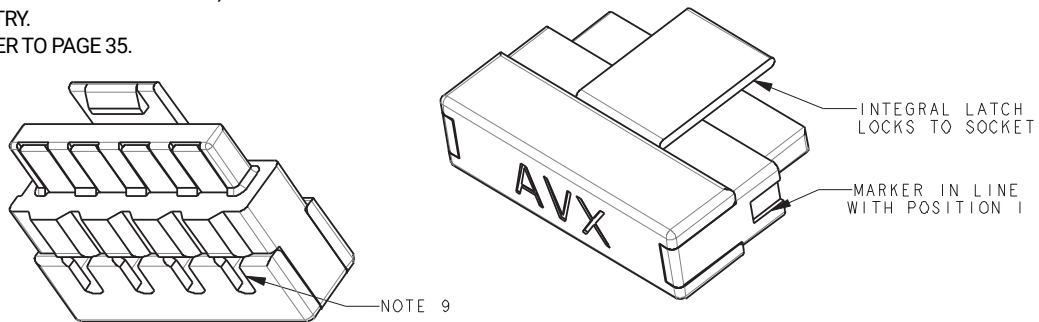

PACKING DETAILS CAP AND CONNECTOR SUPPLIED TOGETHER (2 PARTS)

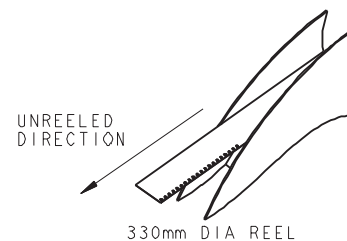
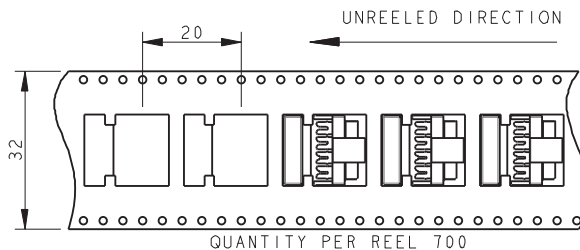

IDC Plug: 14-9159-WTB

5 Position Wire Stop Cap

PLUG-WIRED – 5 WAY WIRE STOP CAP

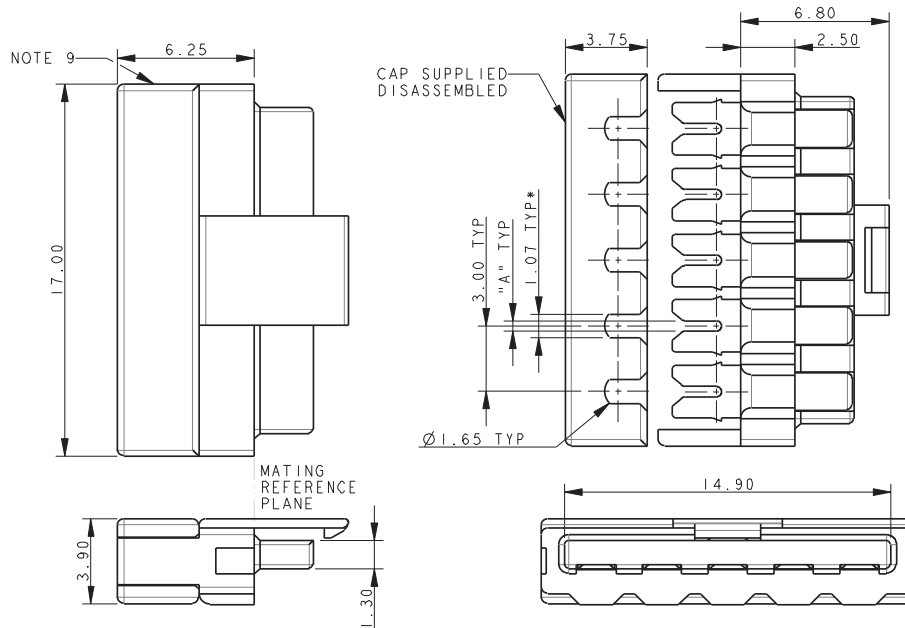

NOTES:

1. FOR MORE INFORMATION REFER TO PRODUCT SPEC 201-01-119. FOR WIRE ASSEMBLY REFER TO APPLICATION NOTES 201-01-123.
2. WIRE STOP CAP, WITH STOP FACE ON ONE SIDE TO PROTECT END OF WIRE.
3. CAP ACTS AS WIRE ASSEMBLY TOOL. WIRE PREFIT TO CAP, NARROW SLOT TO GRIP WIRE, PERMANENT ASSEMBLY.
4. GENERAL TOLERANCE ± 0.20 UNLESS SPECIFIED.
5. INSULATOR MATERIAL: NYLON 46, GLASS FILLED, UL94 V-0. COLOR REFER TO PAGE 24.
6. CONTACT MATERIAL: COPPER ALLOY, PLATING NICKEL BASE ALL OVER, GOLD ON CONTACT, TIN ON IDC.
7. PACKING IN TAPE AND REEL. QTY PER REEL 700, POCKET CONTAINS 1 CONNECTOR AND 1 CAP.
8. WIRE GAUGE OPTIONS, SEE TABLE.
9. SHOWN WITH WIRE ENTRY FROM UNDERSIDE, CAP CAN BE ASSEMBLED FOR EITHER TOP OR UNDERSIDE WIRE ENTRY.
10. ASSEMBLY AIDS, REFER TO PAGE 35.

Wire Gauge	Code (Page 24)	Dimension A	Wire Insulation Diameter
22AWG (Stranded Wire)	122	0.47	1.10 to 1.60
24AWG (Stranded Wire)	132	0.37	1.10 to 1.60

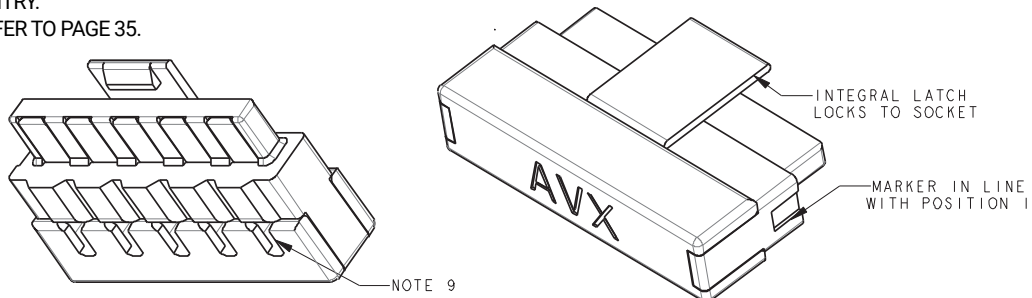

PACKING DETAILS CAP AND CONNECTOR SUPPLIED TOGETHER (2 PARTS)

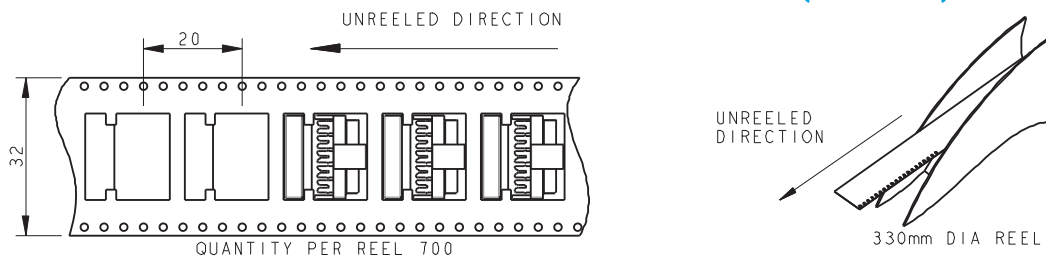

IDC Plug: 14-9159-WTB

6 Position Wire Stop Cap

PLUG-WIRED – 6 WAY WIRE STOP CAP

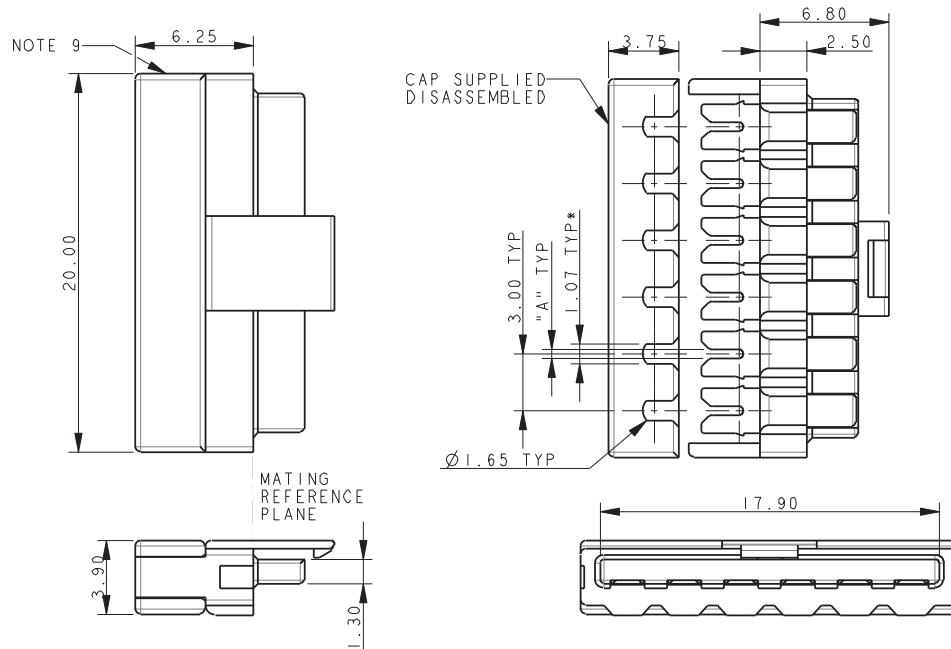

NOTES:

- FOR MORE INFORMATION REFER TO PRODUCT SPEC 201-01-119.
FOR WIRE ASSEMBLY REFER TO APPLICATION NOTES 201-01-123.
- WIRE STOP CAP, WITH STOP FACE ON ONE SIDE TO PROTECT END OF WIRE.
- CAP ACTS AS WIRE ASSEMBLY TOOL. WIRE PREFIT TO CAP, NARROW SLOT TO GRIP WIRE, PERMANENT ASSEMBLY.
- GENERAL TOLERANCE ± 0.20 UNLESS SPECIFIED.
- INSULATOR MATERIAL: NYLON 46, GLASS FILLED, UL94 V-0. COLOR REFER TO PAGE 24.
- CONTACT MATERIAL: COPPER ALLOY, PLATING NICKEL BASE ALL OVER, GOLD ON CONTACT, TIN ON IDC.
- PACKING IN TAPE AND REEL. QTY PER REEL 700, POCKET CONTAINS 1 CONNECTOR AND 1 CAP.
- WIRE GAUGE OPTIONS, SEE TABLE.
- SHOWN WITH WIRE ENTRY FROM UNDERSIDE, CAP CAN BE ASSEMBLED FOR EITHER TOP OR UNDERSIDE WIRE ENTRY.
- ASSEMBLY AIDS, REFER TO PAGE 35.

Wire Gauge	Code (Page 24)	Dimension A	Wire Insulation Diameter
22AWG (Stranded Wire)	122	0.47	1.10 to 1.60
24AWG (Stranded Wire)	132	0.37	1.10 to 1.60

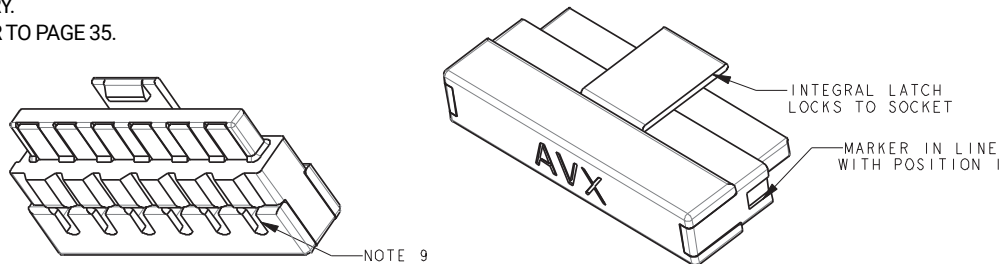

PACKING DETAILS CAP AND CONNECTOR SUPPLIED TOGETHER (2 PARTS)

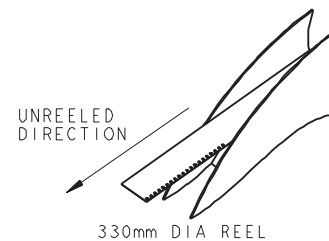
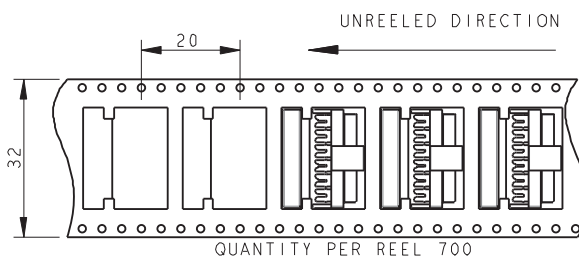

IDC Plug: 14-9159-WTB

Assembly Support Block / Insertion Tool

PLUG-WIRED – ASSEMBLY SUPPORT BLOCK

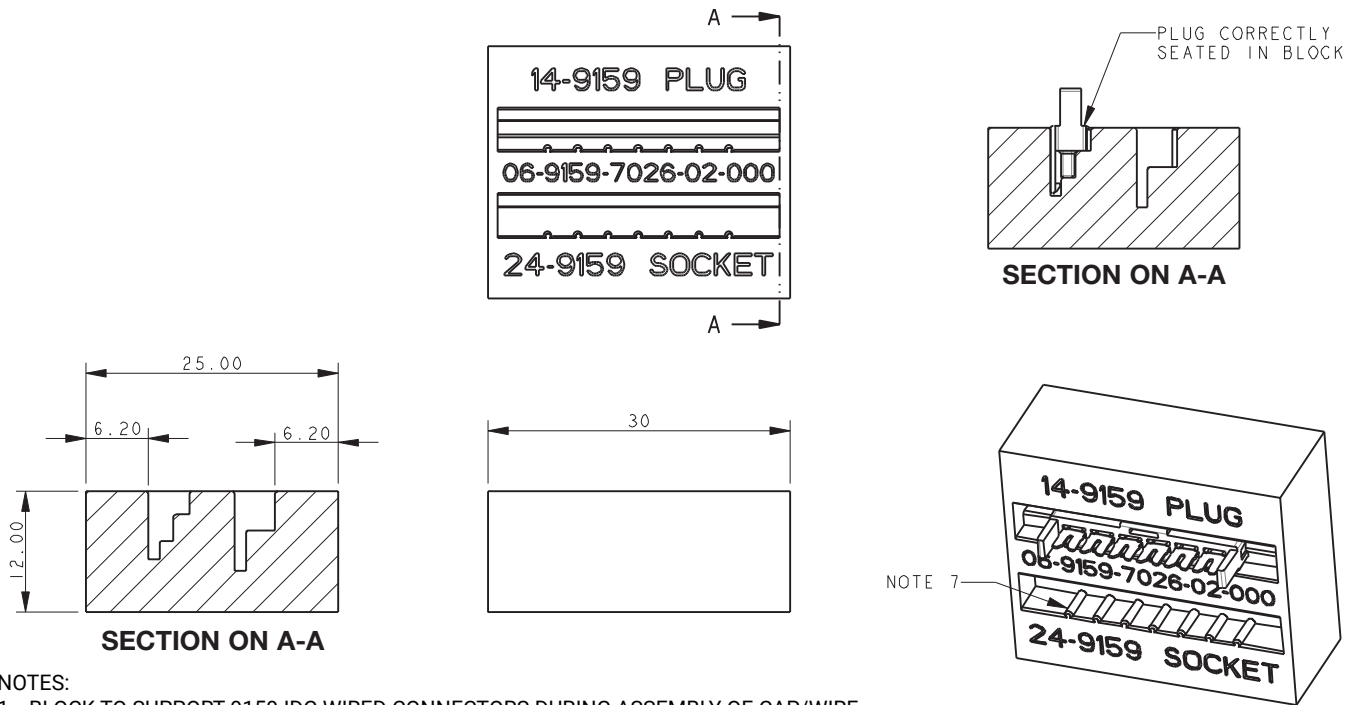

NOTES:

1. BLOCK TO SUPPORT 9159 IDC WIRED CONNECTORS DURING ASSEMBLY OF CAP/WIRE.
2. PART NUMBER 06-9159-7026-01-000, MATERIAL ALUMINUM. PART NUMBER 06-9159-7026-02-000, MATERIAL NYLON 46.
3. CAN BE USED WITH EITHER THE PLUG OR SOCKET CONNECTORS, USE THE CORRECT SLOT AS IDENTIFIED.
4. FOR FULL WIRE ASSEMBLY DETAILS REFER TO APPLICATION NOTES 201-01-123.
5. ONLY A SIMPLE FLAT BOTTOMED TOOL REQUIRED TO PUSH THE CAP DOWN (NOT SUPPLIED.)
6. ALL DIMENSIONS ± 0.20 UNLESS TOLERANCED.
7. 06-9159-7026-02-000 HAS RIBS TO HELP LOCATE CONTACT/INSULATOR SUB-ASSEMBLY.

PLUG-WIRED – WIRE INSERTION TOOL

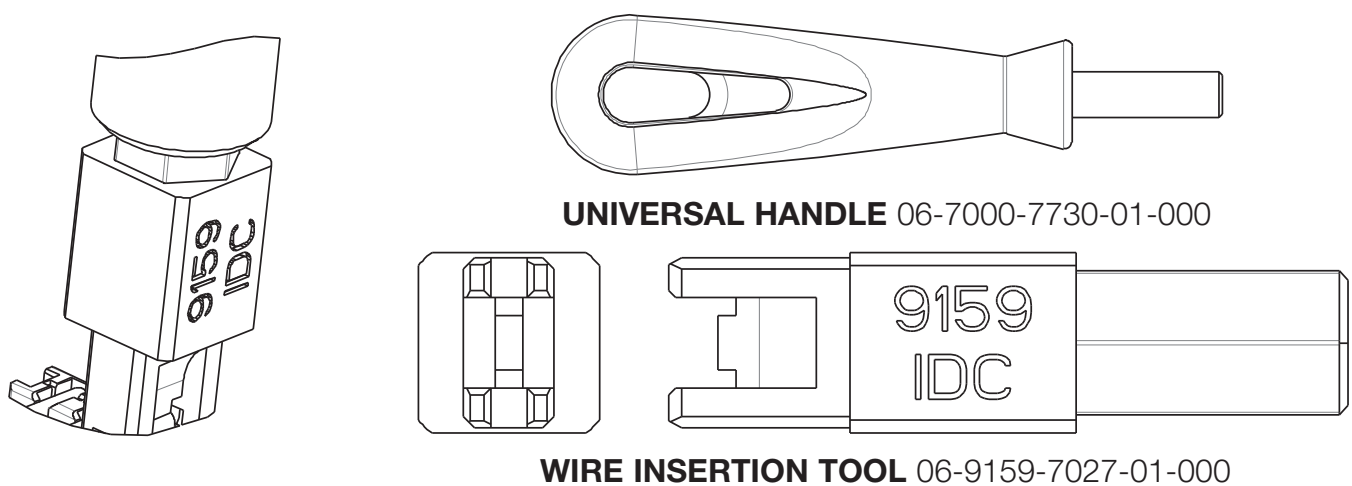

NOTES:

1. TOOL 06-9159-7027-01-000 TO INSERT WIRES INTO CAP.
2. FOR USE WITH UNIVERSAL HANDLE 06-7000-7720-01-000.
3. CAN BE USED WITH BOTH THROUGH WIRE AND WIRE STOP CAPS.
4. REFER TO APPLICATION NOTES 201-01-123 FOR FURTHER DETAILS.

IDC Plug: 14-9159-WTB

Assembly

PLUG-WIRED – ASSEMBLY

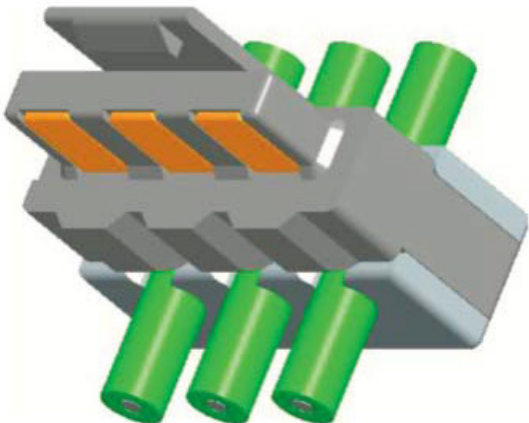

THROUGH WIRE

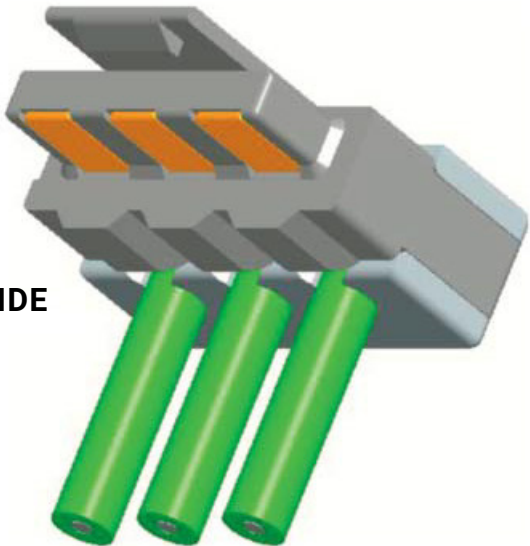

**WIRED STOP
WIRE ENTRY UNDERSIDE**



**WIRED STOP
WIRE ENTRY TOP**

Horizontal Socket: 20-9159-BTB

General Description



The 9159 series of Board-to-Board interconnect system allows two PCB's to be mated end-to-end creating strips of LED lighting. Designed specifically for the unique Solid State Lighting (SSL) market requiring coplanar (horizontal-to-horizontal) PCB mating with a 5 Amp current rating in the smallest package available. These single sided SMT connectors are perfect for both FR4 and metal boards where you need to butt the boards up together to minimize separation. Availability of both white and black insulation colors make them perfect for lighting as well as industrial applications. With sizes from 2p-6p, these high reliability connectors boast gold plated beryllium copper receptacle contacts for harsh environments.

APPLICATIONS

- Coplanar PCB mating in SSL products
- LED linear lighting strips
- Application Notes: refer to 201-01-123

FEATURES AND BENEFITS

- Single sided SMT: supports FR4 and metal PCB's
- 5 Amp current rating: exceeds general market needs
- 5.5mm mated width: minimizes PCB space to decrease LED pitch
- Gold plated BeCu spring contacts: reliability for harsh environments
- Optional retaining clip: provides positive connector mating during vibration
- Available in white: supports SSL market preferences

ELECTRICAL

- Current Rating: 5 Amps / Contact
- Voltage Rating: 125 VAC

ENVIRONMENTAL

- Operating Temperature: -40°C to +125°C

MECHANICAL

- Insulator Material: Nylon: VL94V0
- Contact Material: BeCu / Phos Bronze
- Plating: Gold / Tin over Nickel
- Durability: 10 Cycles

HOW TO ORDER

20
Prefix
Socket

9159
Series

00X
Number of Ways

Code	No of Ways	Details
002	2	Page 38
003	3	Page 39
004	4	Page 40
005	5	Page 41
006	6	Page 42

1
2 Part
PCB Strip
Connector

01
Connector
Pitch
01 = 3mm

9
Color/Approval

Code	Color	Approval
9	White	UL Approved

16
Plating Option

Code	Contact	Bracket
16	Gold in Contact Area Gold on Solder Tail	Tin all over

Certification: UL File #E90723



Horizontal Socket: 20-9159-BTB

2 Position

SOCKET 2 WAY 2 PART PCB STRIP CONNECTOR

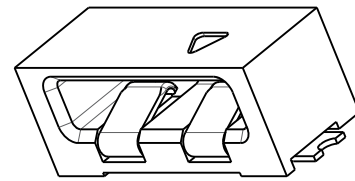
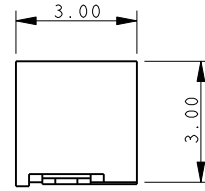
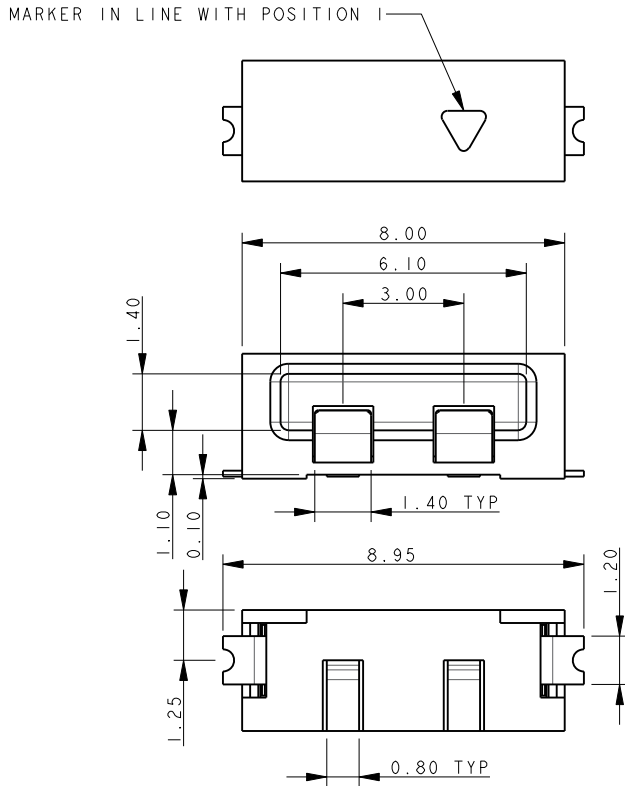

NOTES:

1. FOR MORE INFORMATION REFER TO PRODUCT SPEC 201-01-119.
2. DIMENSIONS ARE REFERENCE DIMENSIONS UNLESS TOLERANCES.
3. INSULATOR MATERIAL: NYLON 46. COLOR REFER TO PAGE 37.
4. CONTACT MATERIAL: COPPER ALLOY, GOLD OVER NICKEL.
5. BRACKETS: COPPER ALLOY, TIN PLATED.
6. OUTLINE OF CONNECTOR.
7. PACKING TAPE AND REEL, QUANTITY 1400 PER REEL.

2 WAY PCB BOARD LAYOUT

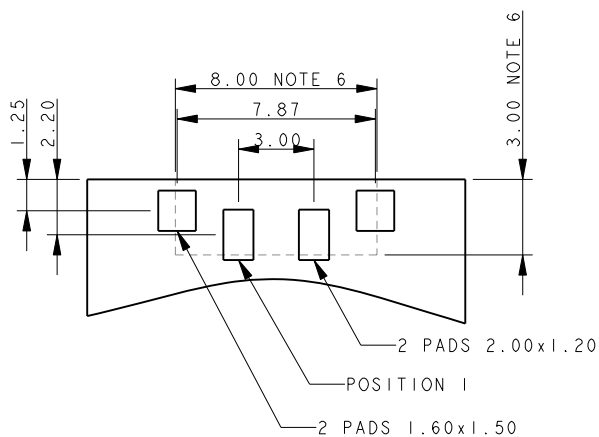

PACKING DETAILS

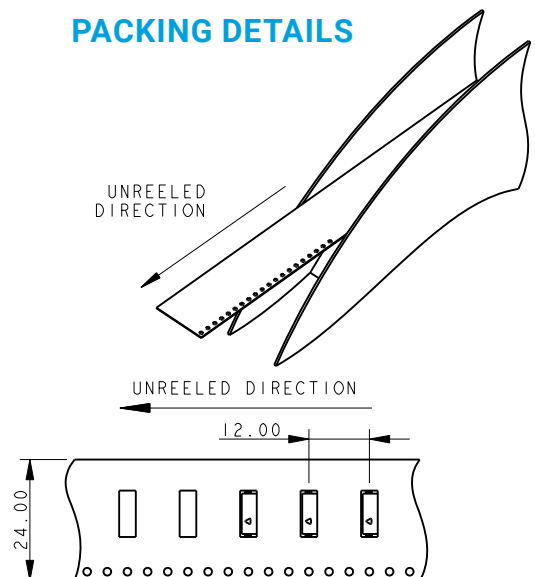

Horizontal Socket: 20-9159-BTB

3 Position

SOCKET 3 WAY 2 PART PCB STRIP CONNECTOR

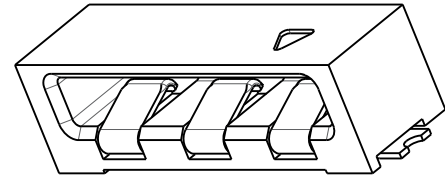
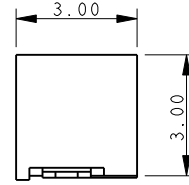
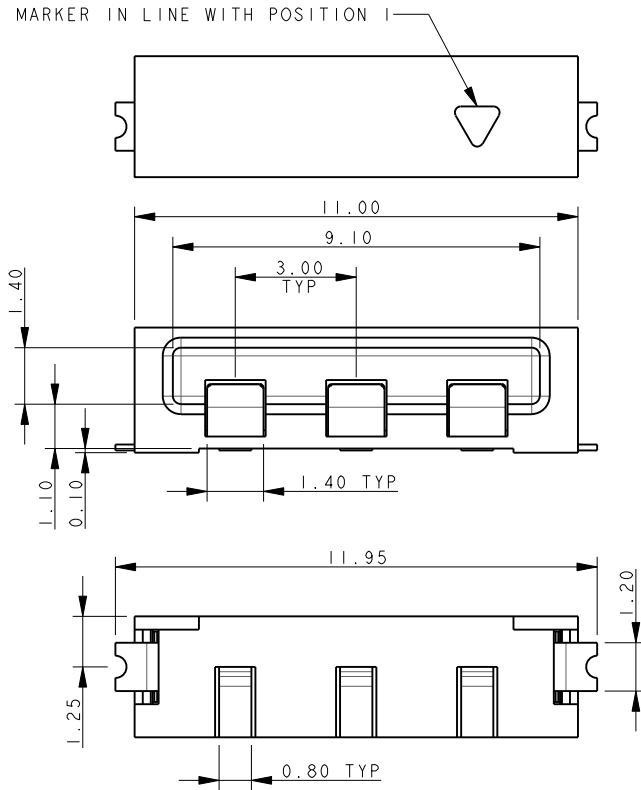

NOTES:

1. FOR MORE INFORMATION REFER TO PRODUCT SPEC 201-01-119.
2. DIMENSIONS ARE REFERENCE DIMENSIONS UNLESS TOLERANCES.
3. INSULATOR MATERIAL: NYLON 46. COLOR REFER TO PAGE 37.
4. CONTACT MATERIAL: COPPER ALLOY, GOLD OVER NICKEL.
5. BRACKETS: COPPER ALLOY, TIN PLATED.
6. OUTLINE OF CONNECTOR.
7. PACKING TAPE AND REEL, QUANTITY 1400 PER REEL.

3 WAY PCB BOARD LAYOUT

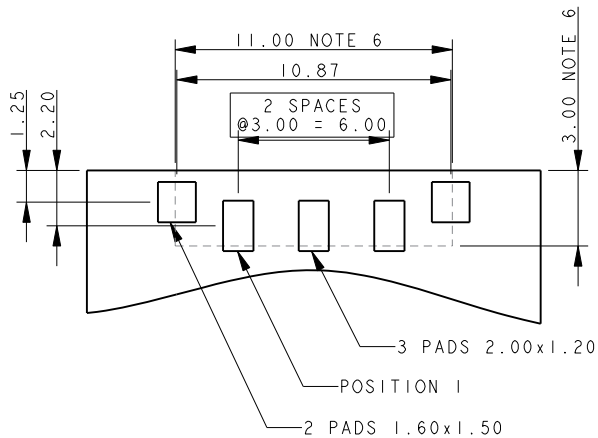

PACKING DETAILS

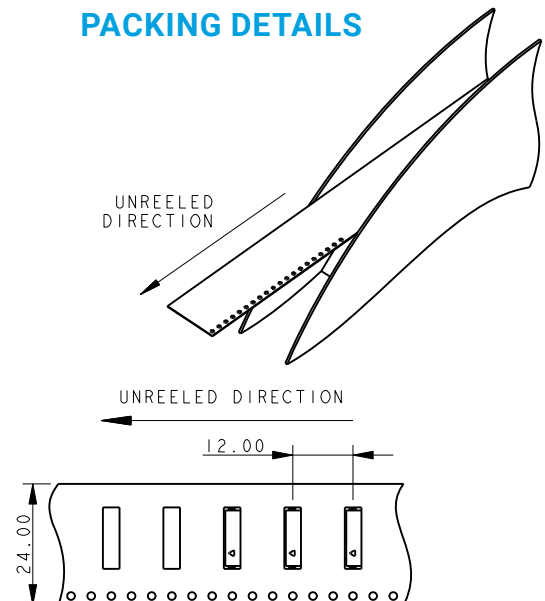

Horizontal Socket: 20-9159-BTB

4 Position

SOCKET 4 WAY 2 PART PCB STRIP CONNECTOR

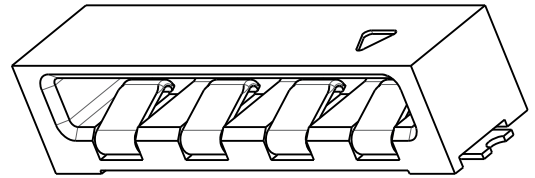
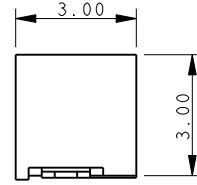
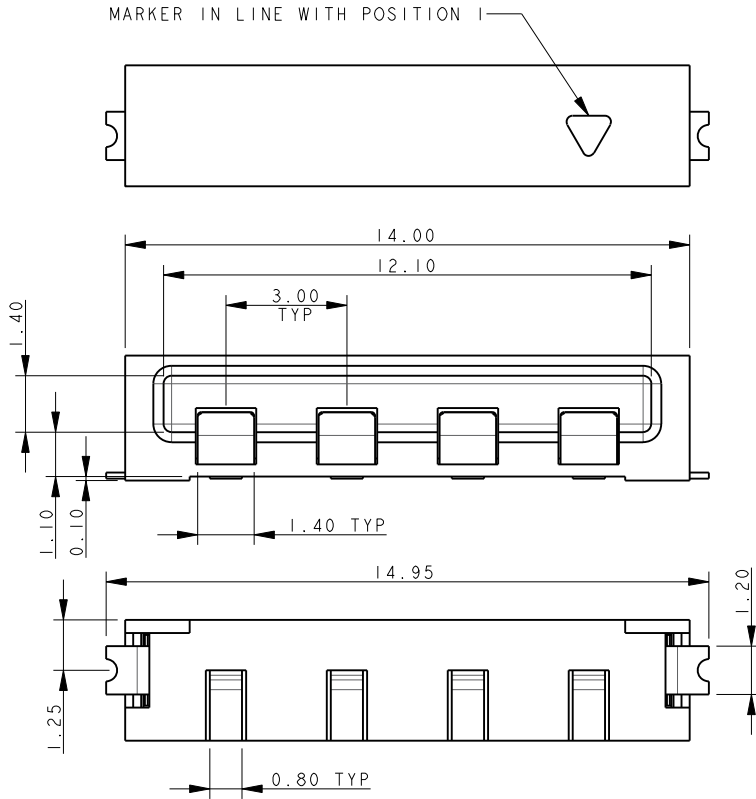

NOTES:

1. FOR MORE INFORMATION REFER TO PRODUCT SPEC 201-01-119.
2. DIMENSIONS ARE REFERENCE DIMENSIONS UNLESS TOLERANCES.
3. INSULATOR MATERIAL: NYLON 46. COLOR REFER TO PAGE 37.
4. CONTACT MATERIAL: COPPER ALLOY, GOLD OVER NICKEL.
5. BRACKETS: COPPER ALLOY, TIN PLATED.
6. OUTLINE OF CONNECTOR.
7. PACKING TAPE AND REEL, QUANTITY 1400 PER REEL.

4 WAY PCB BOARD LAYOUT

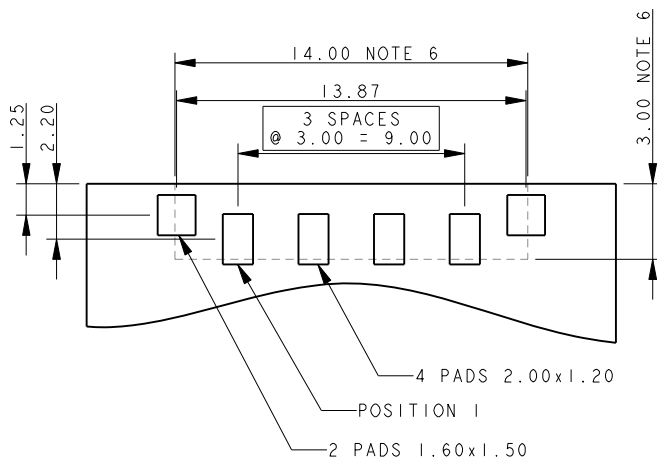

PACKING DETAILS

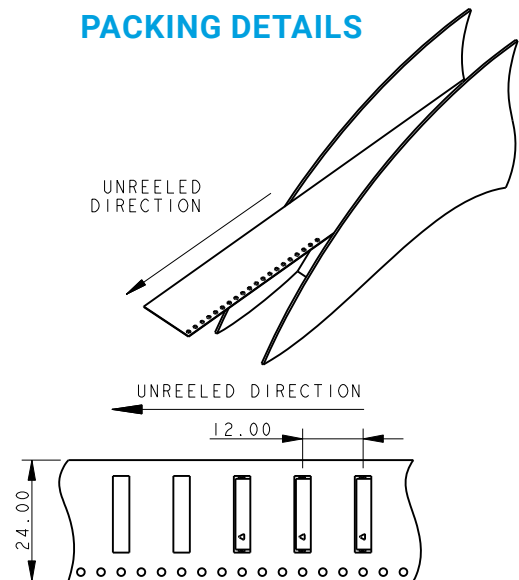

Horizontal Socket: 20-9159-BTB

5 Position

SOCKET 5 WAY 2 PART PCB STRIP CONNECTOR

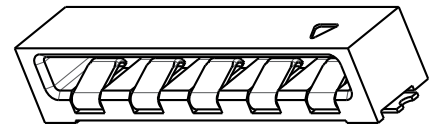
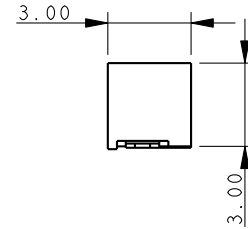
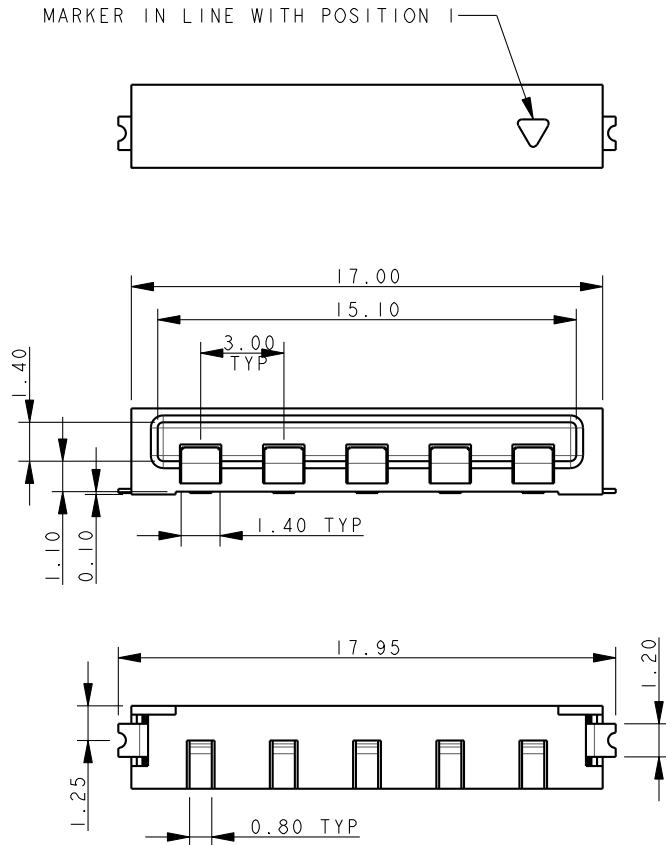

NOTES:

1. FOR MORE INFORMATION REFER TO PRODUCT SPEC 201-01-119.
2. DIMENSIONS ARE REFERENCE DIMENSIONS UNLESS TOLERANCES.
3. INSULATOR MATERIAL: NYLON 46. COLOR REFER TO PAGE 37.
4. CONTACT MATERIAL: COPPER ALLOY, GOLD OVER NICKEL.
5. BRACKETS: COPPER ALLOY, TIN PLATED.
6. OUTLINE OF CONNECTOR.
7. PACKING TAPE AND REEL, QUANTITY 1400 PER REEL.

5 WAY PCB BOARD LAYOUT

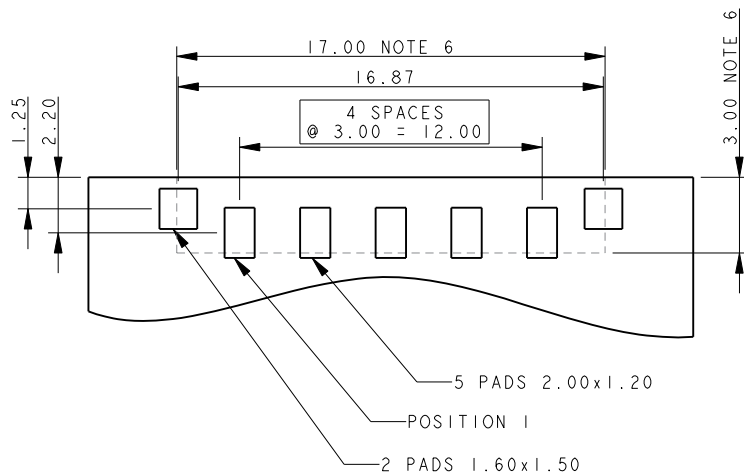

PACKING DETAILS

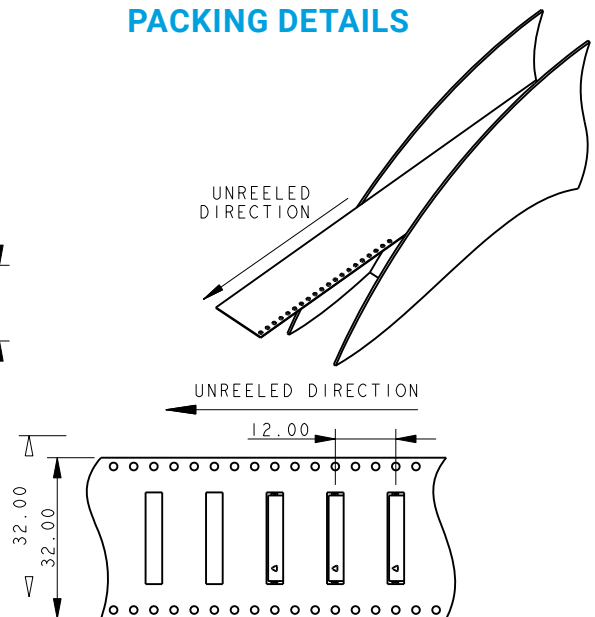

Horizontal Socket: 20-9159-BTB

6 Position

SOCKET 6 WAY 2 PART PCB STRIP CONNECTOR

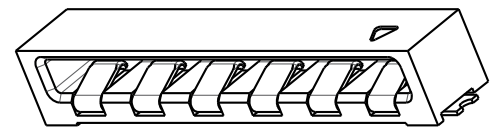
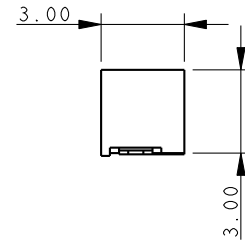
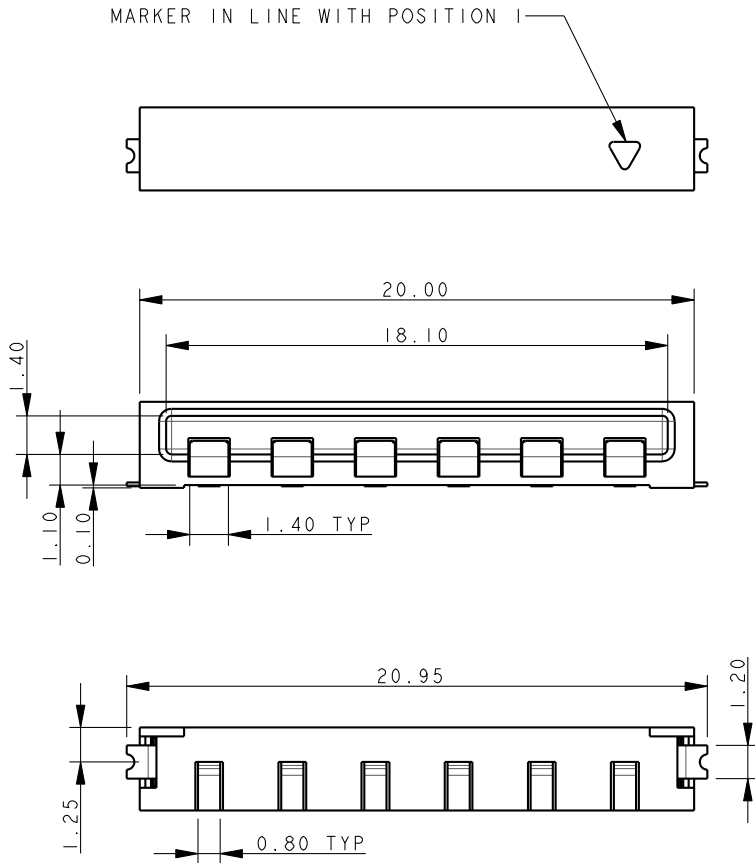

NOTES:

1. FOR MORE INFORMATION REFER TO PRODUCT SPEC 201-01-119.
2. DIMENSIONS ARE REFERENCE DIMENSIONS UNLESS TOLERANCES.
3. INSULATOR MATERIAL: NYLON 46. COLOR REFER TO PAGE 37.
4. CONTACT MATERIAL: COPPER ALLOY, GOLD OVER NICKEL.
5. BRACKETS: COPPER ALLOY, TIN PLATED.
6. OUTLINE OF CONNECTOR.
7. PACKING TAPE AND REEL, QUANTITY 1400 PER REEL.

6 WAY PCB BOARD LAYOUT

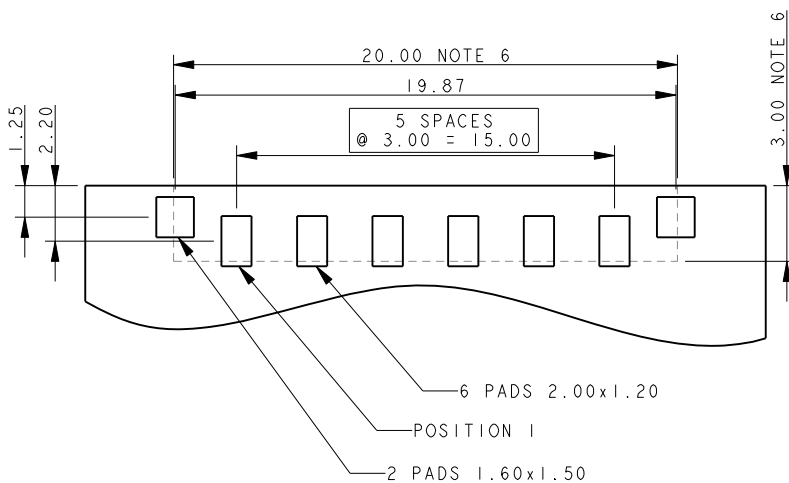

PACKING DETAILS

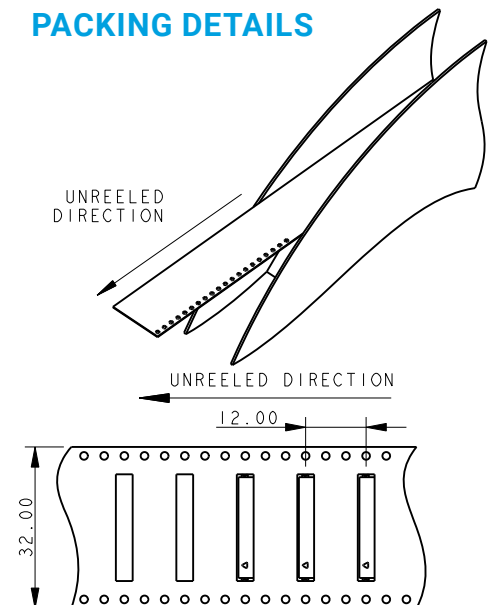

Top Load Socket: 22-9159-BTB

General Description



The 9159 series of Board-to-Board interconnect system allows two PCB's to be mated end-to-end creating strips of LED lighting. Designed specifically for the unique Solid State Lighting (SSL) market requiring coplanar (horizontal-to-horizontal) PCB mating with a 5 Amp current rating in the smallest package available. The top loading socket allows complete PCB's to be replaced in the field without having to disassemble the entire strip of boards. The connector has a two part insulator whereby the top of the connector will slide open allowing the plug connector to be pulled out either vertically or at a slight angle. Once the PCB is replaced, the cover is slid back like a Zero Insertion Force (ZIF) connector to the closed position. The PCB layout is identical to the standard horizontal socket to maintain family commonality at the PCB level.

APPLICATIONS

- Coplanar PCB mating in SSL products
- LED linear lighting strips
- Application Notes: refer to 201-01-123

FEATURES AND BENEFITS

- Slide open top: allows field reparability at the light fixture level
- Mates with standard horizontal or cabled plug: no need to change any connectors
- 5 Amp current rating: exceeds general market needs
- Gold plated BeCu spring contacts: reliability for harsh environments
- Available in white: supports SSL market preferences

ELECTRICAL

- Current Rating: 5 Amps / Contact
- Voltage Rating: 125 VAC

ENVIRONMENTAL

- Operating Temperature: -40°C to +125°C

MECHANICAL

- Insulator Material: Nylon: VL94V0
- Contact Material: BeCu / Phos Bronze
- Plating: Gold / Tin over Nickel
- Durability: 10 Cycles

HOW TO ORDER

22
Prefix
Socket
Top Loading

9159
Series

00X
Number of Ways

Code	No of Ways	Details
002	2	Page 44
003	3	Page 45
004	4	Page 46
005	5	Page 47
006	6	Page 48

1
2 Part
PCB Strip
Connector

01
Connector
Pitch
01 = 3mm

9
Color/Approval

Code	Color	Approval
9	White	UL Approved

16
Plating Option

Code	Contact	Bracket
16	Gold in Contact Area Gold on Solder Tail	Tin all over

Certification: UL File #E90723



Top Load Socket: 22-9159-BTB

2 Position

SOCKET TOP LOADING 2 WAY 2 PART PCB STRIP CONNECTOR

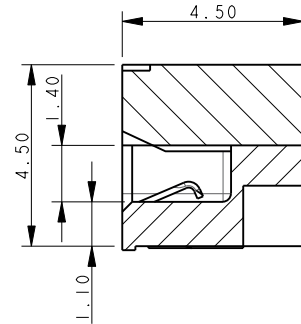
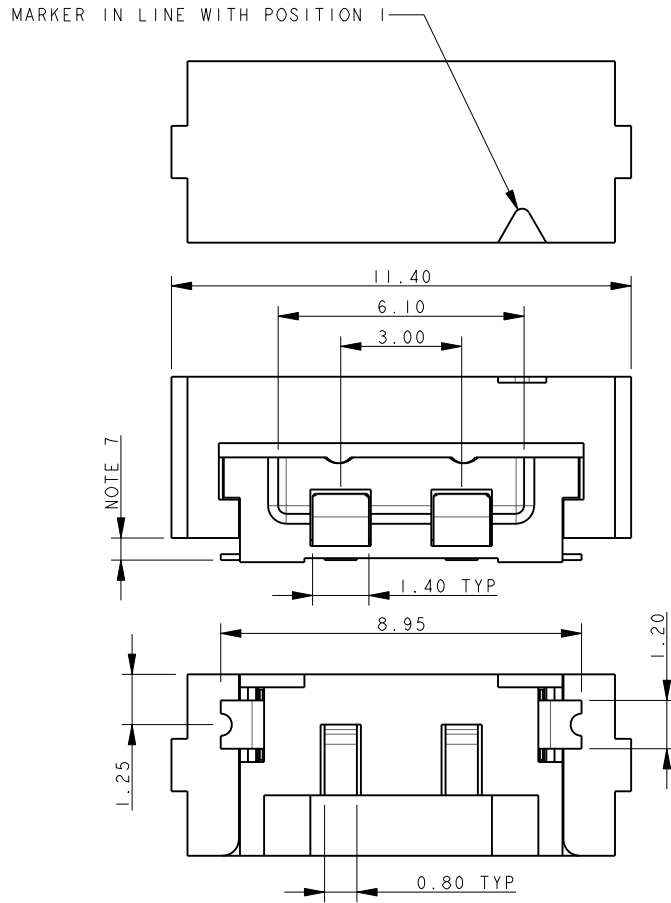

NOTES:

1. FOR MORE INFORMATION REFER TO PRODUCT SPEC 201-01-119.
2. DIMENSIONS ARE REFERENCE DIMENSIONS UNLESS TOLERANCES.
3. INSULATOR MATERIAL: NYLON 46. COLOR REFER TO PAGE 43.
4. CONTACT MATERIAL: COPPER ALLOY, GOLD OVER NICKEL.
5. BRACKETS: COPPER ALLOY, TIN PLATED.
6. OUTLINE OF CONNECTOR.
7. RESTRICTED COMPONENT HEIGHT UNDER CATCH, 2.20MM MAXIMUM.
8. RESTRICTED COMPONENT HEIGHT UNDER CATCH, 0.40MM MAXIMUM.
9. PACKING TAPE AND REEL, QUANTITY 1400 PER REEL.

2 WAY PCB BOARD LAYOUT

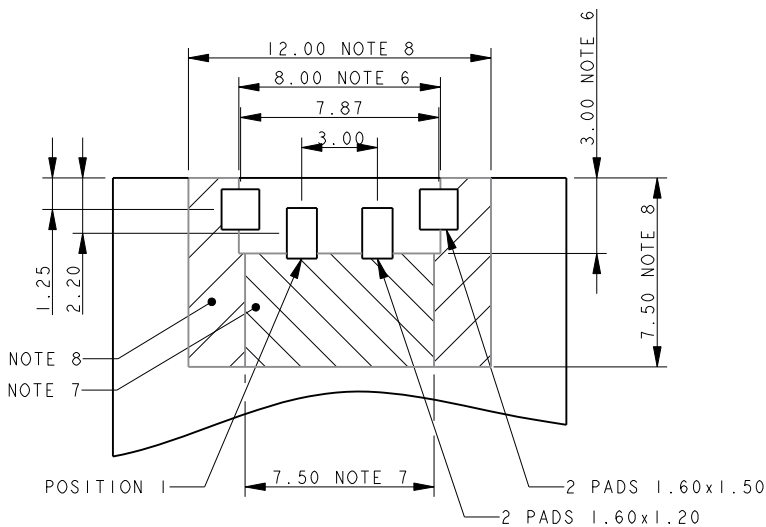

PACKING DETAILS

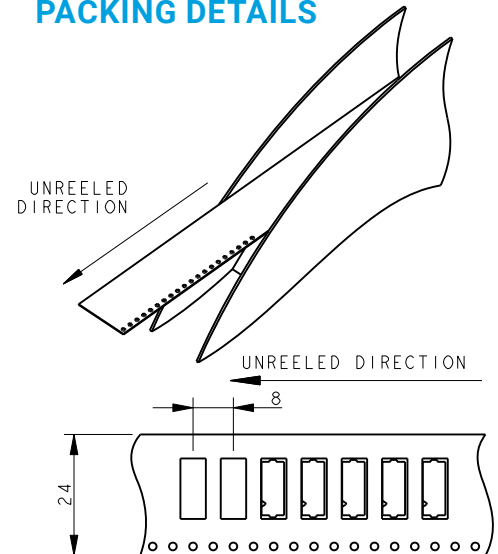

Top Load Socket: 22-9159-BTB

3 Position

SOCKET TOP LOADING 3 WAY 2 PART PCB STRIP CONNECTOR

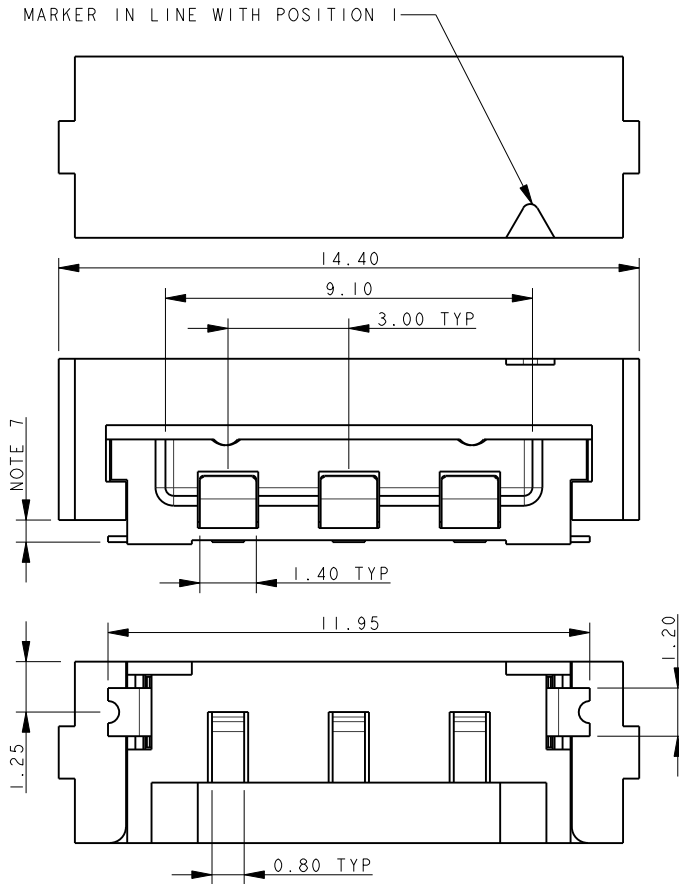

NOTES:

1. FOR MORE INFORMATION REFER TO PRODUCT SPEC 201-01-119.
2. DIMENSIONS ARE REFERENCE DIMENSIONS UNLESS TOLERANCES.
3. INSULATOR MATERIAL: NYLON 46. COLOR REFER TO PAGE 43.
4. CONTACT MATERIAL: COPPER ALLOY, GOLD OVER NICKEL.
5. BRACKETS: COPPER ALLOY, TIN PLATED.
6. OUTLINE OF CONNECTOR.
7. RESTRICTED COMPONENT HEIGHT UNDER CATCH, 2.20MM MAXIMUM.
8. RESTRICTED COMPONENT HEIGHT UNDER CATCH, 0.40MM MAXIMUM.
9. PACKING TAPE AND REEL, QUANTITY 1400 PER REEL.

3 WAY PCB BOARD LAYOUT

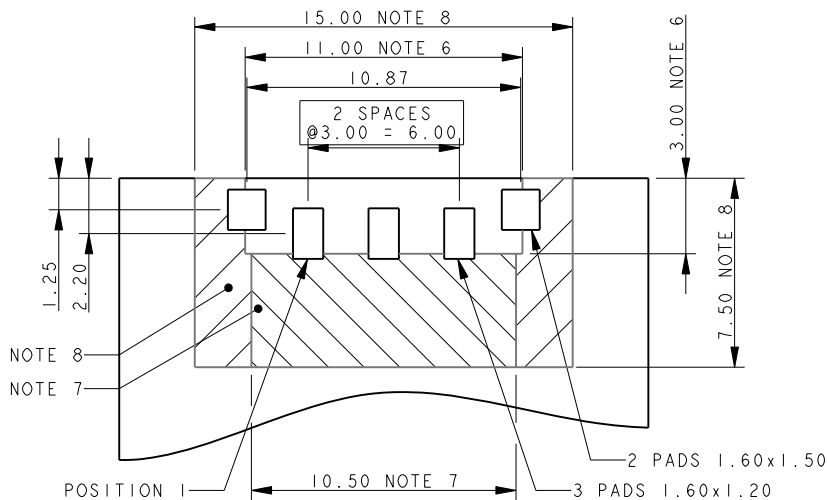

PACKING DETAILS

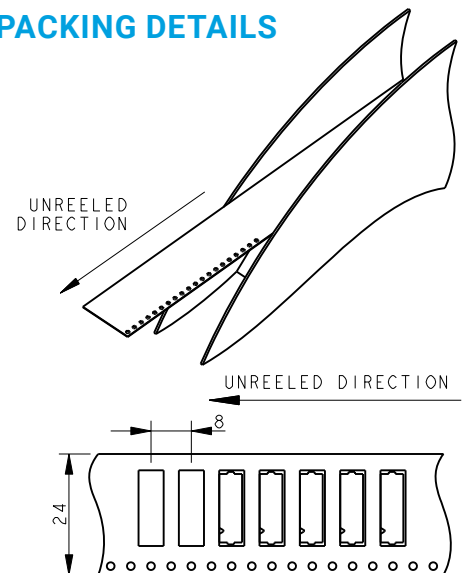

Top Load Socket: 22-9159-BTB

4 Position

SOCKET TOP LOADING 4 WAY 2 PART PCB STRIP CONNECTOR

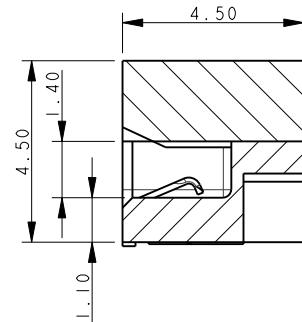
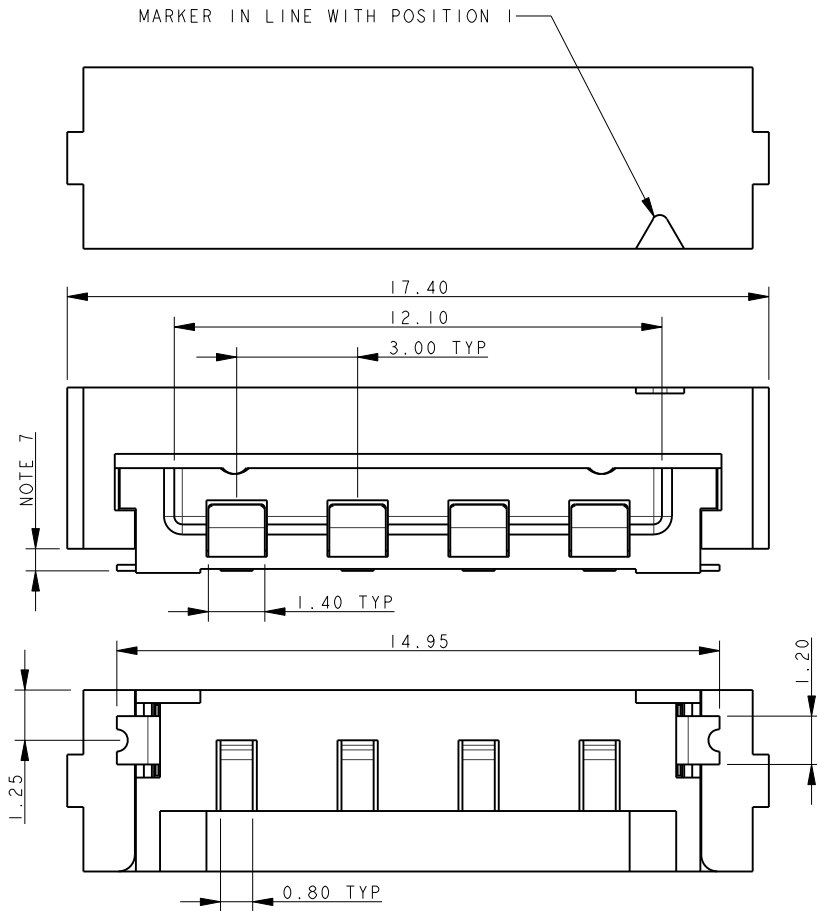

NOTES:

1. FOR MORE INFORMATION REFER TO PRODUCT SPEC 201-01-119.
2. DIMENSIONS ARE REFERENCE DIMENSIONS UNLESS TOLERANCES.
3. INSULATOR MATERIAL: NYLON 46. COLOR REFER TO PAGE 43.
4. CONTACT MATERIAL: COPPER ALLOY, GOLD OVER NICKEL.
5. BRACKETS: COPPER ALLOY, TIN PLATED.
6. OUTLINE OF CONNECTOR.
7. RESTRICTED COMPONENT HEIGHT UNDER CATCH, 2.20MM MAXIMUM.
8. RESTRICTED COMPONENT HEIGHT UNDER CATCH, 0.40MM MAXIMUM.
9. PACKING TAPE AND REEL, QUANTITY 1400 PER REEL.

4 WAY PCB BOARD LAYOUT

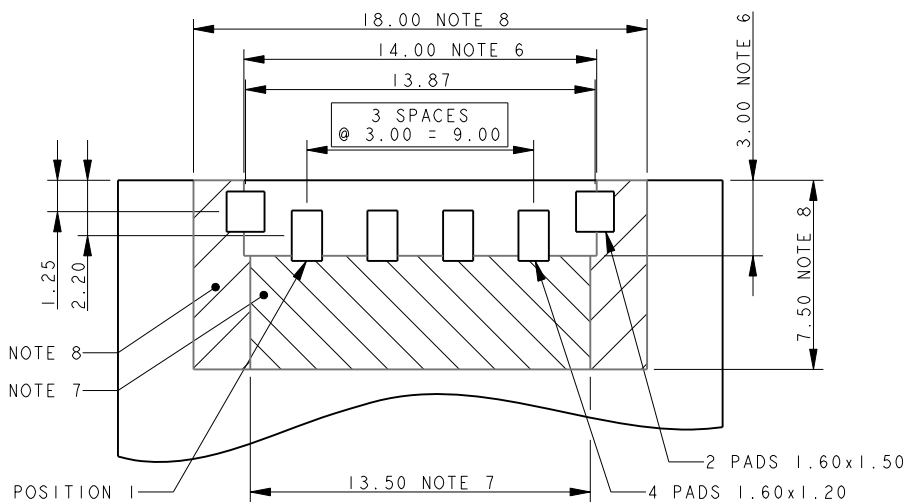

PACKING DETAILS

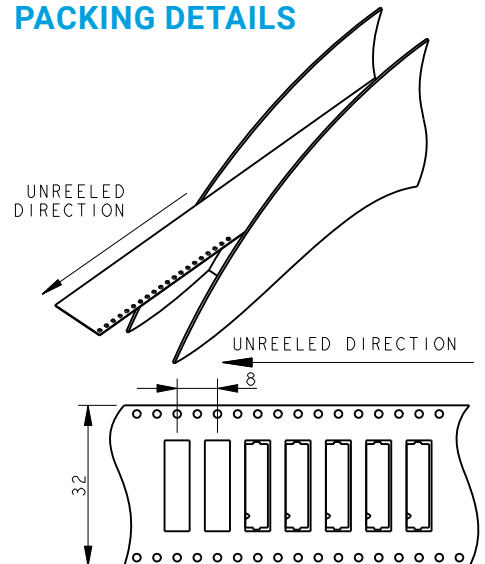

Top Load Socket: 22-9159-BTB

5 Position

SOCKET TOP LOADING 5 WAY 2 PART PCB STRIP CONNECTOR

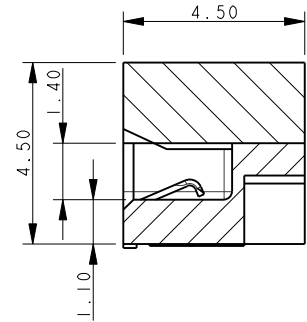
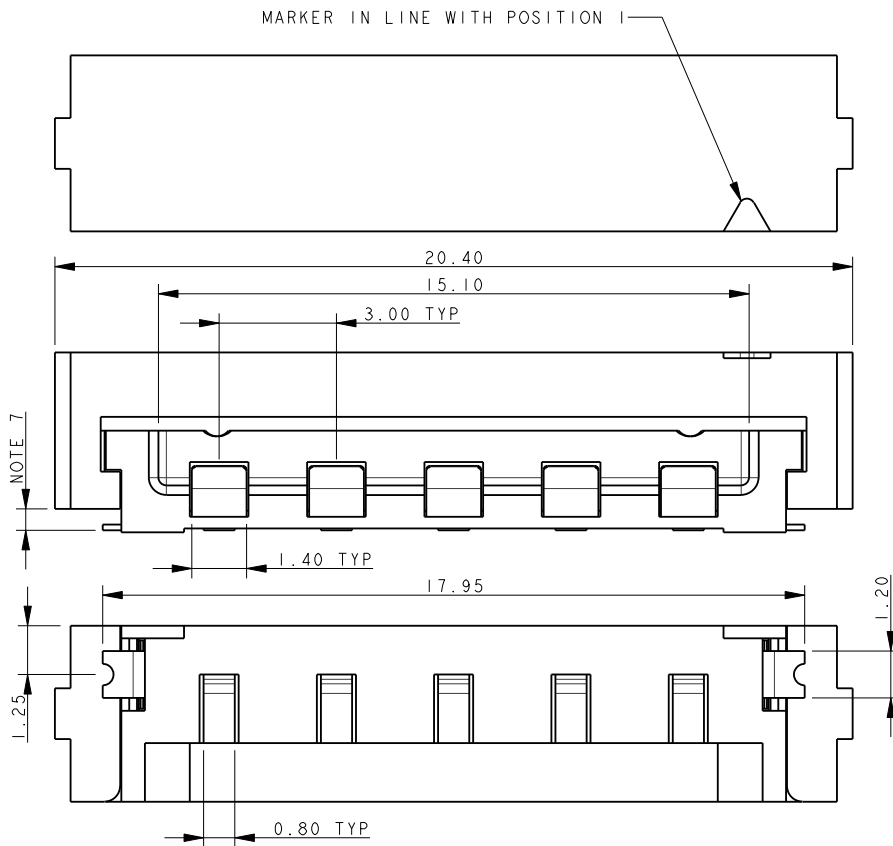

NOTES:

1. FOR MORE INFORMATION REFER TO PRODUCT SPEC 201-01-119.
2. DIMENSIONS ARE REFERENCE DIMENSIONS UNLESS TOLERANCES.
3. INSULATOR MATERIAL: NYLON 46. COLOR REFER TO PAGE 43.
4. CONTACT MATERIAL: COPPER ALLOY, GOLD OVER NICKEL.
5. BRACKETS: COPPER ALLOY, TIN PLATED.
6. OUTLINE OF CONNECTOR.
7. RESTRICTED COMPONENT HEIGHT UNDER CATCH, 2.20MM MAXIMUM.
8. RESTRICTED COMPONENT HEIGHT UNDER CATCH, 0.40MM MAXIMUM.
9. PACKING TAPE AND REEL, QUANTITY 1400 PER REEL

5 WAY PCB BOARD LAYOUT

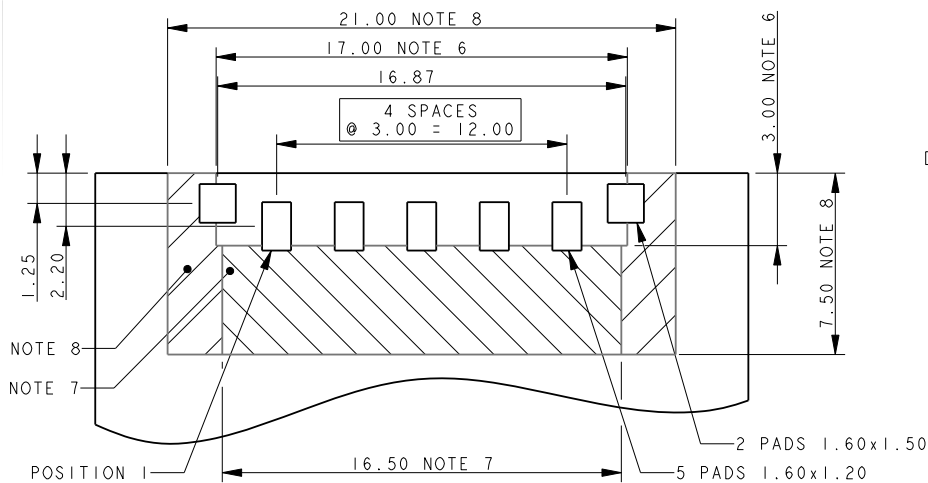

PACKING DETAILS

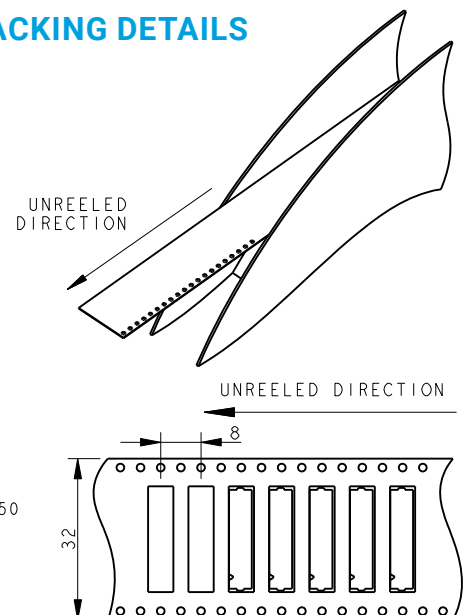

Top Load Socket: 22-9159-BTB

6 Position

SOCKET TOP LOADING 6 WAY 2 PART PCB STRIP CONNECTOR

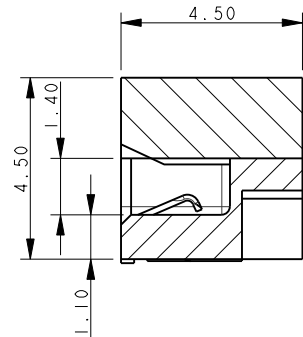
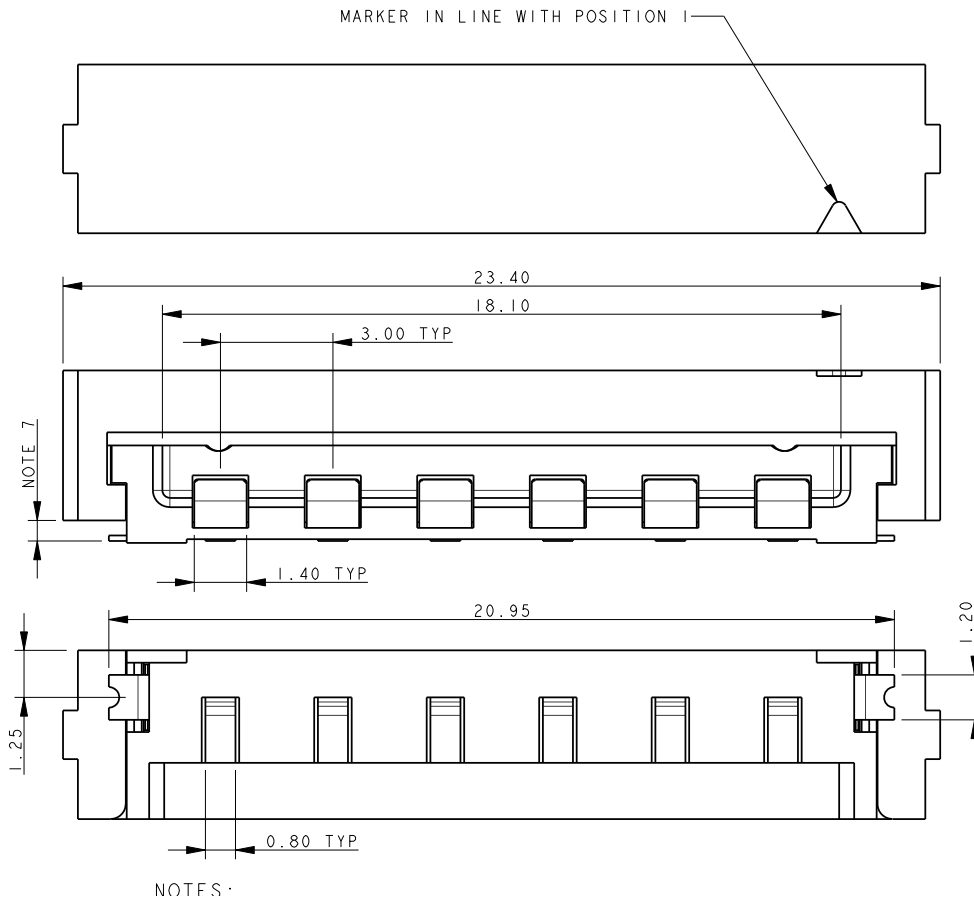

NOTES:

1. FOR MORE INFORMATION REFER TO PRODUCT SPEC 201-01-119.
2. DIMENSIONS ARE REFERENCE DIMENSIONS UNLESS TOLERANCES.
3. INSULATOR MATERIAL: NYLON 46. COLOR REFER TO PAGE 43.
4. CONTACT MATERIAL: COPPER ALLOY, GOLD OVER NICKEL.
5. BRACKETS: COPPER ALLOY, TIN PLATED.
6. OUTLINE OF CONNECTOR.
7. RESTRICTED COMPONENT HEIGHT UNDER CATCH, 2.20MM MAXIMUM.
8. RESTRICTED COMPONENT HEIGHT UNDER CATCH, 0.40MM MAXIMUM.
9. PACKING TAPE AND REEL, QUANTITY 1400 PER REEL.

6 WAY PCB BOARD LAYOUT

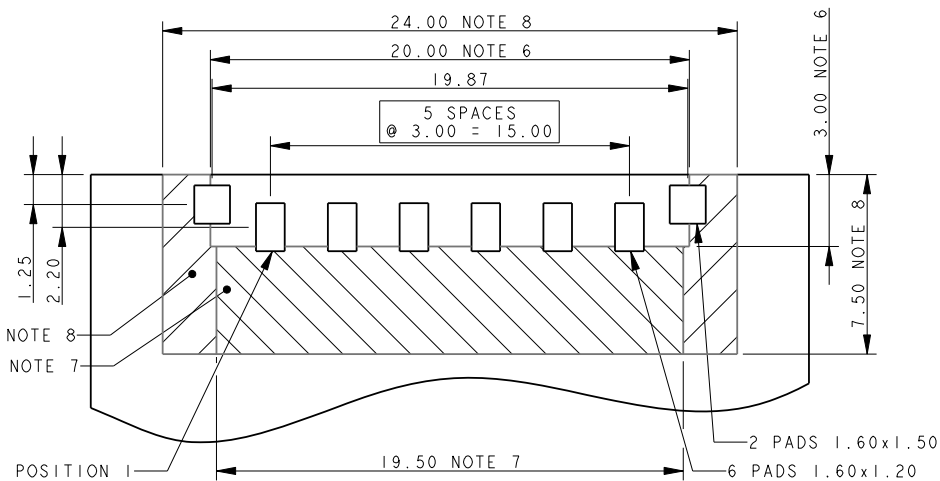

PACKING DETAILS

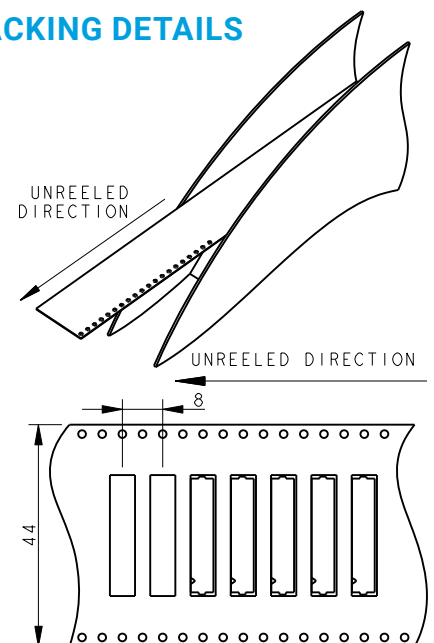

Top Load Socket: 22-9159-BTB

Assembly

CONNECTOR ASSEMBLY



COVER FORWARD (LOCKED)



COVER SLID BACK



DROP PCB ASSEMBLY ONTO MATING CONNECTORS

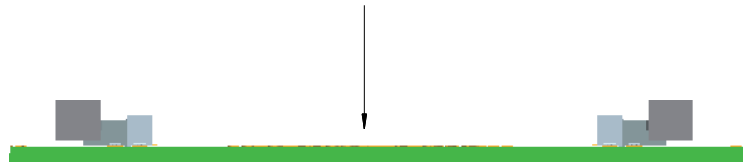

IDC Socket: 24-9159 WTB

General Description



KYOCERA AVX developed the 9159 Series of SMT connectors for co-planar PCB mating for the challenging Solid State Lighting (SSL) market. These connectors needed to be small, low in height, carry up to 5 Amps/contact and then function up to 125C for extended periods. This application has been very unique to the SSL market where PCB's are stacked end-to-end to create linear strip lighting in everything from office to transportation applications where products are exposed to harsh mechanical and environmental environments.

The IDC cable socket connector allows for 22-24AWG discrete or cabled wires to be easily and reliability terminated into a 9159 standard interface plug connector. This will allow power and signals to be connectors onto a PCB socket connector while providing positive latching. The wire assembly support block allows for 2 through 6 wires to be terminated all in one step with any standard bench top press. IDC covers provide both through (daisy chain applications) and wire stop termination options.

APPLICATIONS

- Provides Wire-to-Board capabilities to standard 9159 2-Piece connector system
- In conjunction with the IDC plug WTB connector (14-9159), these connectors provide maximum flexibility to bring power and signal wires onto or off of any board level 9159 connector
- Reference application notes 201-01-123
- Reference Product Specification 201-01-119

FEATURES AND BENEFITS

- Mates with standard 9159 horizontal plug, keeping same BTB connector system
- Economical and reliable IDC wire termination
- Gold plated BeCu contact system for high reliability in harsh environments
- Integrally molded latch offers positive latching after mating

ELECTRICAL

- Current Rating: 5 Amps / Contact
- Voltage Rating: 125 VAC

ENVIRONMENTAL

- Operating Temperature: -40°C to +125°C

MECHANICAL

- Insulator Material: Nylon: VL94V0
- Contact Material: BeCu / Phos Bronze
- Plating: Gold / Tin over Nickel
- Durability: 10 Cycles

HOW TO ORDER

<p>24</p> <p>Prefix Right Angle Wired Socket IDC Terminations</p>	<p>9159</p> <p>Series</p>	<p>00X</p> <p>Number of Ways</p> <table border="1" style="font-size: 8px; border-collapse: collapse; width: 100%;"> <thead> <tr> <th>Code</th> <th>No of Ways</th> <th>Details</th> </tr> </thead> <tbody> <tr> <td colspan="3">THROUGH WIRE CAP</td> </tr> <tr> <td>002</td> <td>2</td> <td>Page 51</td> </tr> <tr> <td>003</td> <td>3</td> <td>Page 52</td> </tr> <tr> <td>004</td> <td>4</td> <td>Page 53</td> </tr> <tr> <td>005</td> <td>5</td> <td>Page 54</td> </tr> <tr> <td>006</td> <td>6</td> <td>Page 55</td> </tr> <tr> <td colspan="3">WIRE STOP CAP</td> </tr> <tr> <td>002</td> <td>2</td> <td>Page 56</td> </tr> <tr> <td>003</td> <td>3</td> <td>Page 57</td> </tr> <tr> <td>004</td> <td>4</td> <td>Page 58</td> </tr> <tr> <td>005</td> <td>5</td> <td>Page 59</td> </tr> <tr> <td>006</td> <td>6</td> <td>Page 60</td> </tr> </tbody> </table>	Code	No of Ways	Details	THROUGH WIRE CAP			002	2	Page 51	003	3	Page 52	004	4	Page 53	005	5	Page 54	006	6	Page 55	WIRE STOP CAP			002	2	Page 56	003	3	Page 57	004	4	Page 58	005	5	Page 59	006	6	Page 60	<p>1</p> <p>2 Part PCB Strip Connector</p> <p>2 Part Wired IDC Strip Connector</p>	<p>X</p> <p>Wire Gauge</p> <p>2 = 22AWG 3 = 24AWG</p>	<p>2</p> <p>Wire Insulation Diameter</p> <p>ø1.10mm to ø1.60mm</p>	<p>9</p> <p>Color Options</p> <p>9 = UL</p>	<p>X</p> <p>Cap Options</p> <table border="1" style="font-size: 8px; border-collapse: collapse; width: 100%;"> <thead> <tr> <th>Code</th> <th>Cap Option</th> <th>Description</th> </tr> </thead> <tbody> <tr> <td>0</td> <td>Through Wire</td> <td>Allows wires to be terminated at any point</td> </tr> <tr> <td>9</td> <td>Wire Stop</td> <td>Terminates end of wire. End protected with Stop Face</td> </tr> </tbody> </table>	Code	Cap Option	Description	0	Through Wire	Allows wires to be terminated at any point	9	Wire Stop	Terminates end of wire. End protected with Stop Face	<p>6</p> <p>Plating Option</p> <table border="1" style="font-size: 8px; border-collapse: collapse; width: 100%;"> <thead> <tr> <th>Code</th> <th>Contact</th> </tr> </thead> <tbody> <tr> <td>6</td> <td>Gold on Contact Tin on IDC</td> </tr> </tbody> </table>	Code	Contact	6	Gold on Contact Tin on IDC
Code	No of Ways	Details																																																										
THROUGH WIRE CAP																																																												
002	2	Page 51																																																										
003	3	Page 52																																																										
004	4	Page 53																																																										
005	5	Page 54																																																										
006	6	Page 55																																																										
WIRE STOP CAP																																																												
002	2	Page 56																																																										
003	3	Page 57																																																										
004	4	Page 58																																																										
005	5	Page 59																																																										
006	6	Page 60																																																										
Code	Cap Option	Description																																																										
0	Through Wire	Allows wires to be terminated at any point																																																										
9	Wire Stop	Terminates end of wire. End protected with Stop Face																																																										
Code	Contact																																																											
6	Gold on Contact Tin on IDC																																																											



Certification: UL File #E90723

IDC Socket: 24-9159-WTB

2 Position Through Wire Cap

SOCKET WIRED – 2 WAY THROUGH WIRE CAP

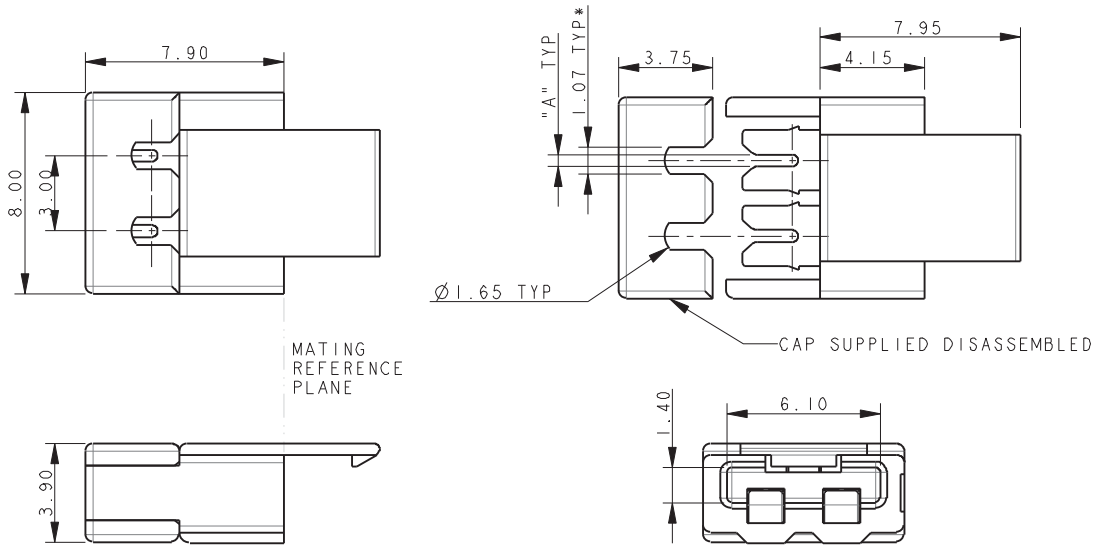

NOTES:

- FOR MORE INFORMATION REFER TO PRODUCT SPEC 201-01-119.
FOR WIRE ASSEMBLY REFER TO APPLICATION NOTES 201-01-123.
- THROUGH WIRE CAP, FOR TERMINATION OF WIRE IN ANY POSITION.
- CAP ACTS AS WIRE ASSEMBLY TOOL. WIRE PREFIT TO CAP, NARROW SLOT TO GRIP WIRE, PERMANENT ASSEMBLY.
- GENERAL TOLERANCE ± 0.20 UNLESS SPECIFIED.
- INSULATOR MATERIAL: NYLON 46, GLASS FILLED, UL94 V-0. COLOR REFER TO PAGE 50.
- CONTACT MATERIAL: COPPER ALLOY, PLATING NICKEL BASE ALL OVER, GOLD ON CONTACT, TIN ON IDC.
- PACKING IN TAPE AND REEL. QTY PER REEL 700, POCKET CONTAINS 1 CONNECTOR AND 1 CAP.
- WIRE GAUGE OPTIONS, SEE TABLE.
- ASSEMBLY AIDS, REFER TO PAGE 61.

Wire Gauge	Code (Page 50)	Dimension A	Wire Insulation Diameter
22AWG (Stranded Wire)	122	0.47	1.10 to 1.60
24AWG (Stranded Wire)	132	0.37	1.10 to 1.60

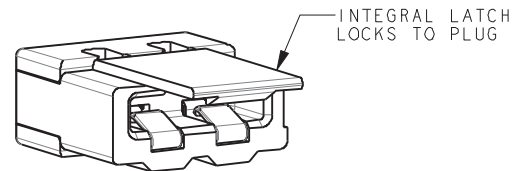
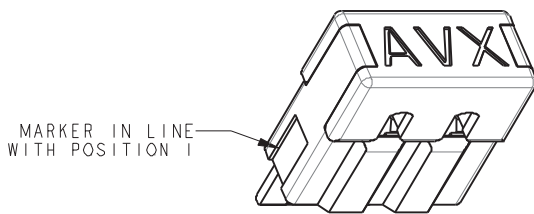

PACKING DETAILS CAP AND CONNECTOR SUPPLIED TOGETHER (2 PARTS)

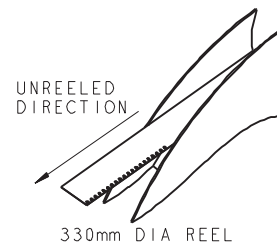
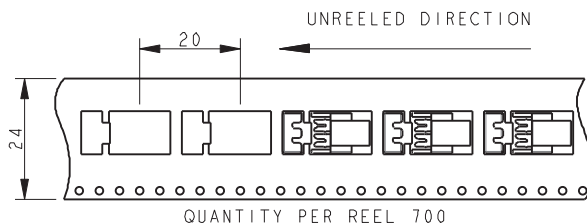

IDC Socket: 24-9159-WTB

3 Position Through Wire Cap

SOCKET WIRED – 3 WAY THROUGH WIRE CAP

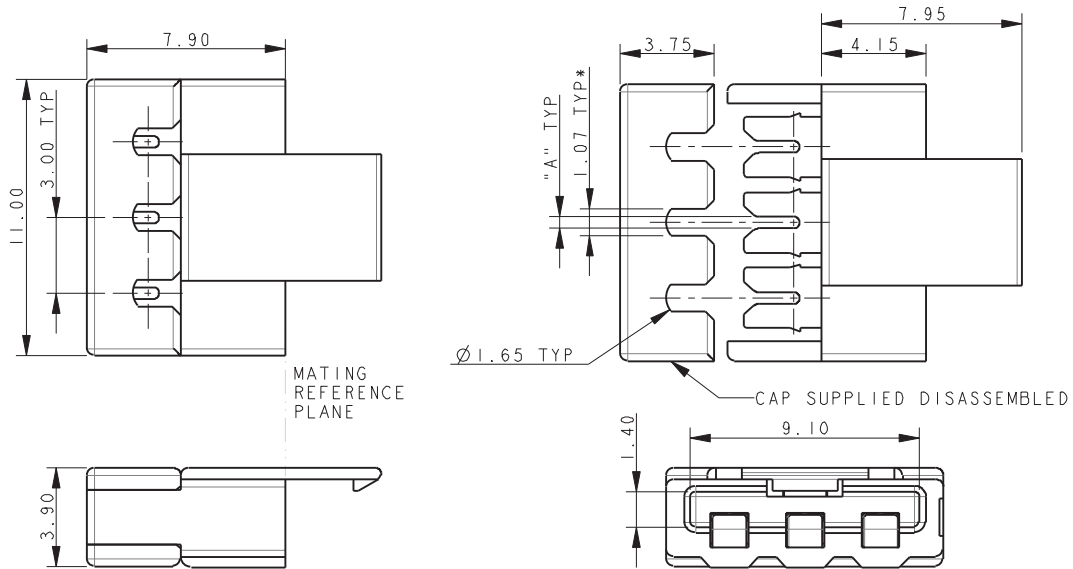

NOTES:

1. FOR MORE INFORMATION REFER TO PRODUCT SPEC 201-01-119. FOR WIRE ASSEMBLY REFER TO APPLICATION NOTES 201-01-123.
2. THROUGH WIRE CAP, FOR TERMINATION OF WIRE IN ANY POSITION.
3. CAP ACTS AS WIRE ASSEMBLY TOOL. WIRE PREFIT TO CAP, NARROW SLOT TO GRIP WIRE, PERMANENT ASSEMBLY.
4. GENERAL TOLERANCE ± 0.20 UNLESS SPECIFIED.
5. INSULATOR MATERIAL: NYLON 46, GLASS FILLED, UL94 V-0. COLOR REFER TO PAGE 50.
6. CONTACT MATERIAL: COPPER ALLOY, PLATING NICKEL BASE ALL OVER, GOLD ON CONTACT, TIN ON IDC.
7. PACKING IN TAPE AND REEL. QTY PER REEL 700, POCKET CONTAINS 1 CONNECTOR AND 1 CAP.
8. WIRE GAUGE OPTIONS, SEE TABLE.
9. ASSEMBLY AIDS, REFER TO PAGE 61.

Wire Gauge	Code (Page 50)	Dimension A	Wire Insulation Diameter
22AWG (Stranded Wire)	122	0.47	1.10 to 1.60
24AWG (Stranded Wire)	132	0.37	1.10 to 1.60

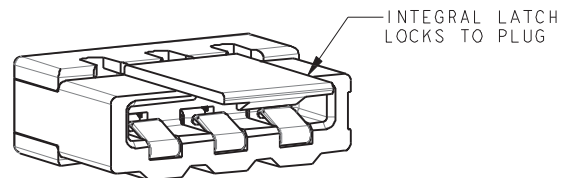
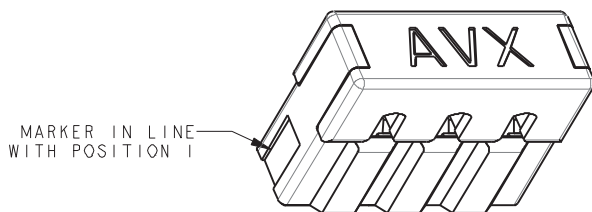

PACKING DETAILS CAP AND CONNECTOR SUPPLIED TOGETHER (2 PARTS)

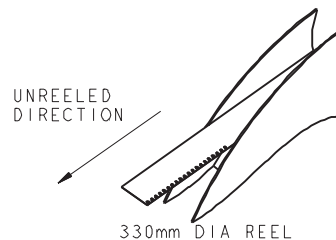
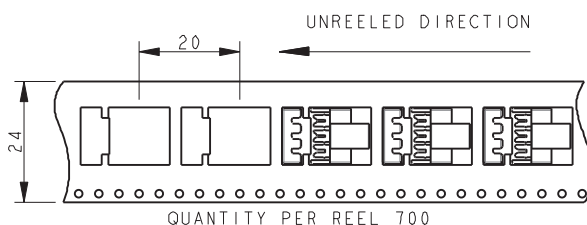

IDC Socket: 24-9159-WTB

4 Position Through Wire Cap

SOCKET WIRED – 4 WAY THROUGH WIRE CAP

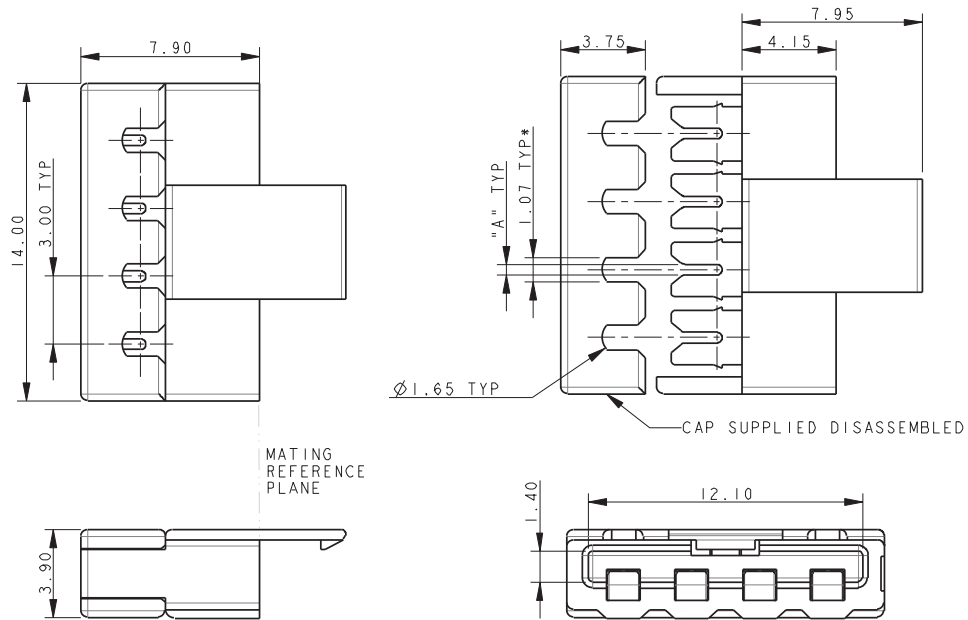

NOTES:

- FOR MORE INFORMATION REFER TO PRODUCT SPEC 201-01-119.
FOR WIRE ASSEMBLY REFER TO APPLICATION NOTES 201-01-123.
- THROUGH WIRE CAP, FOR TERMINATION OF WIRE IN ANY POSITION.
- CAP ACTS AS WIRE ASSEMBLY TOOL. WIRE PREFIT TO CAP, NARROW SLOT TO GRIP WIRE, PERMANENT ASSEMBLY.
- GENERAL TOLERANCE ± 0.20 UNLESS SPECIFIED.
- INSULATOR MATERIAL: NYLON 46, GLASS FILLED, UL94 V-0. COLOR REFER TO PAGE 50.
- CONTACT MATERIAL: COPPER ALLOY, PLATING NICKEL BASE ALL OVER, GOLD ON CONTACT, TIN ON IDC.
- PACKING IN TAPE AND REEL. QTY PER REEL 700, POCKET CONTAINS 1 CONNECTOR AND 1 CAP.
- WIRE GAUGE OPTIONS, SEE TABLE.
- ASSEMBLY AIDS, REFER TO PAGE 61.

Wire Gauge	Code (Page 50)	Dimension A	Wire Insulation Diameter
22AWG (Stranded Wire)	122	0.47	1.10 to 1.60
24AWG (Stranded Wire)	132	0.37	1.10 to 1.60

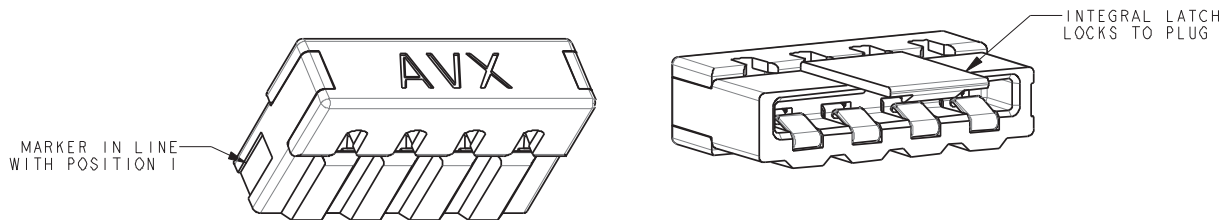

PACKING DETAILS CAP AND CONNECTOR SUPPLIED TOGETHER (2 PARTS)

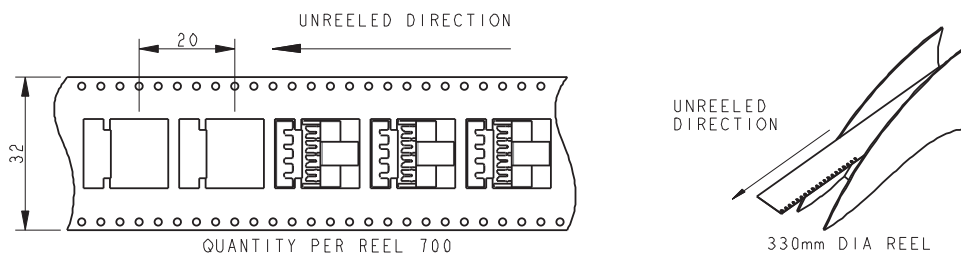

IDC Socket: 24-9159-WTB

5 Position Through Wire Cap

SOCKET WIRED – 5 WAY THROUGH WIRE CAP

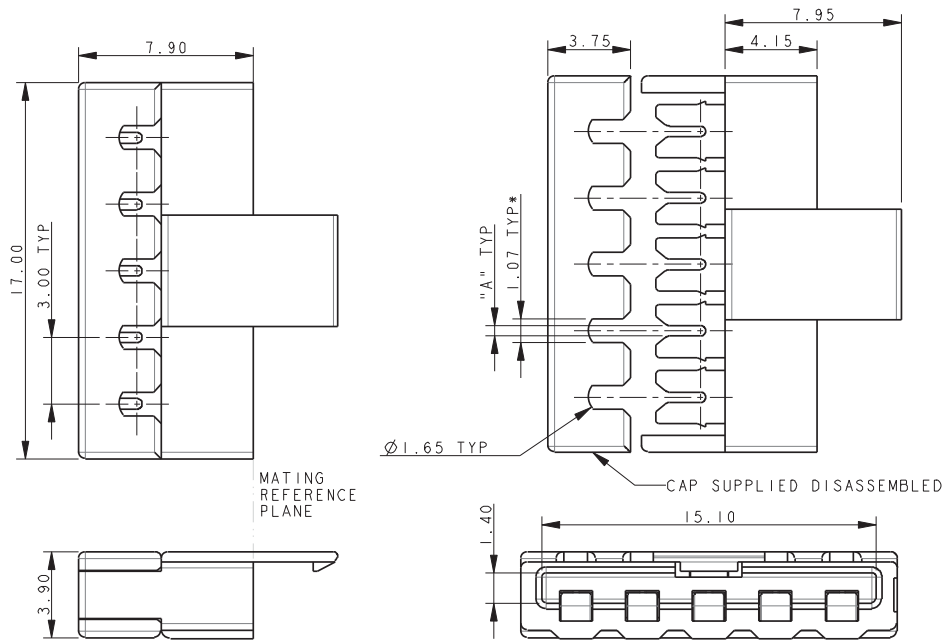

NOTES:

1. FOR MORE INFORMATION REFER TO PRODUCT SPEC 201-01-119.
FOR WIRE ASSEMBLY REFER TO APPLICATION NOTES 201-01-123.
2. THROUGH WIRE CAP, FOR TERMINATION OF WIRE IN ANY POSITION.
3. CAP ACTS AS WIRE ASSEMBLY TOOL. WIRE PREFIT TO CAP, NARROW SLOT TO GRIP WIRE, PERMANENT ASSEMBLY.
4. GENERAL TOLERANCE ± 0.20 UNLESS SPECIFIED.
5. INSULATOR MATERIAL: NYLON 46, GLASS FILLED, UL94 V-0. COLOR REFER TO PAGE 50.
6. CONTACT MATERIAL: COPPER ALLOY, PLATING NICKEL BASE ALL OVER, GOLD ON CONTACT, TIN ON IDC.
7. PACKING IN TAPE AND REEL. QTY PER REEL 700, POCKET CONTAINS 1 CONNECTOR AND 1 CAP.
8. WIRE GAUGE OPTIONS, SEE TABLE.
9. ASSEMBLY AIDS, REFER TO PAGE 61.

Wire Gauge	Code (Page 50)	Dimension A	Wire Insulation Diameter
22AWG (Stranded Wire)	122	0.47	1.10 to 1.60
24AWG (Stranded Wire)	132	0.37	1.10 to 1.60

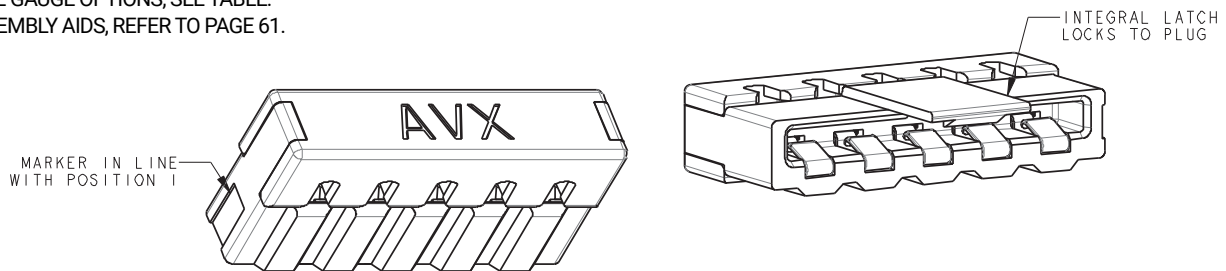

PACKING DETAILS CAP AND CONNECTOR SUPPLIED TOGETHER (2 PARTS)

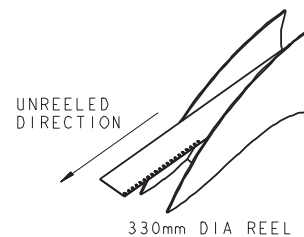
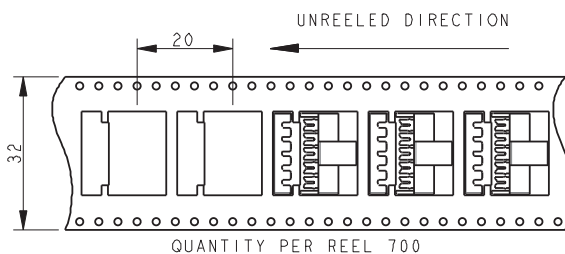

IDC Socket: 24-9159-WTB

6 Position Through Wire Cap

SOCKET WIRED – 6 WAY THROUGH WIRE CAP

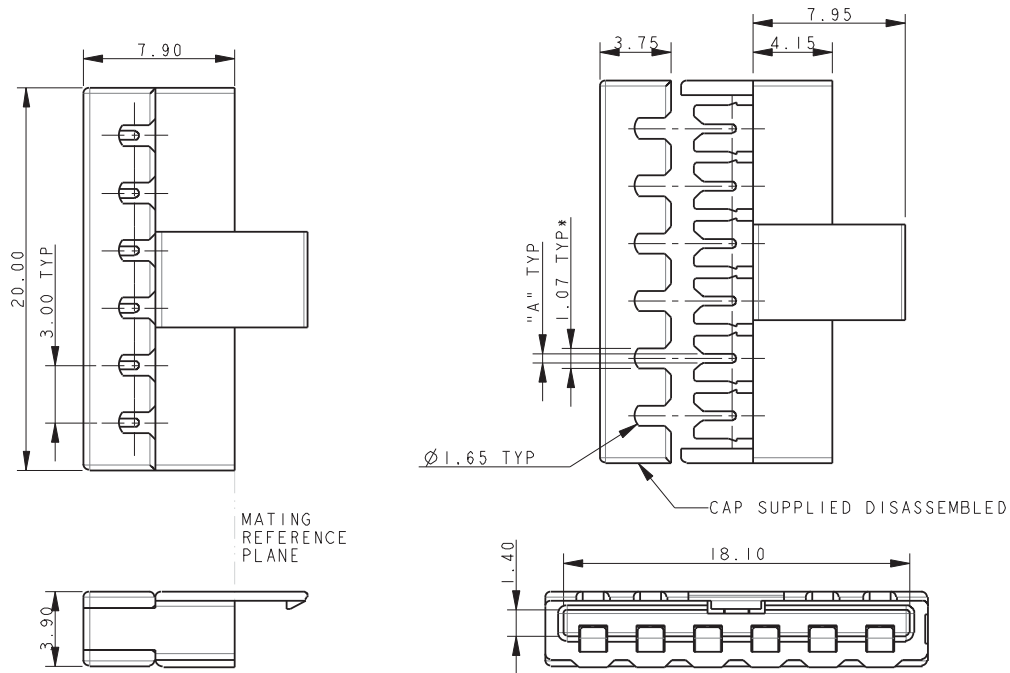

NOTES:

1. FOR MORE INFORMATION REFER TO PRODUCT SPEC 201-01-119.
FOR WIRE ASSEMBLY REFER TO APPLICATION NOTES 201-01-123.
2. THROUGH WIRE CAP, FOR TERMINATION OF WIRE IN ANY POSITION.
3. CAP ACTS AS WIRE ASSEMBLY TOOL. WIRE PREFIT TO CAP, NARROW SLOT TO GRIP WIRE, PERMANENT ASSEMBLY.
4. GENERAL TOLERANCE ± 0.20 UNLESS SPECIFIED.
5. INSULATOR MATERIAL: NYLON 46, GLASS FILLED, UL94 V-0. COLOR REFER TO PAGE 50.
6. CONTACT MATERIAL: COPPER ALLOY, PLATING NICKEL BASE ALL OVER, GOLD ON CONTACT, TIN ON IDC.
7. PACKING IN TAPE AND REEL. QTY PER REEL 700, POCKET CONTAINS 1 CONNECTOR AND 1 CAP.
8. WIRE GAUGE OPTIONS, SEE TABLE.
9. ASSEMBLY AIDS, REFER TO PAGE 61.

Wire Gauge	Code (Page 50)	Dimension A	Wire Insulation Diameter
22AWG (Stranded Wire)	122	0.47	1.10 to 1.60
24AWG (Stranded Wire)	132	0.37	1.10 to 1.60

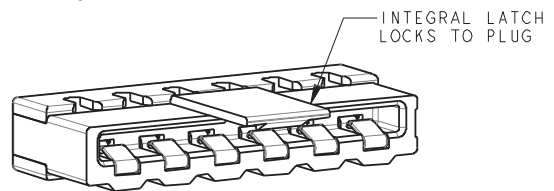
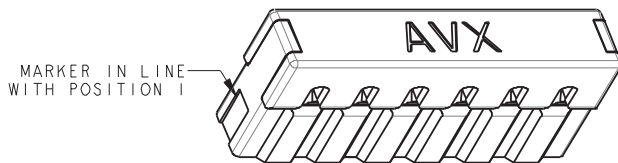

PACKING DETAILS CAP AND CONNECTOR SUPPLIED TOGETHER (2 PARTS)

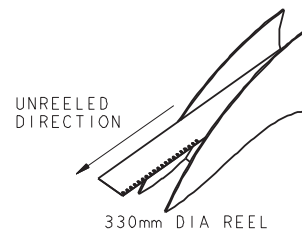
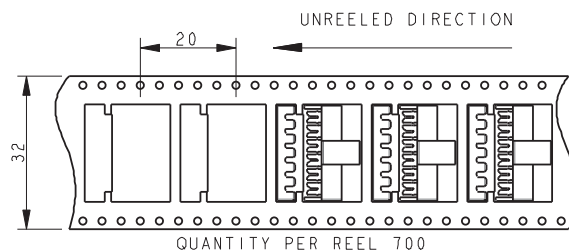

IDC Socket: 24-9159-WTB

2 Position Wire Stop Cap

SOCKET-WIRED – 2 WAY WIRE STOP CAP

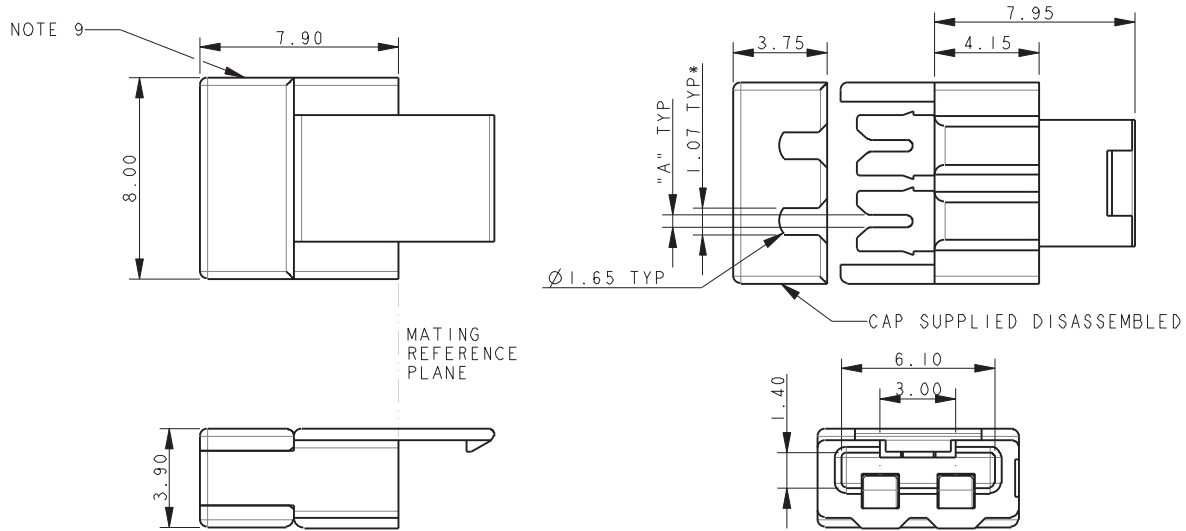

NOTES:

1. FOR MORE INFORMATION REFER TO PRODUCT SPEC 201-01-119.
FOR WIRE ASSEMBLY REFER TO APPLICATION NOTES 201-01-123.
2. WIRE STOP CAP, WITH STOP FACE ON ONE SIDE TO PROTECT END OF WIRE.
3. CAP ACTS AS WIRE ASSEMBLY TOOL. WIRE PREFIT TO CAP, NARROW SLOT TO GRIP WIRE, PERMANENT ASSEMBLY.
4. GENERAL TOLERANCE ± 0.20 UNLESS SPECIFIED.
5. INSULATOR MATERIAL: NYLON 46, GLASS FILLED, UL94 V-0. COLOR REFER TO PAGE 50.
6. CONTACT MATERIAL: COPPER ALLOY, PLATING NICKEL BASE ALL OVER, GOLD ON CONTACT, TIN ON IDC.
7. PACKING IN TAPE AND REEL. QTY PER REEL 700, POCKET CONTAINS 1 CONNECTOR AND 1 CAP.
8. WIRE GAUGE OPTIONS, SEE TABLE.
9. SHOWN WITH WIRE ENTRY FROM UNDERSIDE, CAP CAN BE ASSEMBLED FOR EITHER TOP OR UNDERSIDE WIRE ENTRY.
10. ASSEMBLY AIDS, REFER TO PAGE 61.

Wire Gauge	Code (Page 50)	Dimension A	Wire Insulation Diameter
22AWG (Stranded Wire)	122	0.47	1.10 to 1.60
24AWG (Stranded Wire)	132	0.37	1.10 to 1.60

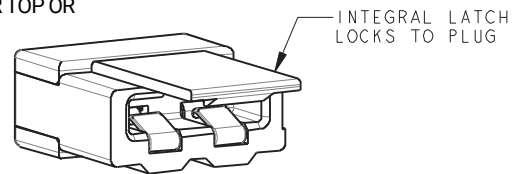
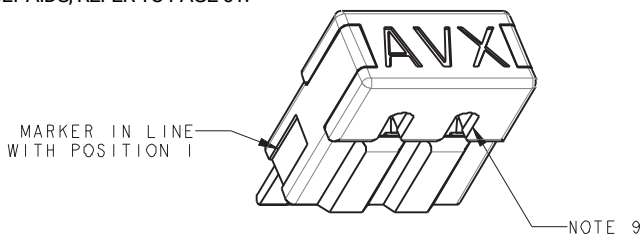

PACKING DETAILS CAP AND CONNECTOR SUPPLIED TOGETHER (2 PARTS)

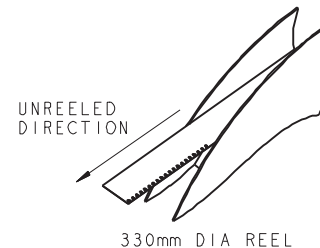
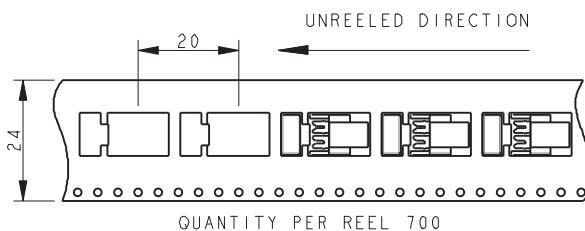

IDC Socket: 24-9159 WTB

3 Position Wire Stop Cap

SOCKET-WIRED – 3 WAY WIRE STOP CAP

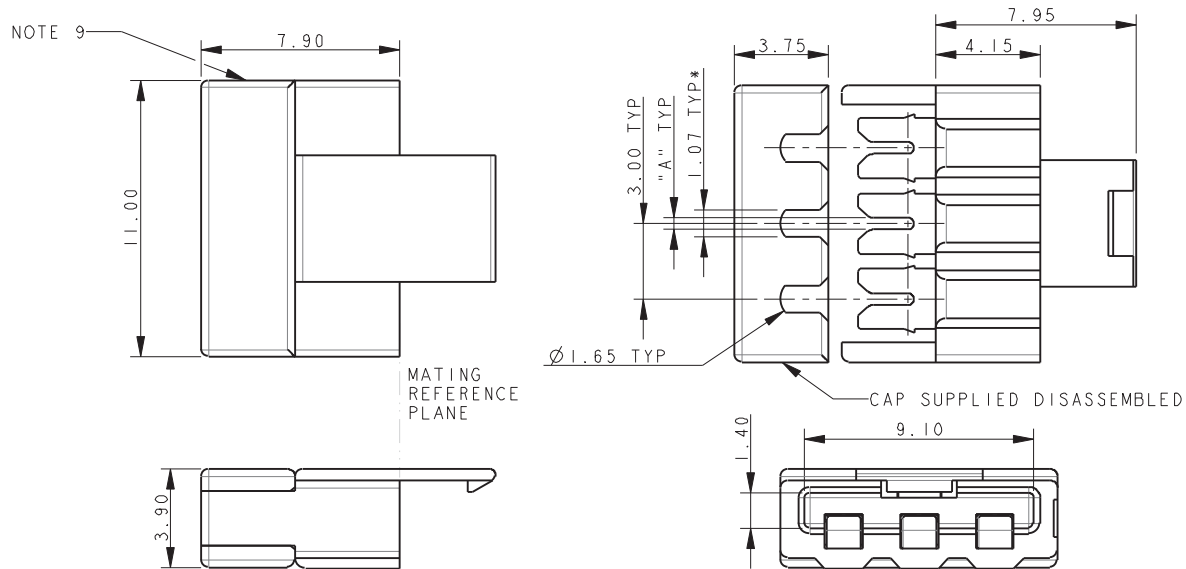

NOTES:

1. FOR MORE INFORMATION REFER TO PRODUCT SPEC 201-01-119.
FOR WIRE ASSEMBLY REFER TO APPLICATION NOTES 201-01-123.
2. WIRE STOP CAP, WITH STOP FACE ON ONE SIDE TO PROTECT END OF WIRE.
3. CAP ACTS AS WIRE ASSEMBLY TOOL. WIRE PREFIT TO CAP, NARROW SLOT TO GRIP WIRE, PERMANENT ASSEMBLY.
4. GENERAL TOLERANCE ± 0.20 UNLESS SPECIFIED.
5. INSULATOR MATERIAL: NYLON 46, GLASS FILLED, UL94 V-0. COLOR REFER TO PAGE 50.
6. CONTACT MATERIAL: COPPER ALLOY, PLATING NICKEL BASE ALL OVER, GOLD ON CONTACT, TIN ON IDC.
7. PACKING IN TAPE AND REEL. QTY PER REEL 700, POCKET CONTAINS 1 CONNECTOR AND 1 CAP.
8. WIRE GAUGE OPTIONS, SEE TABLE.
9. SHOWN WITH WIRE ENTRY FROM UNDERSIDE, CAP CAN BE ASSEMBLED FOR EITHER TOP OR UNDERSIDE WIRE ENTRY.
10. ASSEMBLY AIDS, REFER TO PAGE 61.

Wire Gauge	Code (Page 50)	Dimension A	Wire Insulation Diameter
22AWG (Stranded Wire)	122	0.47	1.10 to 1.60
24AWG (Stranded Wire)	132	0.37	1.10 to 1.60

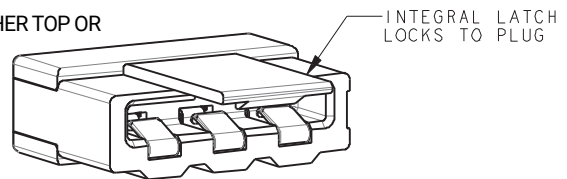
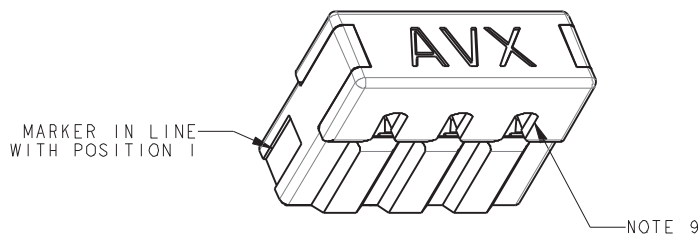

PACKING DETAILS CAP AND CONNECTOR SUPPLIED TOGETHER (2 PARTS)

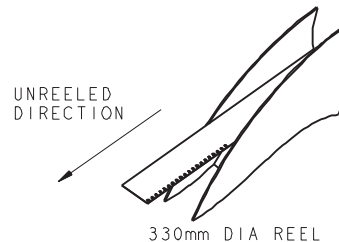
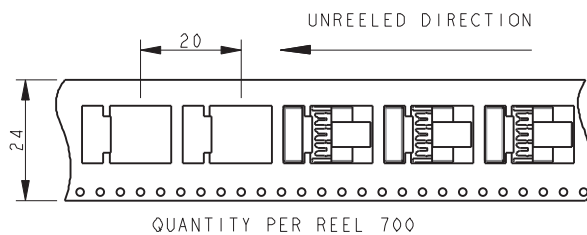

IDC Socket: 24-9159-WTB

4 Position Wire Stop Cap

SOCKET-WIRED – 4 WAY WIRE STOP CAP

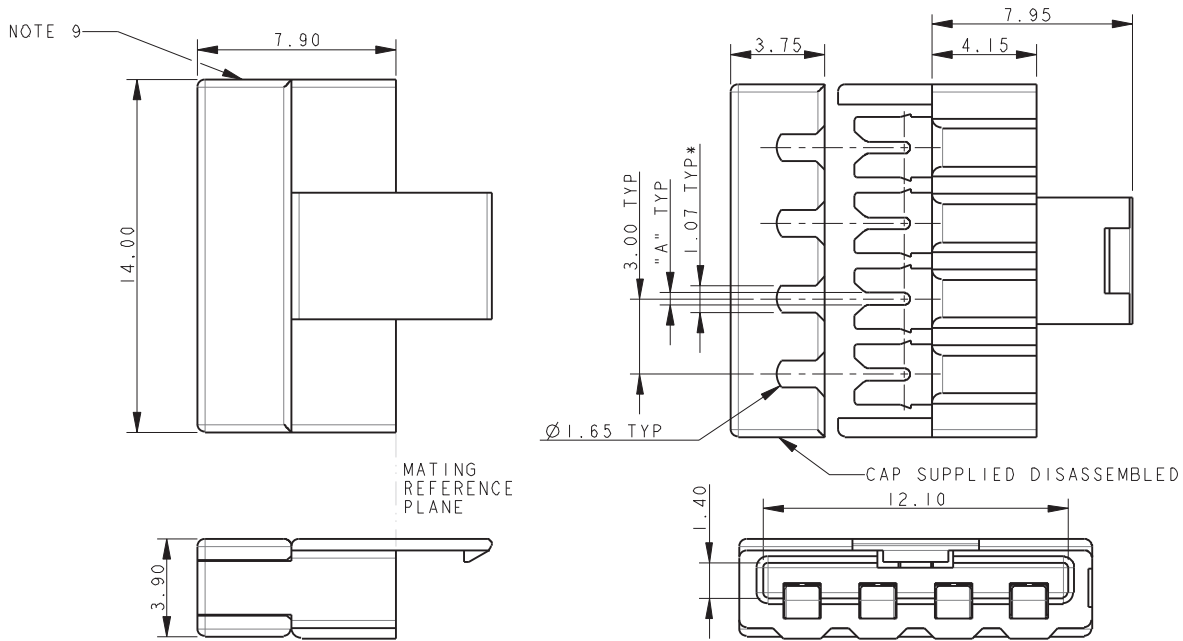

NOTES:

1. FOR MORE INFORMATION REFER TO PRODUCT SPEC 201-01-119. FOR WIRE ASSEMBLY REFER TO APPLICATION NOTES 201-01-123.
2. WIRE STOP CAP, WITH STOP FACE ON ONE SIDE TO PROTECT END OF WIRE.
3. CAP ACTS AS WIRE ASSEMBLY TOOL. WIRE PREFIT TO CAP, NARROW SLOT TO GRIP WIRE, PERMANENT ASSEMBLY.
4. GENERAL TOLERANCE ± 0.20 UNLESS SPECIFIED.
5. INSULATOR MATERIAL: NYLON 46, GLASS FILLED, UL94 V-0. COLOR REFER TO PAGE 50.
6. CONTACT MATERIAL: COPPER ALLOY, PLATING NICKEL BASE ALL OVER, GOLD ON CONTACT, TIN ON IDC.
7. PACKING IN TAPE AND REEL. QTY PER REEL 700, POCKET CONTAINS 1 CONNECTOR AND 1 CAP.
8. WIRE GAUGE OPTIONS, SEE TABLE.
9. SHOWN WITH WIRE ENTRY FROM UNDERSIDE, CAP CAN BE ASSEMBLED FOR EITHER TOP OR UNDERSIDE WIRE ENTRY.
10. ASSEMBLY AIDS, REFER TO PAGE 61.

Wire Gauge	Code (Page 50)	Dimension A	Wire Insulation Diameter
22AWG (Stranded Wire)	122	0.47	1.10 to 1.60
24AWG (Stranded Wire)	132	0.37	1.10 to 1.60

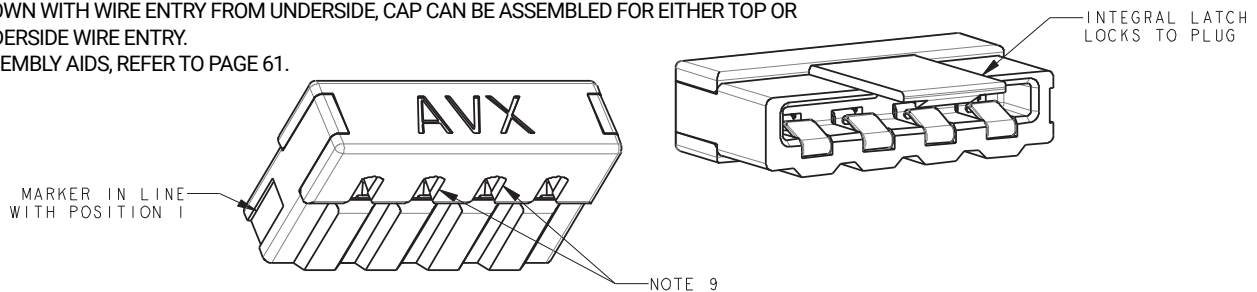

PACKING DETAILS CAP AND CONNECTOR SUPPLIED TOGETHER (2 PARTS)

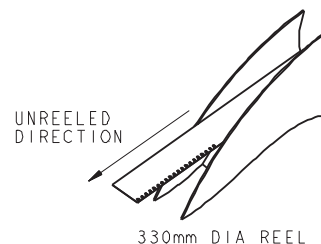
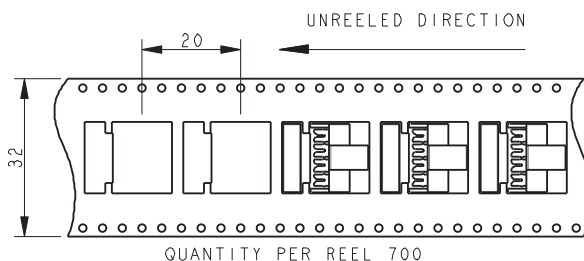

IDC Socket: 24-9159-WTB

5 Position Wire Stop Cap

SOCKET-WIRED – 5 WAY WIRE STOP CAP

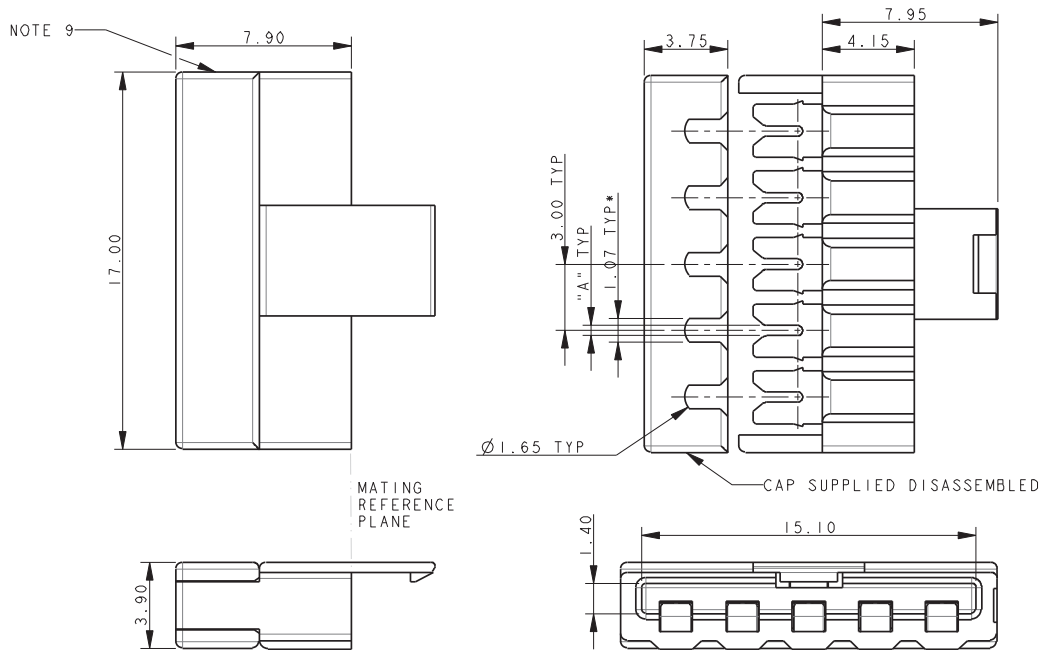

NOTES:

1. FOR MORE INFORMATION REFER TO PRODUCT SPEC 201-01-119.
FOR WIRE ASSEMBLY REFER TO APPLICATION NOTES 201-01-123.
2. WIRE STOP CAP, WITH STOP FACE ON ONE SIDE TO PROTECT END OF WIRE.
3. CAP ACTS AS WIRE ASSEMBLY TOOL. WIRE PREFIT TO CAP, NARROW SLOT TO GRIP WIRE, PERMANENT ASSEMBLY.
4. GENERAL TOLERANCE ± 0.20 UNLESS SPECIFIED.
5. INSULATOR MATERIAL: NYLON 46, GLASS FILLED, UL94 V-0. COLOR REFER TO PAGE 50.
6. CONTACT MATERIAL: COPPER ALLOY, PLATING NICKEL BASE ALL OVER, GOLD ON CONTACT, TIN ON IDC.
7. PACKING IN TAPE AND REEL. QTY PER REEL 700, POCKET CONTAINS 1 CONNECTOR AND 1 CAP.
8. WIRE GAUGE OPTIONS, SEE TABLE.
9. SHOWN WITH WIRE ENTRY FROM UNDERSIDE, CAP CAN BE ASSEMBLED FOR EITHER TOP OR UNDERSIDE WIRE ENTRY.
10. ASSEMBLY AIDS, REFER TO PAGE 61.

Wire Gauge	Code (Page 50)	Dimension A	Wire Insulation Diameter
22AWG (Stranded Wire)	122	0.47	1.10 to 1.60
24AWG (Stranded Wire)	132	0.37	1.10 to 1.60

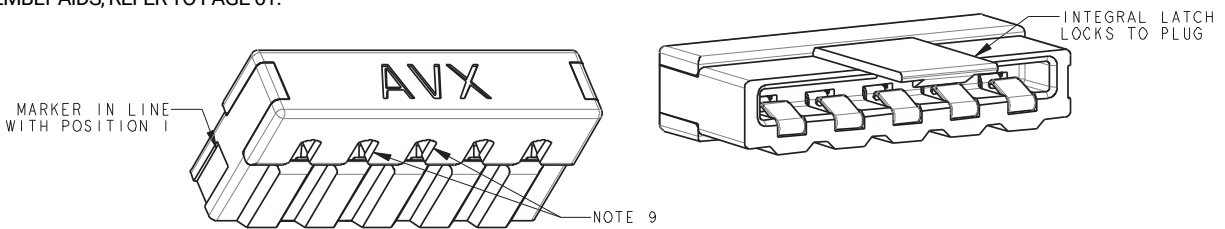

PACKING DETAILS CAP AND CONNECTOR SUPPLIED TOGETHER (2 PARTS)

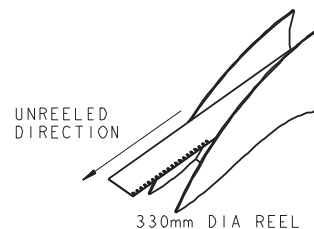
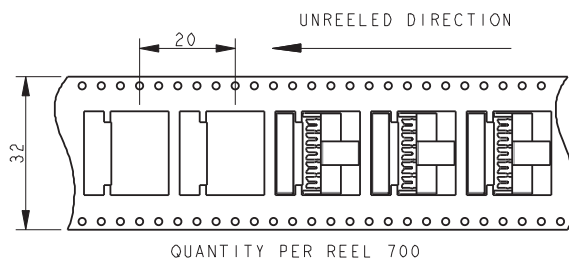

IDC Socket: 24-9159-WTB

6 Position Wire Stop Cap

SOCKET-WIRED – 6 WAY WIRE STOP CAP

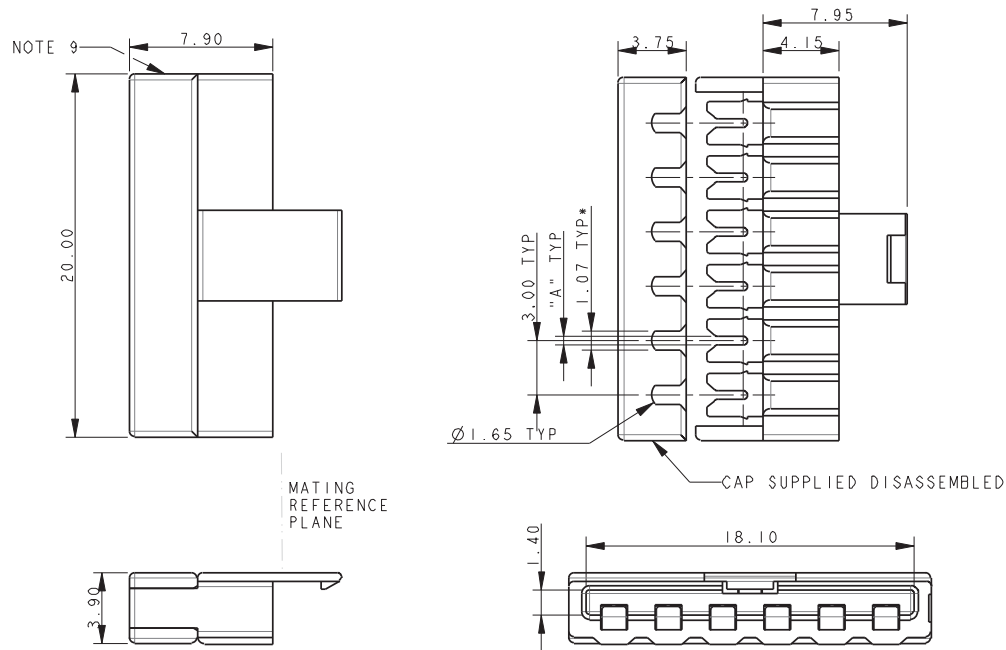

NOTES:

1. FOR MORE INFORMATION REFER TO PRODUCT SPEC 201-01-119. FOR WIRE ASSEMBLY REFER TO APPLICATION NOTES 201-01-123.
2. WIRE STOP CAP, WITH STOP FACE ON ONE SIDE TO PROTECT END OF WIRE.
3. CAP ACTS AS WIRE ASSEMBLY TOOL. WIRE PREFIT TO CAP, NARROW SLOT TO GRIP WIRE, PERMANENT ASSEMBLY.
4. GENERAL TOLERANCE ± 0.20 UNLESS SPECIFIED.
5. INSULATOR MATERIAL: NYLON 46, GLASS FILLED, UL94 V-0. COLOR REFER TO PAGE 50.
6. CONTACT MATERIAL: COPPER ALLOY, PLATING NICKEL BASE ALL OVER, GOLD ON CONTACT, TIN ON IDC.
7. PACKING IN TAPE AND REEL. QTY PER REEL 700, POCKET CONTAINS 1 CONNECTOR AND 1 CAP.
8. WIRE GAUGE OPTIONS, SEE TABLE.
9. SHOWN WITH WIRE ENTRY FROM UNDERSIDE, CAP CAN BE ASSEMBLED FOR EITHER TOP OR UNDERSIDE WIRE ENTRY.
10. ASSEMBLY AIDS, REFER TO PAGE 61.

Wire Gauge	Code (Page 50)	Dimension A	Wire Insulation Diameter
22AWG (Stranded Wire)	122	0.47	1.10 to 1.60
24AWG (Stranded Wire)	132	0.37	1.10 to 1.60

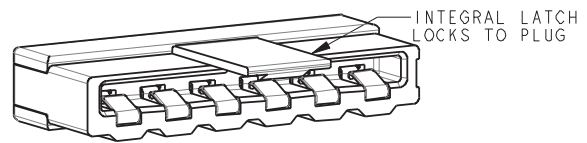
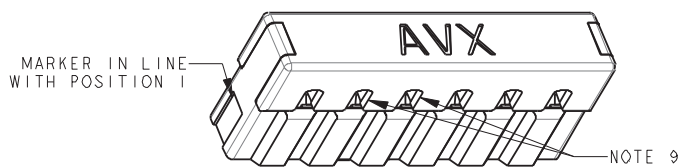

PACKING DETAILS CAP AND CONNECTOR SUPPLIED TOGETHER (2 PARTS)

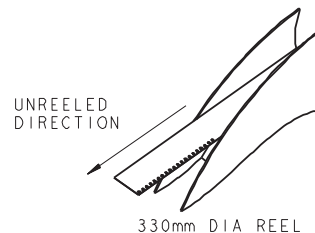
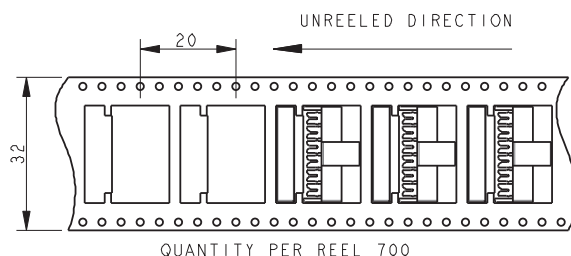

IDC Socket: 24-9159-WTB

Assembly Support Block, Insertion Tool

SOCKET-WIRED – ASSEMBLY SUPPORT BLOCK

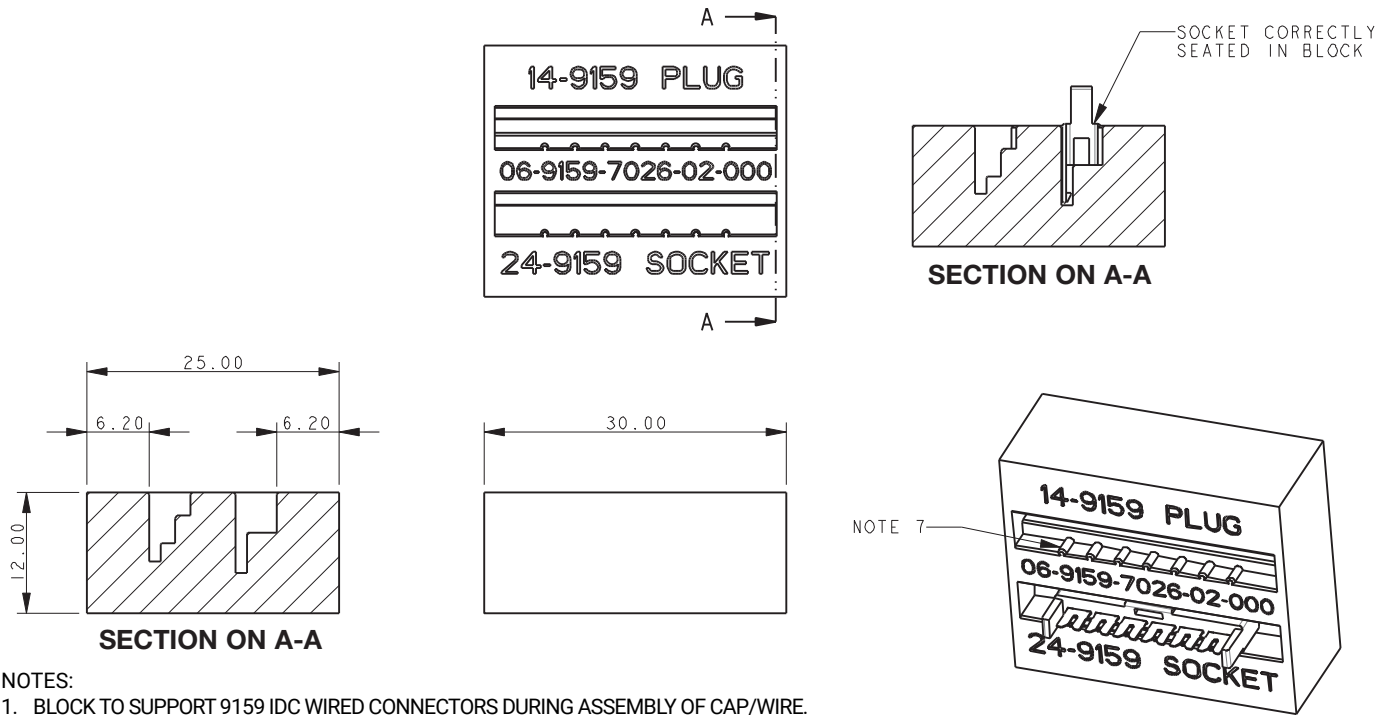

NOTES:

1. BLOCK TO SUPPORT 9159 IDC WIRED CONNECTORS DURING ASSEMBLY OF CAP/WIRE.
2. PART NUMBER 06-9159-7026-01-000, MATERIAL ALUMINUM. PART NUMBER 06-9159-7026-02-000, MATERIAL NYLON 46.
3. CAN BE USED WITH EITHER THE PLUG OR SOCKET CONNECTORS, USE THE CORRECT SLOT AS IDENTIFIED.
4. FOR FULL WIRE ASSEMBLY DETAILS REFER TO APPLICATION NOTES 201-01-123.
5. ONLY A SIMPLE FLAT BOTTOMED TOOL REQUIRED TO PUSH THE CAP DOWN (NOT SUPPLIED.)
6. ALL DIMENSIONS ± 0.20 UNLESS TOLERANCED.
7. 06-9159-7026-02-000 HAS RIBS TO HELP LOCATE CONTACT/INSULATOR SUB-ASSEMBLY.

SOCKET-WIRED – WIRE INSERTION TOOL

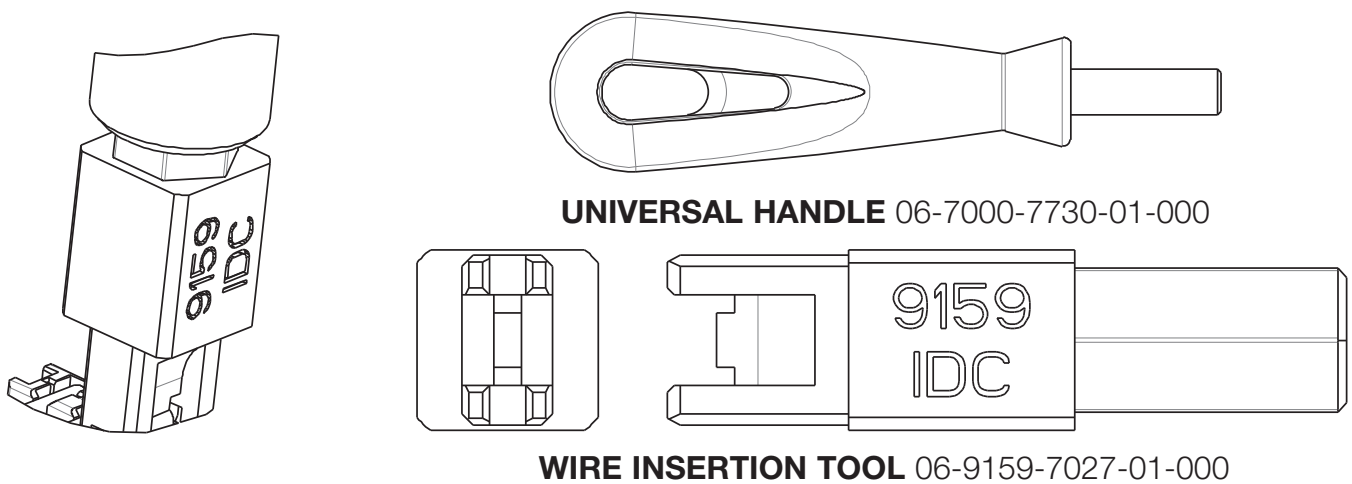

NOTES:

1. TOOL 06-9159-7027-01-000 TO INSERT WIRES INTO CAP.
2. FOR USE WITH UNIVERSAL HANDLE 06-7000-7720-01-000.
3. CAN BE USED WITH BOTH THROUGH WIRE AND WIRE STOP CAPS.
4. REFER TO APPLICATION NOTES 201-01-123 FOR FURTHER DETAILS.

IDC Socket: 24-9159-WTB

Assembly

SOCKET-WIRED – ASSEMBLY

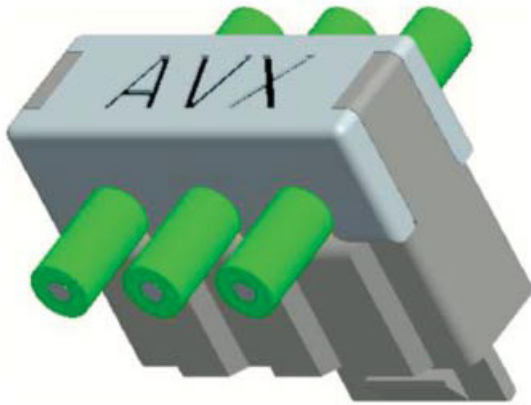

THROUGH WIRE

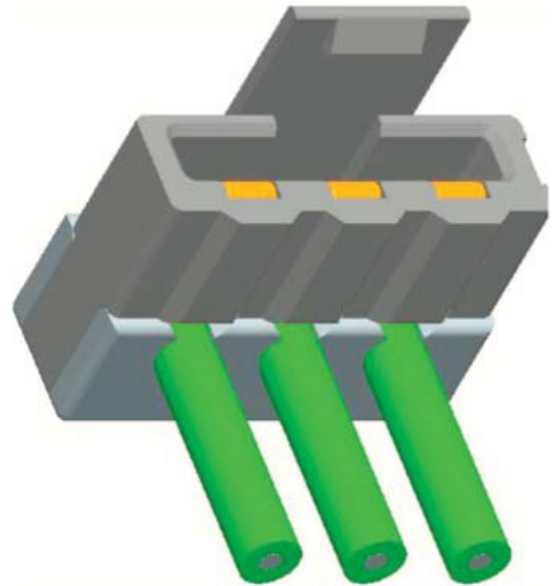

**WIRED STOP
WIRE ENTRY UNDERSIDE**

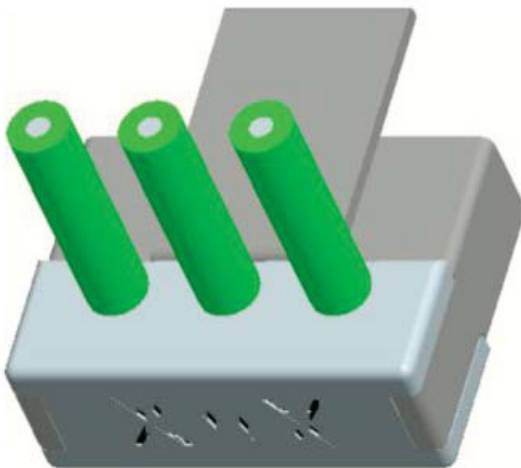

**WIRED STOP
WIRE ENTRY TOP**

Shorting Socket: 58-9159-BTB

General Description



The 9159 series of Board-to-Board interconnect system allows two PCB's to be mated end-to-end creating strips of LED lighting. Designed specifically for the unique Solid State Lighting (SSL) market requiring coplanar (horizontal-to-horizontal) PCB mating with a 5 Amp current rating in the smallest package available. The top loading socket allows complete PCB's to be replaced in the field without having to disassemble the entire strip of boards. The connector has a two part insulator whereby the top of the connector will slide open allowing the plug connector to be pulled out either vertically or at a slight angle. Once the PCB is replaced, the cover is slid back like a Zero Insertion Force (ZIF) connector to the closed position. The PCB layout is identical to the standard horizontal socket to maintain family commonality at the PCB level.

APPLICATIONS

- Coplanar PCB mating in SSL products
- LED linear lighting strips
- Application Notes: refer to 201-01-123

FEATURES AND BENEFITS

- Mates to the standard plug connector: does not require a new connector
- Integral latching mechanism: Provides positive attachment to the plug
- Gold plated BeCu spring contacts: reliability for harsh environments
- Available in white: supports SSL market preferences

ELECTRICAL

- Current Rating: 5 Amps / Contact
- Voltage Rating: 125 VAC

ENVIRONMENTAL

- Operating Temperature: -40°C to +125°C

MECHANICAL

- Insulator Material: Nylon: VL94V0
- Contact Material: BeCu / Phos Bronze
- Plating: Gold / Tin over Nickel
- Durability: 10 Cycles

HOW TO ORDER

58 9159 002 000 006

Certification: UL File #E90723



Shorting Socket: 58-9159-BTB

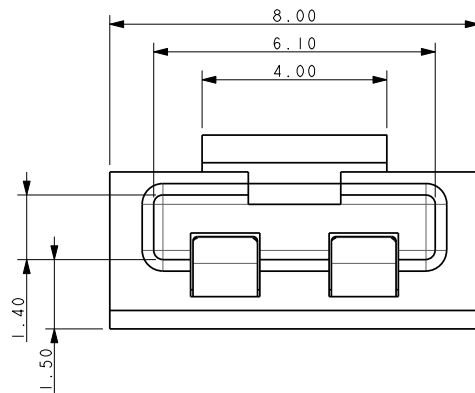
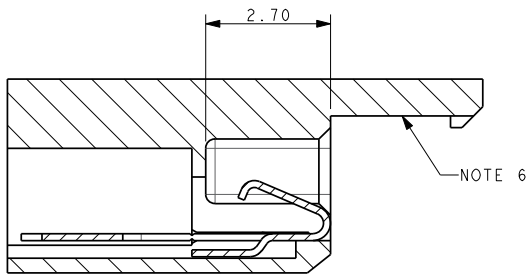
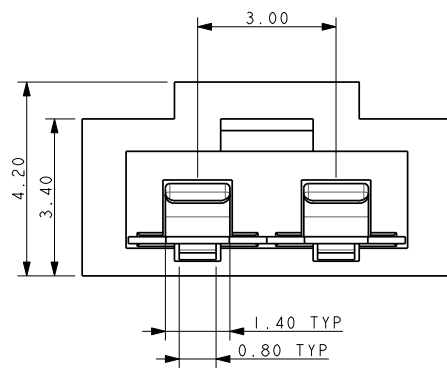
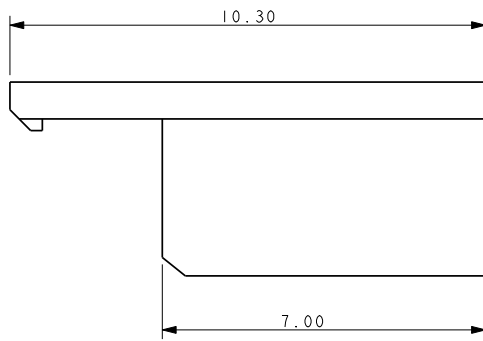
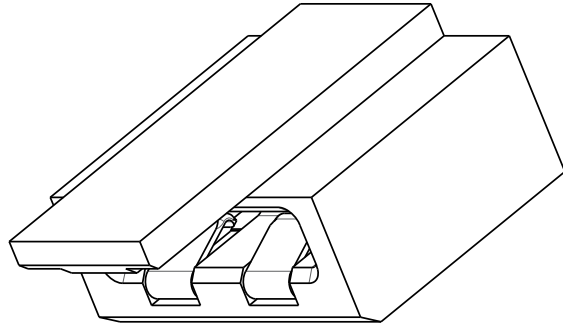

PACKING DETAILS

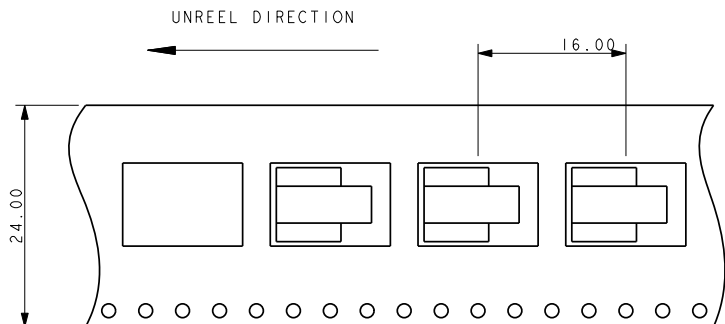
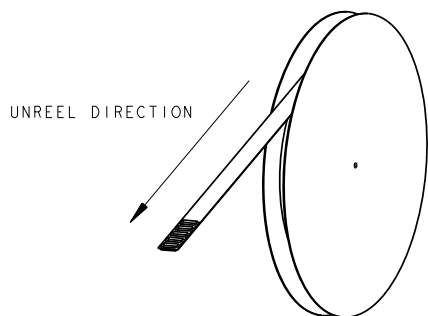

Single 2 Piece Contacts: 70-9159-BTB

General Description

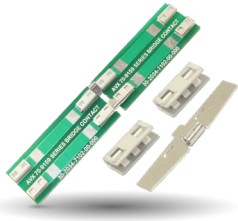

GENERAL DESCRIPTION

Dissecting linear LED lighting from a connector standpoint looks very simple from far away, but up close there is no magical solution. Even though there have been new connectors developed in recent years specifically for this application, the specific requirements in challenging new designs continue to push for something better, different and more cost competitive. KYOCERA AVX has been one of the companies developing new connector systems for this specific application. The 2-Piece 9159 series offers the smallest profile while still supporting full 5 Amp capability. The 1-Piece version offers the best cost advantage for a connectorized solution, yet has limitations in LED pitch densities.

KYOCERA AVX's latest approach is to not even have a connector! LED's run down the center of the board looking to minimize pitch densities to maximize light output. Connectors interrupt this requirement at each Board-to-Board interface. By design and construction, providing a single contact connector is not economical. However, removing the cost of the connector without removing the functionality provides both a technical and cost effective solution. By removing the insulator and allowing contacts to be placed individually, the PCB can be designed with the LED's in the center of the PCB and the contacts on the outer edges. This optimizes the design for functionality and assembly at the best cost possible. More specifically, the contacts are packaged in T&R for automatic placement, absorb significant x and y assembly tolerances and provide a reliable gold-to-gold active contact interface. Application notes are available to outline all of the contact configurations to support both BTB and WTB applications.

APPLICATIONS

- Linear LED strip lighting
- Commercial/Industrial co-planar or extended card applications
- Reference Product Specification 201-01-149

FEATURES AND BENEFITS

- Gold plated horizontal contact system maximizes lateral PCB alignment and mating tolerances with a proven 2-pc connector solution
- Contact height has been minimized to 1.2mm above the PCB to prevent any shadowing effect
- Contacts can be individually spaced to support any voltage rating with a full 5 Amp current rating
- Individual contacts can support BTB and WTB applications

ELECTRICAL

- Current Rating: 5.0 Amps
- Voltage Rating: UL 300V
Based on placement distance

ENVIRONMENTAL

- Operating Temperature:
-40°C to +125°C

MECHANICAL

- Contact Material: Copper Alloy
- Plug Plating: Gold in mating area, tin on tails
- Socket Contact; Gold all over
- Durability 5 Cycles

HOW TO ORDER

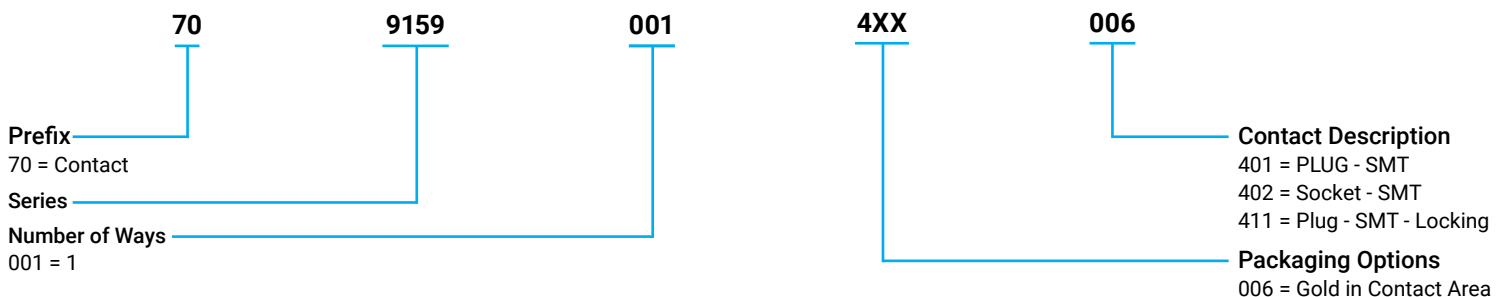

Certification: UL File #E90723

Single 2 Piece Contacts: 70-9159-BTB

401 Plug

70-9159-001-401-006

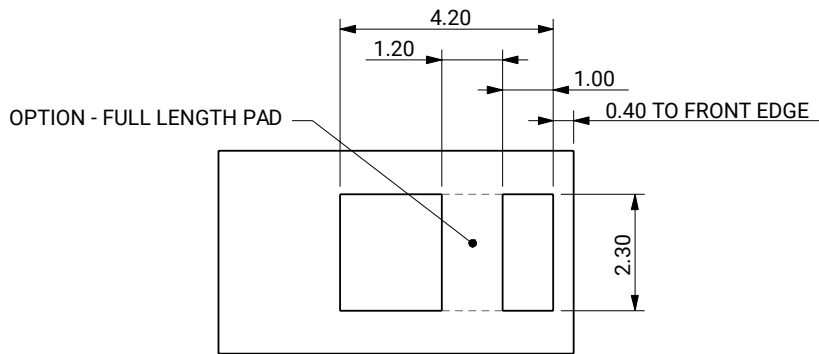
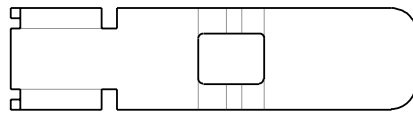
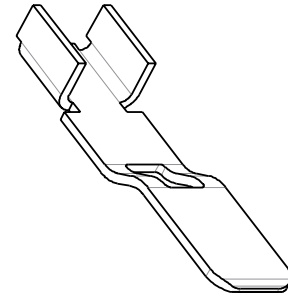
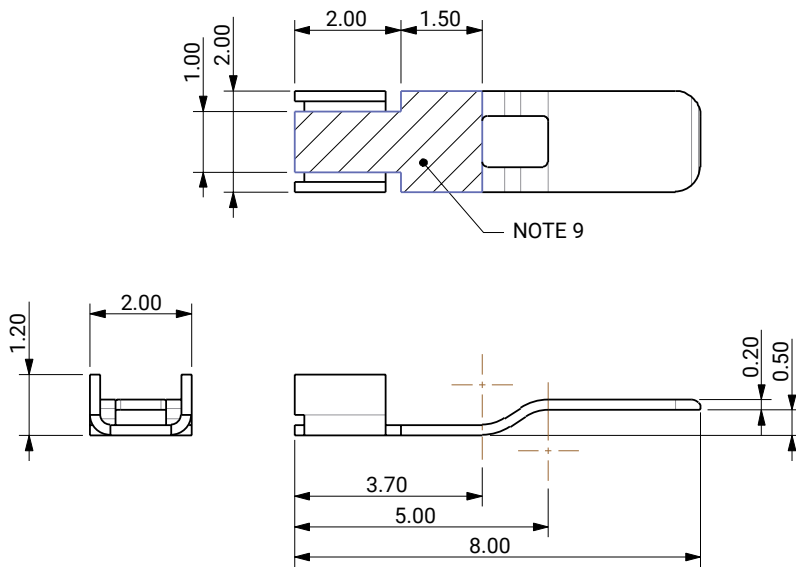

SUGGESTED PCB LAYOUT

NOTES:

1. 9159 SINGLE CONTACT, SMT MOUNT, PLUG CONTACT.
2. TO MATE WITH 70-9159-001-402-006 SOCKET CONTACT, REFER TO PAGE 67.
3. TYPICAL APPLICATIONS SEE PAGES 69 AND 70.
4. FOR FURTHER INFORMATION REFER TO SPECIFICATION 201-01-148 AND APPLICATION NOTES 201-01-149.
5. COPPER ALLOY, NICKEL UNDERCOAT, GOLD IN CONTACT AREA. TIN ON SOLDER TAIL.
6. GENERAL TOLERANCE ± 0.20 UNLESS SPECIFIED.
7. PACKAGING IN TAPE AND REEL, QUANTITY PER REEL 4500.
8. UL REFERENCE E90723 (US AND CANADA).
9. AREA AVAILABLE FOR PICK AND PLACE.

PACKING DETAILS

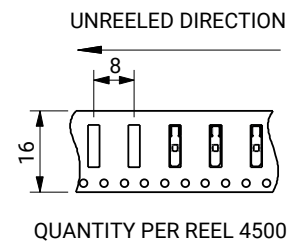
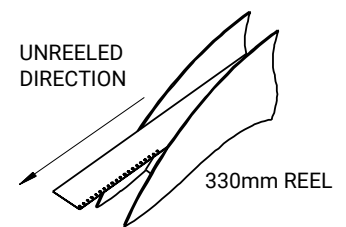

Single 2 Piece Contacts: 70-9159-BTB

402 Socket

70-9159-001-402-006

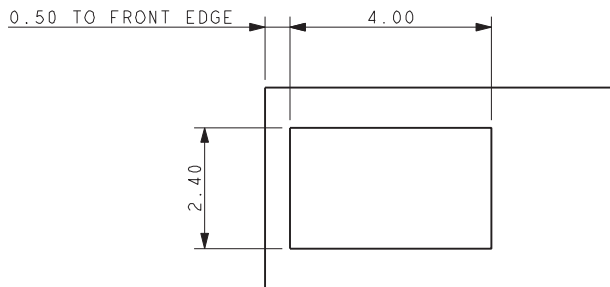
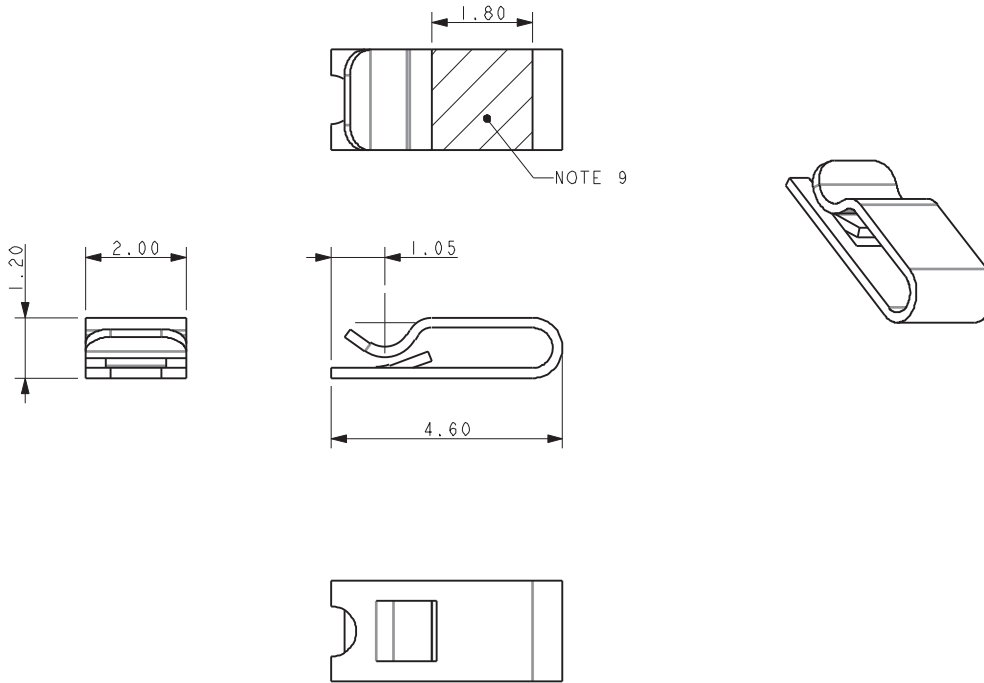

SUGGESTED PCB LAYOUT

PACKING DETAILS

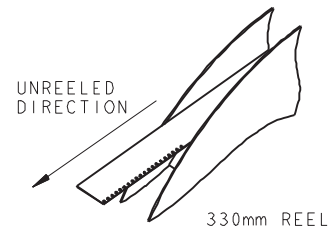

330mm REEL

UNREELED DIRECTION

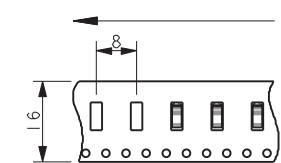

QUANTITY PER REEL 4500

NOTES:

1. 9159 SINGLE CONTACT, SMT MOUNT, SOCKET CONTACT.
2. TO MATE WITH 70-9159-001-401-006 PLUG CONTACT, REFER TO PAGE 66 AND LOCKING PLUG CONTACT 70-9159-001-411-006 PAGE 68.
3. TYPICAL APPLICATIONS SEE PAGES 69 AND 70.
4. FOR FURTHER INFORMATION REFER TO SPECIFICATION 201-01-148 AND APPLICATION NOTES 201-01-149.
5. COPPER ALLOY, NICKEL UNDERCOAT, GOLD PLATED.
6. GENERAL TOLERANCE ± 0.20 UNLESS SPECIFIED.
7. PACKAGING IN TAPE AND REEL, QUANTITY PER REEL 4500.
8. UL REFERENCE E90723 (US AND CANADA).
9. AREA AVAILABLE FOR PICK AND PLACE.

Single 2 Piece Contacts: 70-9159-BTB

411 Locking Plug Contact

70-9159-001-411-006 LOCKING PLUG CONTACT

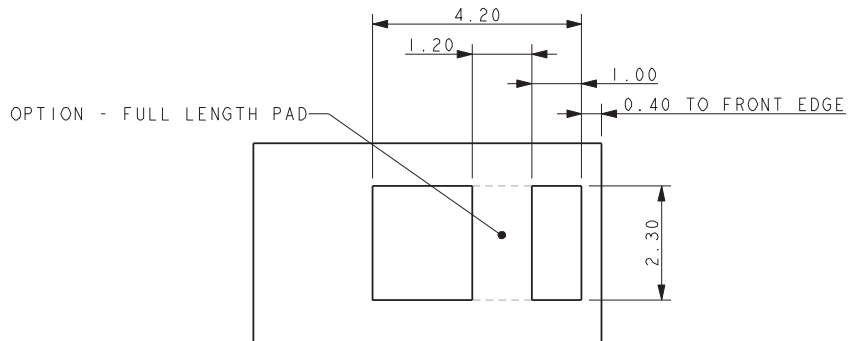
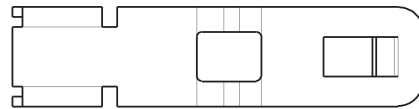
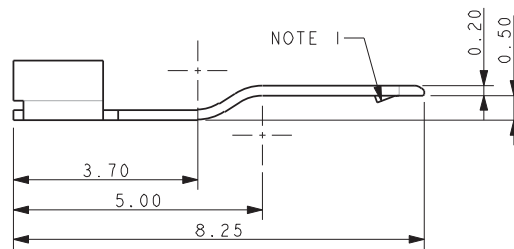
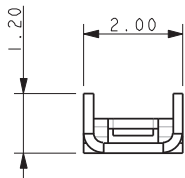
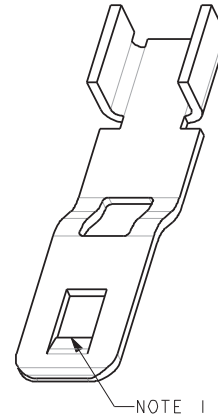
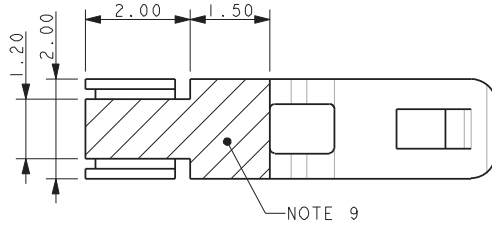

SUGGESTED PCB LAYOUT

PACKING DETAILS

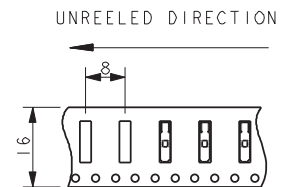
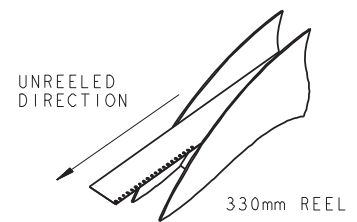

QUANTITY PER REEL 4500

NOTES:

1. 9159 SINGLE CONTACT, SMT MOUNT, PLUG CONTACT. LOCKING FEATURE WILL ASSIST IN MAINTAINING THE POSITION.
2. TO MATE WITH 70-9159-001-402-006 SOCKET CONTACT, REFER TO PAGE 67.
3. TYPICAL APPLICATIONS SEE PAGES 69 AND 70.
4. FOR FURTHER INFORMATION REFER TO SPECIFICATION 201-01-148 AND APPLICATION NOTES 201-01-149.
5. COPPER ALLOY, NICKEL UNDERCOAT, GOLD IN CONTACT AREA. TIN ON SOLDER TAIL.
6. GENERAL TOLERANCE ± 0.20 UNLESS SPECIFIED.
7. PACKAGING IN TAPE AND REEL, QUANTITY PER REEL 4500.
8. UL REFERENCE E90723 (US AND CANADA).
9. AREA AVAILABLE FOR PICK AND PLACE.

Single 2 Piece Contacts: 70-9159-BTB

Contact Solder Tolerance

70-9159-001-4XX-006 – CONTACT SOLDER TOLERANCE

STANDARD CONTACT

70-9159-001-401-006 PLUS 70-9159-001-402-006

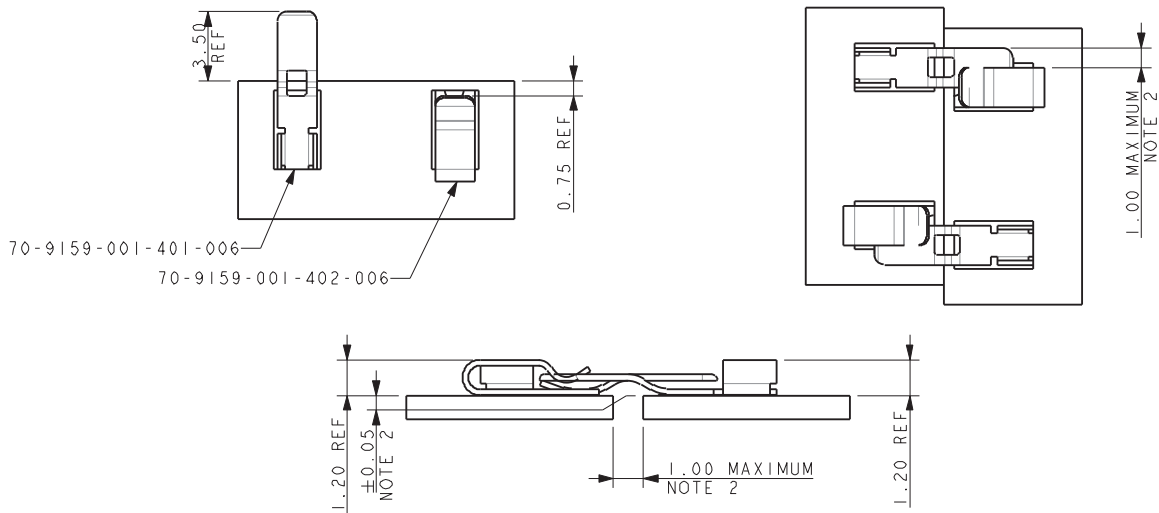

NOTES:

1. SIMPLE BOARD TO BOARD ASSEMBLY.
2. CONTACTS (70-9159-001-401-006) WILL COPE WITH A GAP BETWEEN BOARDS UP TO 1.00MM AND/OR A SIDWAYS MISALIGNMENT OF UP TO 1.00MM WITHOUT LOSS OF PERFORMANCE. VERTICAL MISALIGNMENT MUST HOWEVER BE KEPT TO WITHIN ± 0.05 .

LOCKING CONTACT

70-9159-001-411-006 PLUS 70-9159-001-402-006

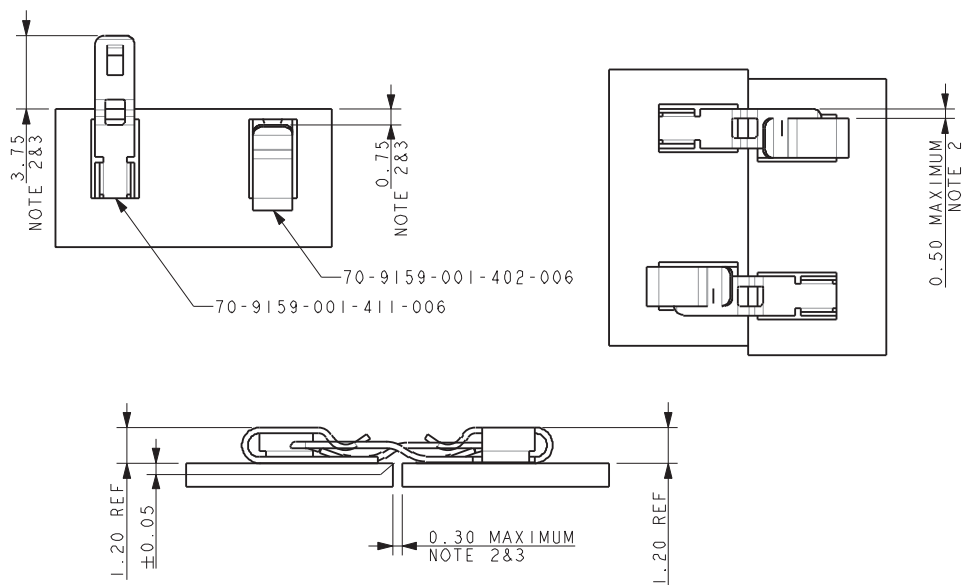

NOTES:

1. LOCKING BOARD TO BOARD ASSEMBLY.
2. CONTACT LOCKING (70-9159-001-411-006) WILL COPE WITH A GAP BETWEEN BOARDS UP TO 0.30MM WITH THE CONTACTS SOLDERED IN POSITIONS SHOWN THE SIDWAYS MISALIGNMENT CAN BE UP TO 0.50MM WITHOUT LOSS OF PERFORMANCE. VERTICAL MISALIGNMENT MUST HOWEVER BE KEPT TO WITHIN ± 0.05 .
3. IF FOR EXAMPLE THE CONTACT PORTIONS ARE CHANGED TO 3.60MM AND 0.90MM RESPECTIVELY.

Single 2 Piece Contacts: 70-9159-BTB

Board to Board Assembly

70-9159-001-40X-006
BOARD TO BOARD ASSEMBLY

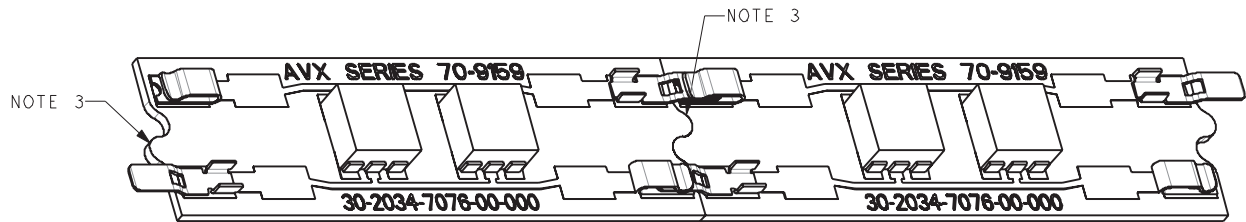
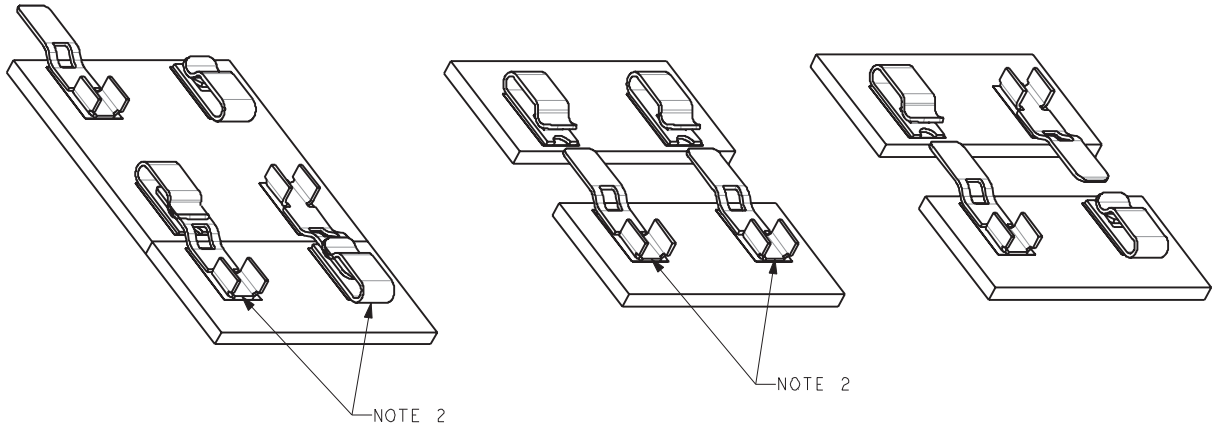

NOTES:

1. SIMPLE BOARD TO BOARD LINK.
2. ALL MATING COMBINATIONS PERMISSIBLE. FOR EXAMPLE BY USING ONE PLUG AND ONE SOCKET CONTACT THE BOARD ENDS ARE REVEALABLE.
3. FEATURES CAN BE ADDED TO BOARD ENDS TO RESIST SIDEWAYS MOVEMENT.

Single 2 Piece Contacts: 70-9159-BTB

Simple Compact Wired Plug Assemblies

70-9159-001-40X-006

SIMPLE COMPACT WIRED PLUG ASSEMBLIES

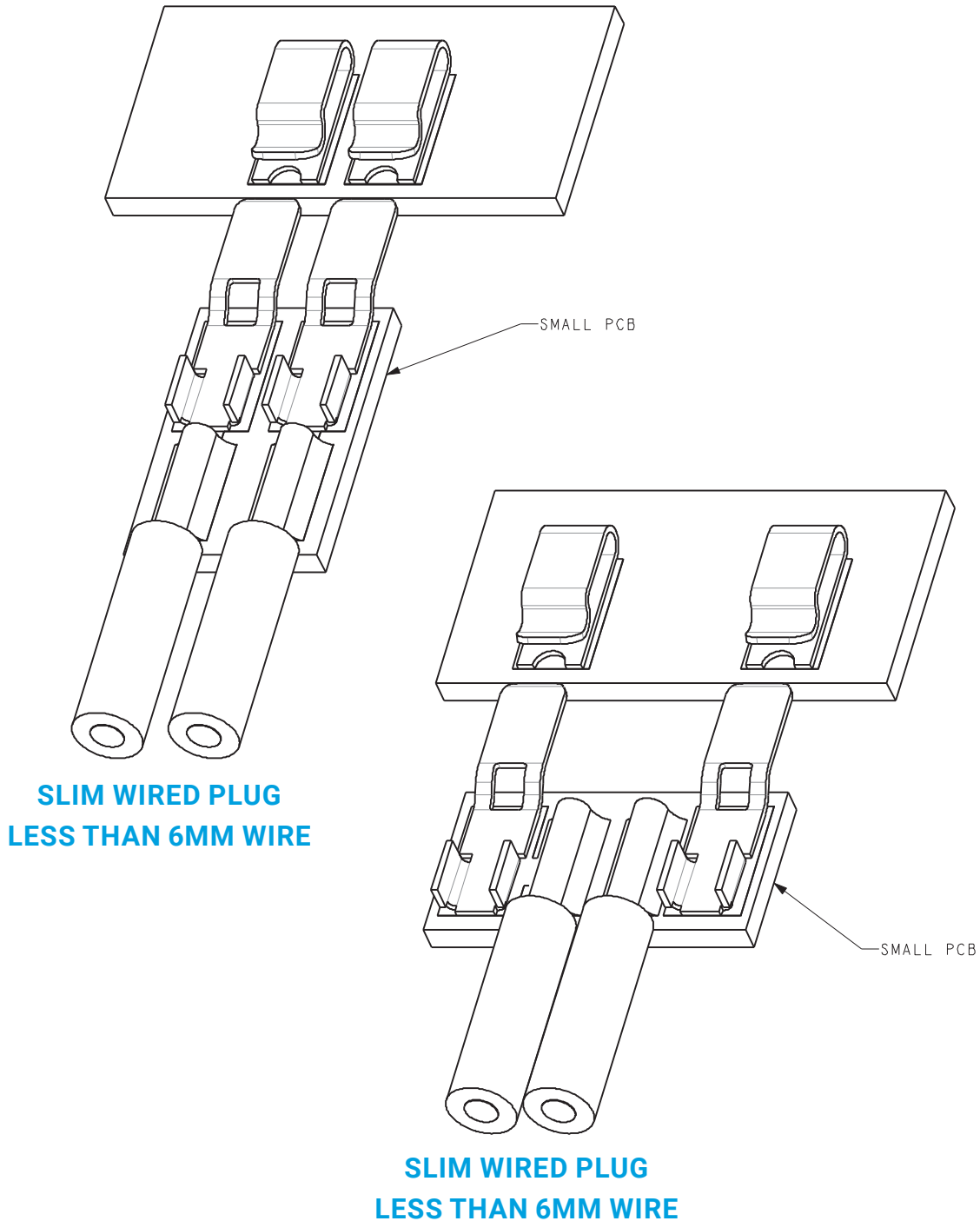

NOTES:

1. SIMPLE BUILT UP ASSEMBLY
2. CONTACTS CAN BE USED WITH A SUITABLE PCB DESIGN FOR CUSTOMER BUILT SMALL CABLE ASSEMBLIES.
3. TWO WAY PLUG CONNECTIONS SHOWN BUT ANY COMBINATION POSSIBLE.

Standard Card Edge: 00-9159-BTB

General Description



The 9159 series of Board-to-Board interconnect system allows two PCB's to be mated end-to-end creating strips of LED lighting. Designed specifically for the unique Solid State Lighting (SSL) market requiring coplanar (horizontal-to-horizontal) PCB mating. The 1-Piece Card Edge connector was developed to provide a reliable, low cost and simple means of connecting multiple PCB's together. The single stamped contact has dual contact beams to guarantee a high contact force on standard 1.6mm PCB's. These connectors are available in 2 through 5 positions and are on 2.0mm pitch centers to provide a 3 amp continuous rating.

APPLICATIONS

- Coplanar PCB mating in SSL products
- LED linear lighting strips

FEATURES AND BENEFITS

- Dual contacts provide positive contact force for enhanced reliability
- Mates with standard 1.6 ± 0.15 mm PCB on 2.0mm pad pitch
- 3 amp current rating for high current applications
- Available in white: supports SSL market preferences

ELECTRICAL

- Current Rating: 3 Amps / Contact
- Voltage Rating: 300 VAC

ENVIRONMENTAL

- Operating Temperature: -40°C to +125°C

MECHANICAL

- Insulator Material: Nylon 46: UL94HB
- Contact Material: Phosphor Bronze
- Plating: Tin over Nickel
- Durability: 5 Cycles

HOW TO ORDER

00
Prefix

9159
Series

00X
Number of Ways

Code	No of Ways	Details
002	2	Page 73
003	3	Page 74
004	4	Page 75
005	5	Page 76

0
Single Part PCB Strip Connector

01
PCB Thickness
01 = 1.60 ± 0.15

9
Color Options
9 = UL

1
Packaging Options
1 = Bag (std)

X
Plating Option
6 = Pure Tin all over
1 = Gold Flash

Certification: UL File #E90723



Standard Card Edge: 00-9159-BTB

2 Position

2 WAY SINGLE PART PCB STRIP CONNECTOR

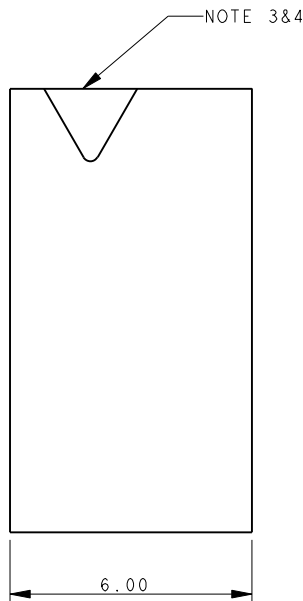
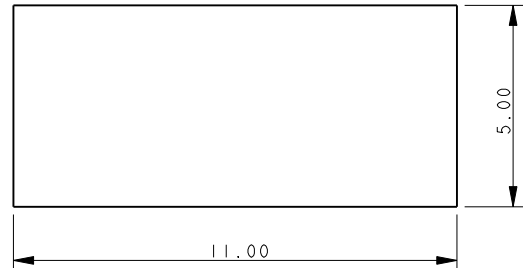
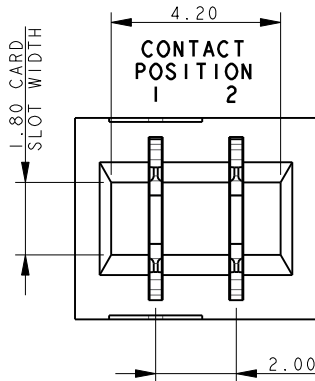

NOTES:

1. FOR MORE INFORMATION REFER TO PRODUCT SPEC 201-01-118.
2. DIMENSIONS ARE REFERENCE DIMENSIONS UNLESS TOLERANCED.
3. ARROW TO INDICATE CONTACT POSITION 1.
4. INSULATOR MATERIAL: NYLON 46, UL94 HB, COLOR SEE PAGE 72.
5. CONTACT MATERIAL: COPPER ALLOY, TIN PLATED ALL OVER, OR GOLD FLASH OVER TIN.
6. PCB PAD, TIN PLATED.

2 WAY PCB BOARD LAYOUT

THICKNESS 1.60 ± 0.15

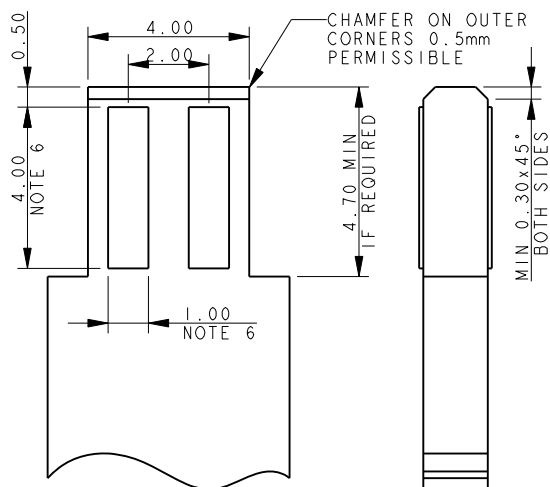

PACKING DETAILS

REEL QTY	750
LEADER	500MM
TRAILER	500MM
REEL PER BOX	TBC

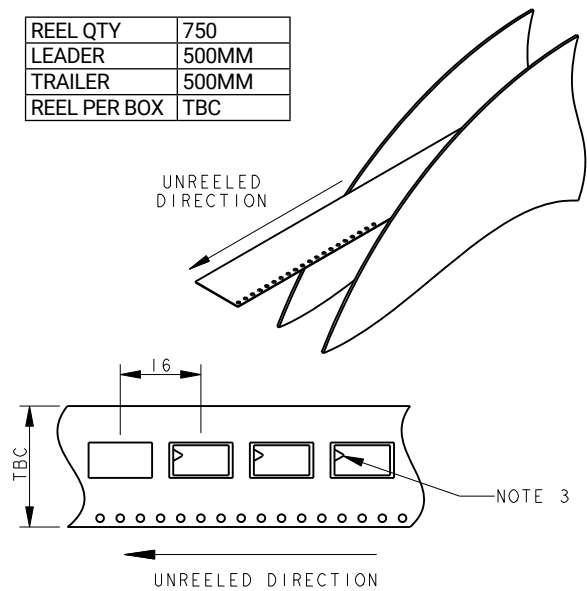

Standard Card Edge: 00-9159-BTB

3 Position

3 WAY SINGLE PART PCB STRIP CONNECTOR

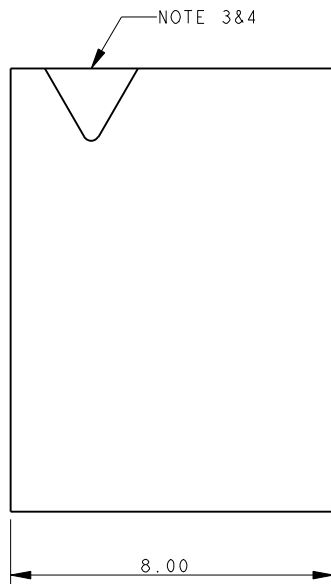
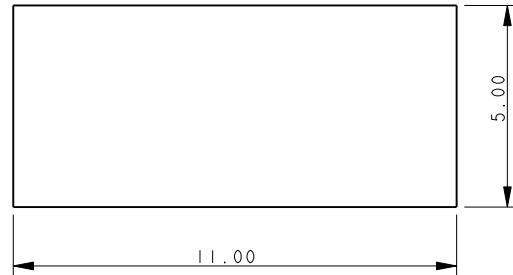
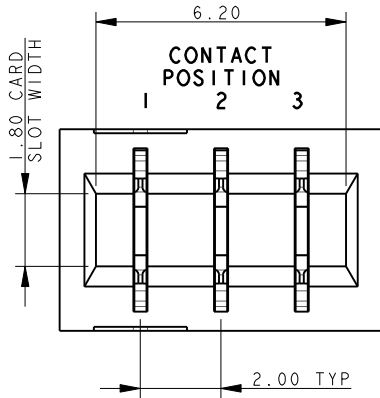

NOTES:

1. FOR MORE INFORMATION REFER TO PRODUCT SPEC 201-01-118.
2. DIMENSIONS ARE REFERENCE DIMENSIONS UNLESS TOLERANCED.
3. ARROW TO INDICATE CONTACT POSITION 1.
4. INSULATOR MATERIAL: NYLON 46, UL94 HB, COLOR SEE PAGE 72.
5. CONTACT MATERIAL: COPPER ALLOY, TIN PLATED ALL OVER, OR GOLD FLASH OVER TIN.
6. PCB PAD, TIN PLATED.

2 WAY PCB BOARD LAYOUT

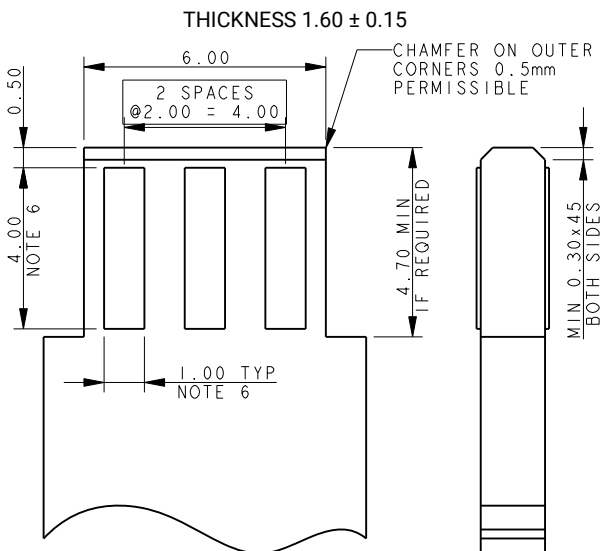

PACKING DETAILS

REEL QTY	750
LEADER	500MM
TRAILER	500MM
REEL PER BOX	TBC

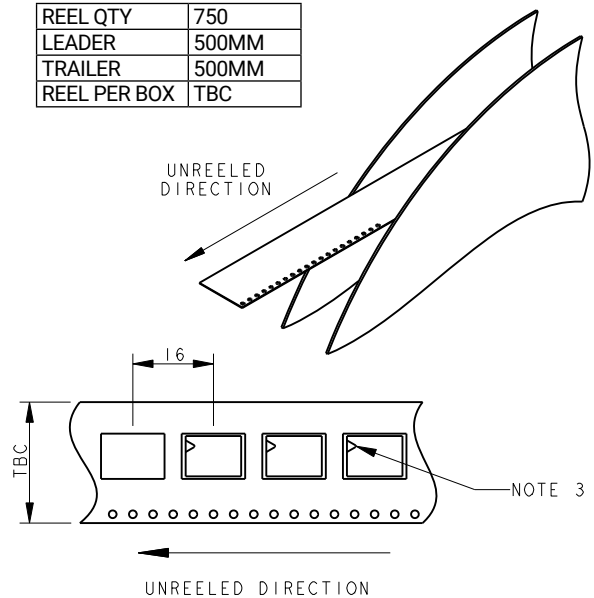

Standard Card Edge: 00-9159-BTB

4 Position

4 WAY SINGLE PART PCB STRIP CONNECTOR

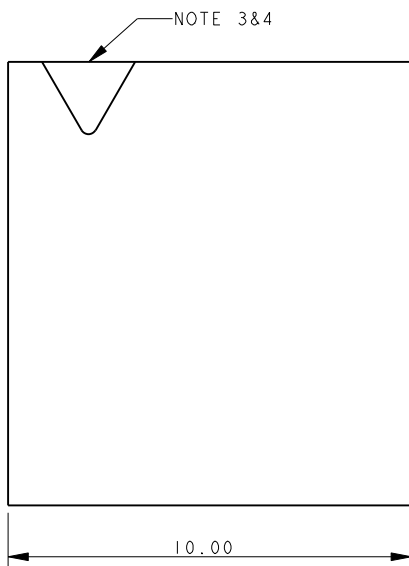
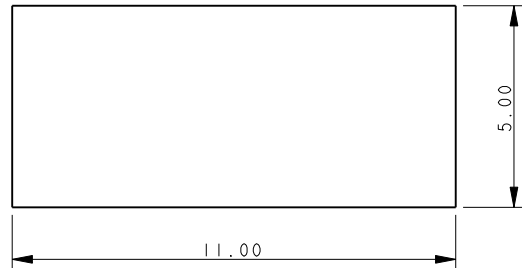
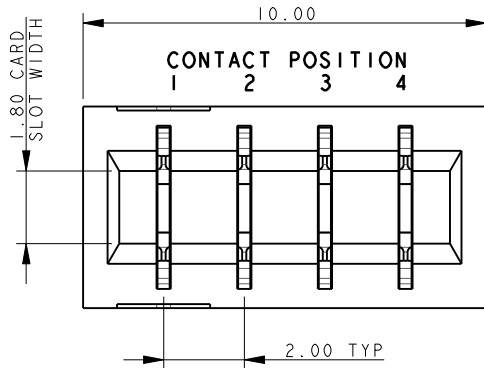

NOTES:

1. FOR MORE INFORMATION REFER TO PRODUCT SPEC 201-01-118.
2. DIMENSIONS ARE REFERENCE DIMENSIONS UNLESS TOLERANCED.
3. ARROW TO INDICATE CONTACT POSITION 1.
4. INSULATOR MATERIAL: NYLON 46, UL94 HB, COLOR SEE PAGE 72.
5. CONTACT MATERIAL: COPPER ALLOY, TIN PLATED ALL OVER, OR GOLD FLASH OVER TIN.
6. PCB PAD, TIN PLATED.

4 WAY PCB BOARD LAYOUT

THICKNESS 1.60 ± 0.15

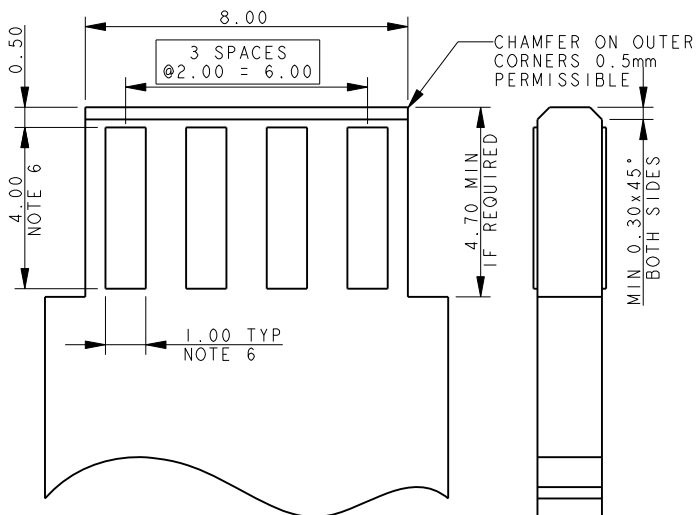

PACKING DETAILS

REEL QTY	750
LEADER	500MM
TRAILER	500MM
REEL PER BOX	TBC

UNREELED DIRECTION

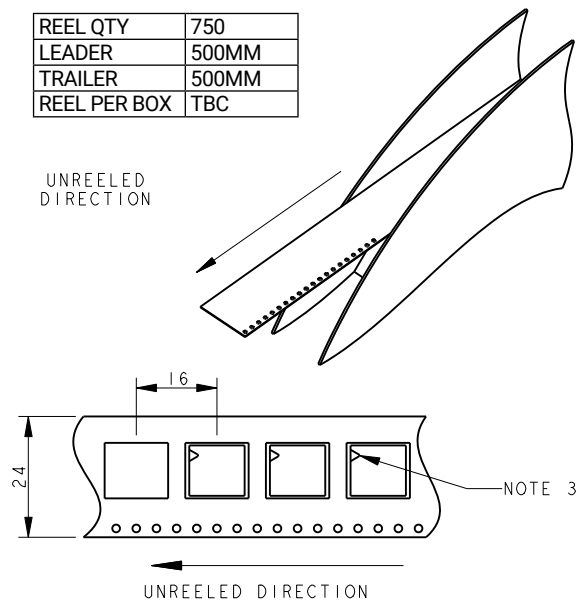

Standard Card Edge: 00-9159-BTB

5 Position

5 WAY SINGLE PART PCB STRIP CONNECTOR

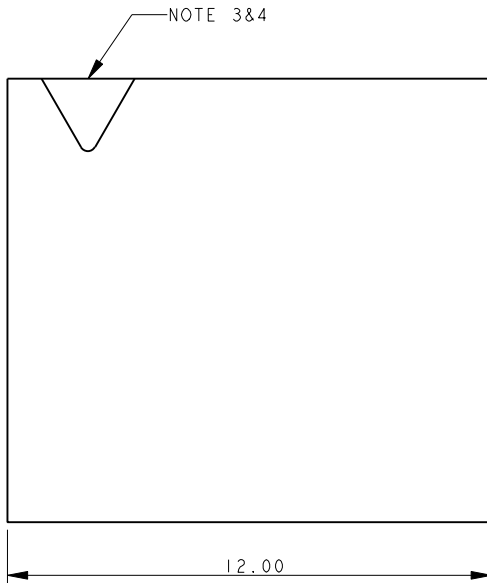
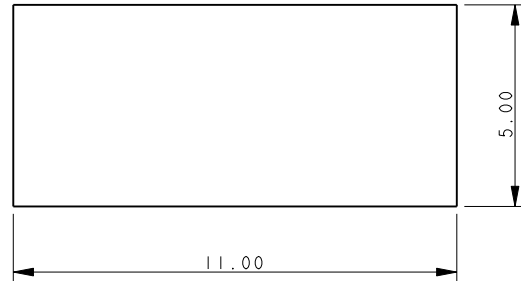
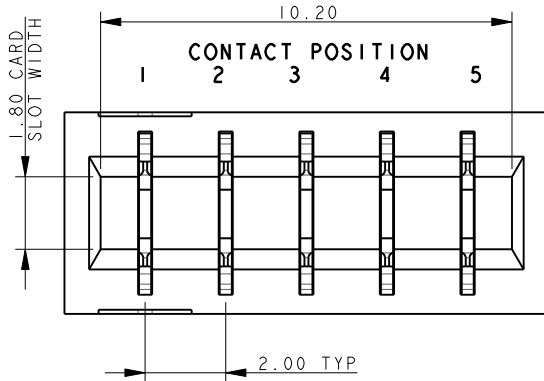

NOTES:

1. FOR MORE INFORMATION REFER TO PRODUCT SPEC 201-01-118.
2. DIMENSIONS ARE REFERENCE DIMENSIONS UNLESS TOLERANCED.
3. ARROW TO INDICATE CONTACT POSITION 1.
4. INSULATOR MATERIAL: NYLON 46, UL94 HB, COLOR SEE PAGE 72.
5. CONTACT MATERIAL: COPPER ALLOY, TIN PLATED ALL OVER, OR GOLD FLASH OVER TIN.
6. PCB PAD, TIN PLATED.

5 WAY PCB BOARD LAYOUT

THICKNESS 1.60 ± 0.15

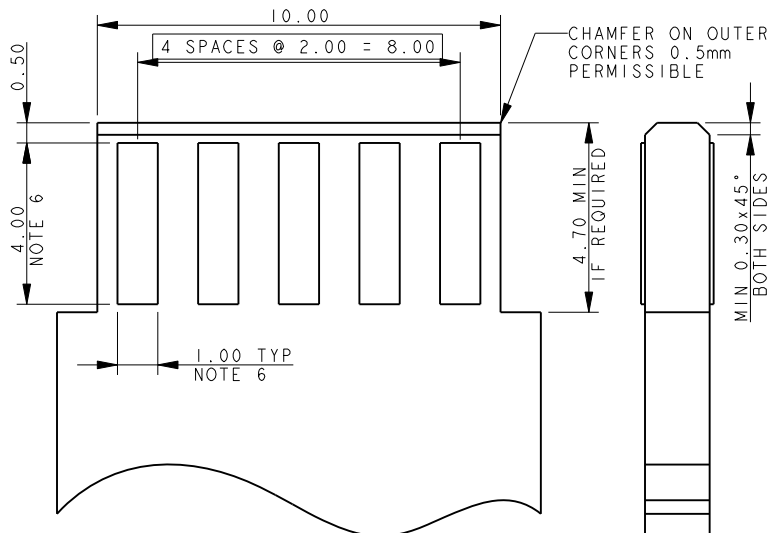

PACKING DETAILS

REEL QTY	750
LEADER	500MM
TRAILER	500MM
REEL PER BOX	TBC

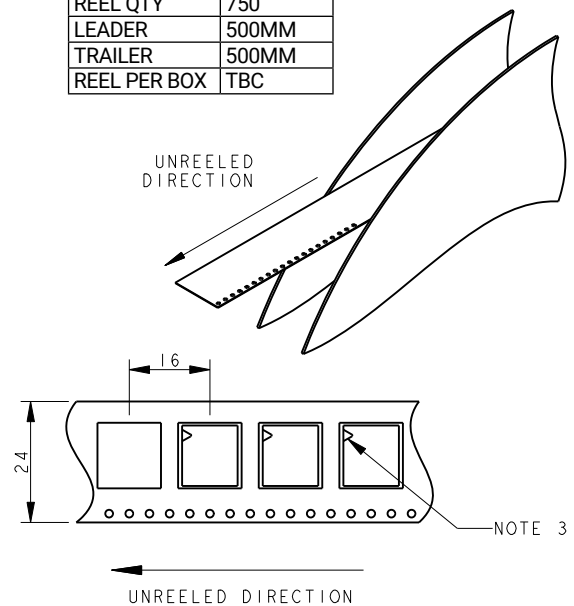

Open Ended Card Edge: 00-9159-BTB

General Description



KYOCERA AVX was challenged with increasing the pin count density as well as minimizing the size of the existing coplanar BTB card edge connector for linear strip lighting. The current product is a 2.0mm with single contacts that straddle the PCB to make electrical connection on both the top and bottom side of the board. By simply changing the contacts to a double sided configuration (separate contacts for both the top and bottom of the PCB), KYOCERA AVX was able to double the pin count in the same 2.0mm pitch with minimal to no impact on the electrical performance of the connector. Reducing the size of the connector required a complete new design as the target was a 4p connector with a total length of 4.0mm. To achieve this, KYOCERA AVX removed the end walls and then added a center support/keying rib to pre-align the PCB during mating. This rib then holds the PCB in the proper functional location.

The new family of connectors is available with contact sizes of 4, 6, 8 and 10 positions, doubling the current products range. The current rating will be 3A for the 4p and 6p, and then drop to 2.5A for the 8p and 10p connector. The connector supports the standard 1.6mm PCB thickness.

This new connector provides the highest density to reliably connect two in-line PCB's together in the most cost effective assembled solution. More importantly, the increased pin count allows for more flexibility in mixing and matching power and signal lines.

APPLICATIONS

- Linear LED strip lighting
- Commercial/Industrial co-planar or extended card applications
- Reference Product Specification 201-01-144

FEATURES AND BENEFITS

- Miniaturized size, achieves 1.0mm in length for each number of contacts (4p =4.0mm)
- Double Ended/Double Sided contacts for increased pin count density on standard 1.6mm thick PCB's
- Central polarizing/location rib assures proper mating and PCB location
- High current capabilities: 3A; 4p/6p and 2.5A; 8p/10p
- Economical high force Tin-to-Tin contact interface

ELECTRICAL

- Current Rating: 3.0 amps 4p/6p and 2.5 amps 8p/10p
- Voltage Rating: 300 VAC

ENVIRONMENTAL

- Operating Temperature: -40°C to +125°C

MECHANICAL

- Insulator Material: Nylon 46: UL94V0
- Contact Material: Phosphor Bronze
- Plating: Tin over Nickel
- Durability: 5 Cycles

HOW TO ORDER

00	9159	00X	0	61	X	1	X																							
Prefix	Series	Number of Ways	Single Part PCB Strip Connector	PCB Thickness 61 = Open Ended PCB Thickness 1.6-±0.10	Color Options	Packaging Options 1 = Bag	Plating Option 6 = Pure Tin all over 1 = Gold Flash																							
		<table border="1" style="margin: auto;"> <thead> <tr> <th>Code</th> <th>No of Ways</th> <th>Details</th> </tr> </thead> <tbody> <tr> <td>004</td> <td>4</td> <td>Page 78</td> </tr> <tr> <td>006</td> <td>6</td> <td>Page 79</td> </tr> <tr> <td>008</td> <td>8</td> <td>Page 80</td> </tr> <tr> <td>010</td> <td>10</td> <td>Page 81</td> </tr> </tbody> </table>	Code	No of Ways	Details	004	4	Page 78	006	6	Page 79	008	8	Page 80	010	10	Page 81		<table border="1" style="margin: auto;"> <thead> <tr> <th>Code</th> <th>Color</th> <th>Application</th> </tr> </thead> <tbody> <tr> <td>8</td> <td>Black</td> <td>Special Order</td> </tr> <tr> <td>9</td> <td>White</td> <td>Standard</td> </tr> </tbody> </table>	Code	Color	Application	8	Black	Special Order	9	White	Standard		
Code	No of Ways	Details																												
004	4	Page 78																												
006	6	Page 79																												
008	8	Page 80																												
010	10	Page 81																												
Code	Color	Application																												
8	Black	Special Order																												
9	White	Standard																												



Certification: UL File #E90723

Open Ended Card Edge: 00-9159-BTB

4 Position

4 WAY SINGLE PART PCB STRIP CONNECTOR – OPEN ENDED

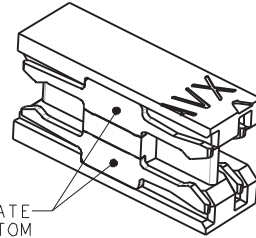
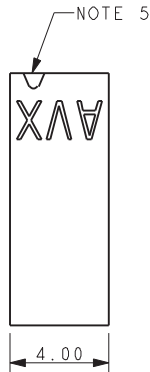

SECTION VIEW THROUGH CONTACT

POSITION

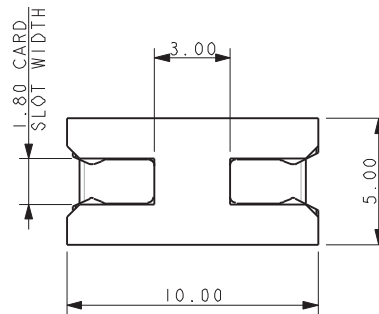
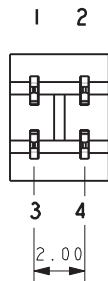

NOTES:

1. INSULATOR MATERIAL NYLON 46, UL94 V-0.
COLOR REFER TO PAGE 77.
2. CONTACT MATERIAL COPPER ALLOY, TIN PLATED
3. PARTS TO BE SUPPLIED IN BAGS, 1000 PIECES PER BAG.
4. GENERAL TOLERANCE $\pm 0.20\text{MM}$ UNLESS STATED.
5. ARROW ADJACENT TO CONTACT POSITION 1.
6. PCB PAD, TIN PLATED OR TIN PLATED WITH GOLD FLASH.
7. FURTHER DETAILS REFER TO ELCO SPECIFICATION 201-01-144.

SUGGESTED PCB LAYOUT

PADS THE SAME UPPER AND LOWER FACES
PCB THICKNESS $1.60 \pm 0.10\text{MM}$ (OVER PADS)

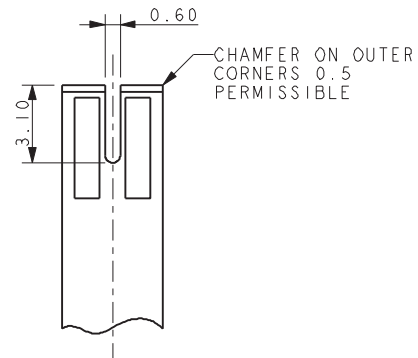
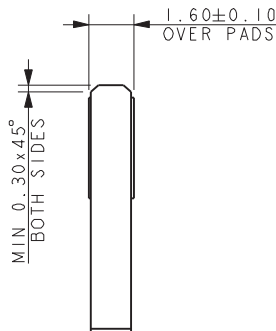
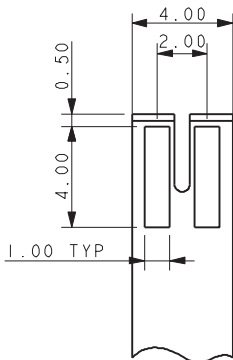

Open Ended Card Edge: 00-9159-BTB

6 Position

6 WAY SINGLE PART PCB STRIP CONNECTOR – OPEN ENDED

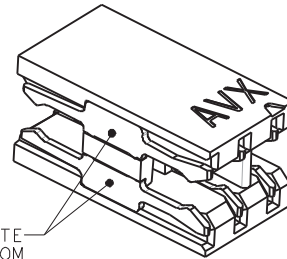
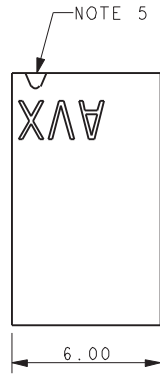

CONTACTS SEPERATE
TOP AND BOTTOM

SECTION VIEW THROUGH CONTACT

POSITION

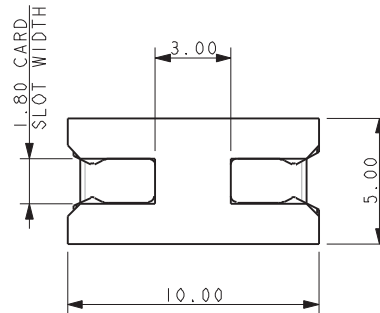
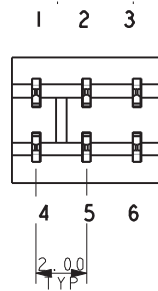

NOTES:

1. INSULATOR MATERIAL NYLON 46, UL94 V-0.
COLOR REFER TO PAGE 77.
2. CONTACT MATERIAL COPPER ALLOY, TIN PLATED
3. PARTS TO BE SUPPLIED IN BAGS, 1000 PIECES PER BAG.
4. GENERAL TOLERANCE $\pm 0.20\text{MM}$ UNLESS STATED.
5. ARROW ADJACENT TO CONTACT POSITION 1.
6. PCB PAD, TIN PLATED OR TIN PLATED WITH GOLD FLASH.
7. FURTHER DETAILS REFER TO ELCO SPECIFICATION 201-01-144.

SUGGESTED PCB LAYOUT

PADS THE SAME UPPER AND LOWER FACES
PCB THICKNESS $1.60 \pm 0.10\text{MM}$ (OVER PADS)

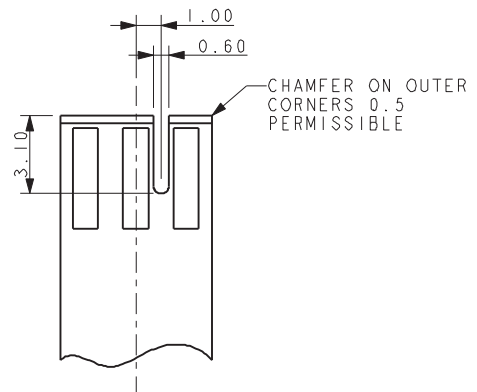
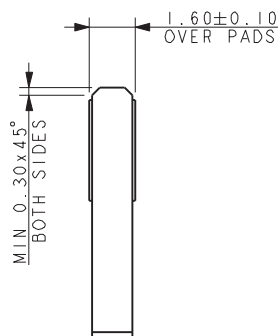
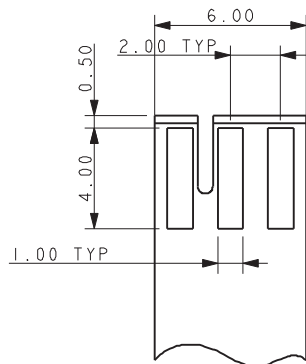

Open Ended Card Edge: 00-9159-BTB

8 Position

8 WAY SINGLE PART PCB STRIP CONNECTOR – OPEN ENDED

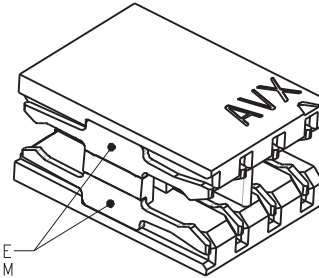

CONTACTS SEPERATE
TOP AND BOTTOM

SECTION VIEW THROUGH CONTACT

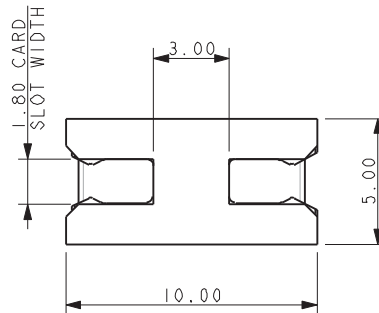
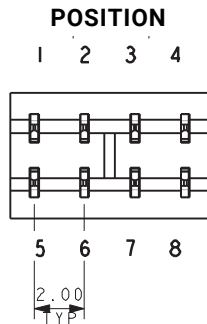

NOTES:

1. INSULATOR MATERIAL NYLON 46, UL94 V-0.
COLOR REFER TO PAGE 77.
2. CONTACT MATERIAL COPPER ALLOY, TIN PLATED
3. PARTS TO BE SUPPLIED IN BAGS, 1000 PIECES PER BAG.
4. GENERAL TOLERANCE $\pm 0.20\text{MM}$ UNLESS STATED.
5. ARROW ADJACENT TO CONTACT POSITION 1.
6. PCB PAD, TIN PLATED OR TIN PLATED WITH GOLD FLASH.
7. FURTHER DETAILS REFER TO ELCO SPECIFICATION 201-01-144.

SUGGESTED PCB LAYOUT

PADS THE SAME UPPER AND LOWER FACES
PCB THICKNESS $1.60 \pm 0.10\text{MM}$ (OVER PADS)

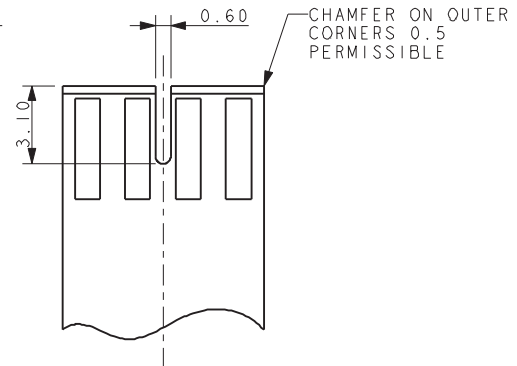
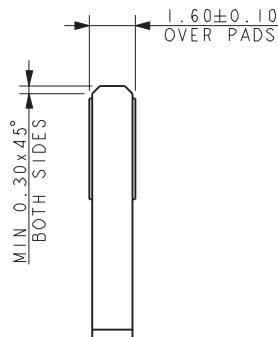
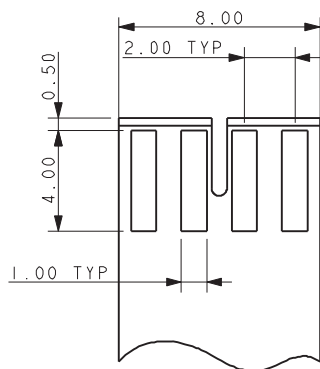

Open Ended Card Edge: 00-9159-BTB

10 Position

10 WAY SINGLE PART PCB STRIP CONNECTOR – OPEN ENDED

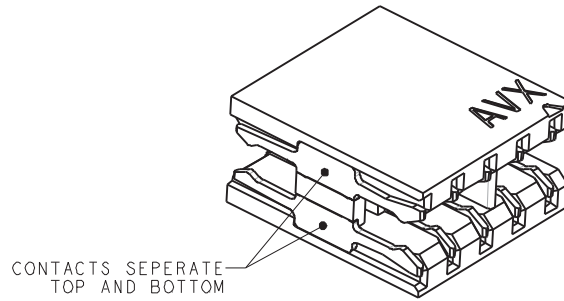
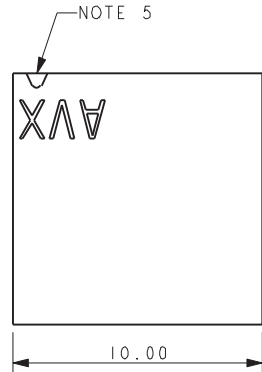

SECTION VIEW THROUGH CONTACT

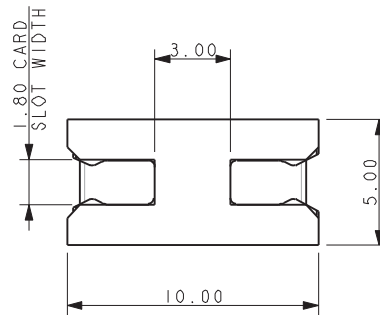
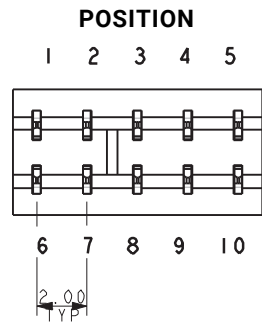

NOTES:

1. INSULATOR MATERIAL NYLON 46, UL94 V-0. COLOR REFER TO PAGE 77.
2. CONTACT MATERIAL COPPER ALLOY, TIN PLATED
3. PARTS TO BE SUPPLIED IN BAGS, 1000 PIECES PER BAG.
4. GENERAL TOLERANCE $\pm 0.20\text{MM}$ UNLESS STATED.
5. ARROW ADJACENT TO CONTACT POSITION 1.
6. PCB PAD, TIN PLATED OR TIN PLATED WITH GOLD FLASH.
7. FURTHER DETAILS REFER TO ELCO SPECIFICATION 201-01-144.

SUGGESTED PCB LAYOUT

PADS THE SAME UPPER AND LOWER FACES
PCB THICKNESS $1.60 \pm 0.10\text{MM}$ (OVER PADS)

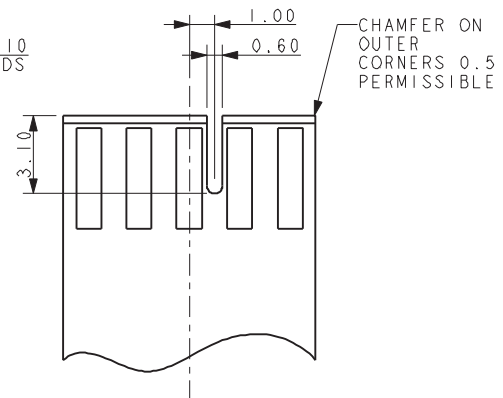
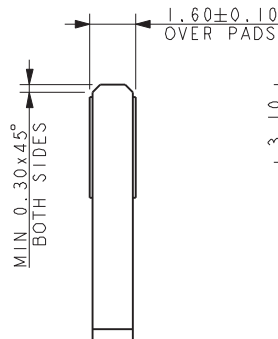
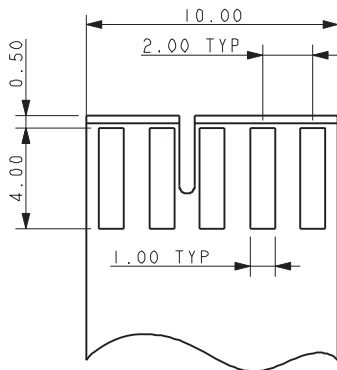

Inverted Thru Board Card Edge: 00-9159-BTB

General Description

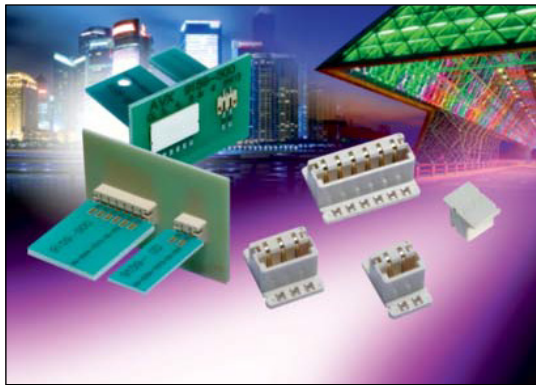

KYOCERA AVX has developed the 1-Piece bottom entry card edge connector to allow a perpendicular PCB to be mated to a top mounted main FR4 or metal core PCB from the bottom side. The most popular application on the market is in the LED bulb market where the FR4 driver card needs to mate to the top pads on a metal core LED board. A unique design feature of the KYOCERA AVX connector is that it allows for both a 1.6mm and 0.8mm mating PCB thickness, giving designers flexibility in their PCB layout and selection. The additional "Anti-Touch" cap can be ordered pre-assembled onto the connector or separately. This component protects an individual for electrical contact if the lens comes off or the bulb is broken. This is a UL mandated safety requirement.

The connectors offer a range of 2 positions to 6 positions in order to add additional functionality in the application design such as color control or specific control lines. The connector is UL rated with halogen free material and capable of operating temperatures up to 120°C.

APPLICATIONS

- Provides perpendicular, bottom entry PCB mating to a top mounted card edge contact based connector
- Reference application notes 201-01-137
- Reference Product Specification 201-01-132UL

FEATURES AND BENEFITS

- Available 2p-6p for added design functionality and color control in bulb applications
- Low profile top mounted design does not interfere with LED's
- Gold plated BeCu contact system for high reliability in harsh environments
- Accepts both 0.8mm and 1.6mm PCB's for added design options

ELECTRICAL

- Current Rating: 2 Amps / Contact
- Voltage Rating: 300 VAC

ENVIRONMENTAL

- Operating Temperature: -40°C to +125°C

MECHANICAL

- Insulator Material: Halogen Free Nylon UL94VO
- Contact Material: Beryllium Copper
- Plating: Gold / Tin over Nickel
- Durability 10 Cycles

HOW TO ORDER

00
Prefix

9159
Series

00X
Number of Ways

Code	No of Ways	Details
002	2	Page 83
003	3	Page 84
004	4	Page 85
005	5	Page 86
006	6	Page 87

50X
Single Part PCB Strip Connector

501 = Through The Board, Edge Card, No Cap
502 = Through The Board, Edge Card, Cap Fitted 1.6±0.10

9
Insulator Color

Code	Color	Application
9	White	UL Approved Standard

06
Packaging Options

06 = Gold Plating on Nos with Tin on Tails



Certification: UL File #E90723

Inverted Thru Board Card Edge: 00-9159-BTB

2 Position

2 WAY THROUGH THE BOARD MATING EDGE CARD CONNECTOR

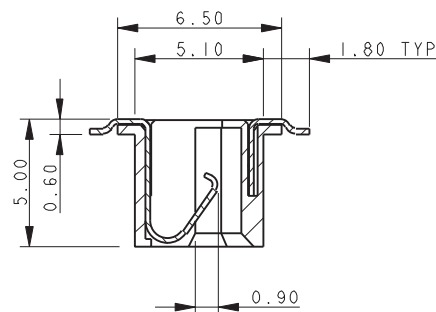
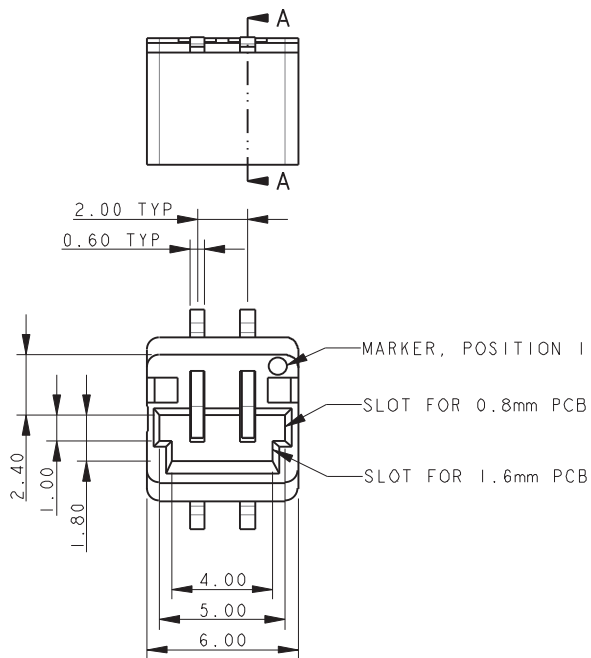

SECTION A-A

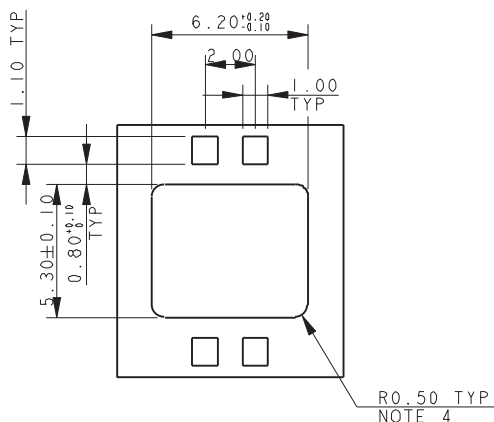
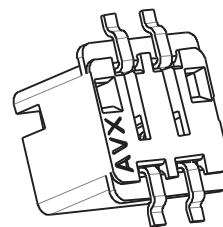

MOUNTING PCB
(TOP SIDE)

PACKING DETAILS

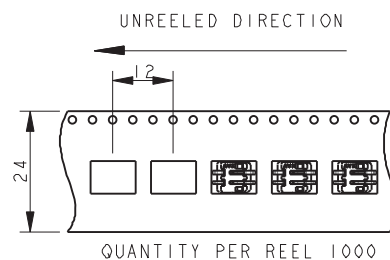
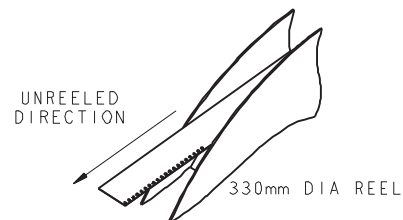

NOTES:

1. THROUGH THE BOARD 2 WAY EDGE CARD CONNECTOR. FOR FURTHER DETAILS REFER TO PRODUCT SPECIFICATION 201-01-136.
2. FOR MATING PCB EITHER 0.8MM OR 1.6MM THICK. REFER TO PAGE 88 FOR MATING PCB DETAILS.
3. CONNECTOR TOP MOUNTING ON PCB.
4. UP TO 0.5MM RAD TO MATCH CONNECTOR PROFILE.
5. ALL DIMENSIONS ±0.20 UNLESS TOLERANCE SPECIFIED.
6. INSULATOR: PAR4T, GLASS FILLED, HALOGEN FREE, UL94 V-0, COLOR SEE PAGE 82.
7. CONTACT: COPPER ALLOW, NICKEL PLATED WITH GOLD FLASH ON NOSE AND TIN ON TAILS.
8. BRACKET: COPPER ALLOY, PLATING TIN OVER NICKEL.
9. PACKING IN TAPE AND REEL, 1000 PIECES PER REEL.
10. CONTACT TAILS COPLINARITY WITHIN 0.10.
11. REFER TO PAGE 91 FOR MATCHING PROTECTING CAP.
12. UL REFERENCE E90723.

Inverted Thru Board Card Edge: 00-9159-BTB

3 Position

3 WAY THROUGH THE BOARD MATING EDGE CARD CONNECTOR

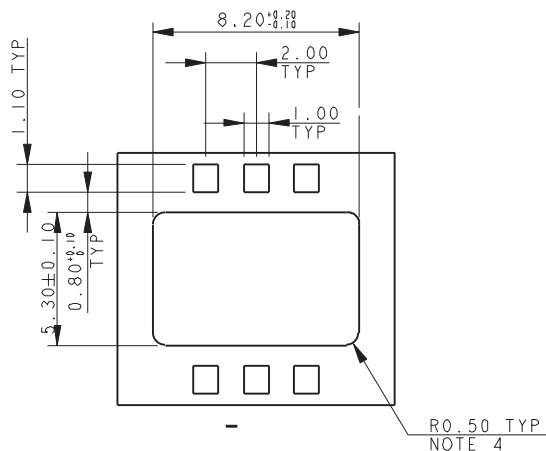
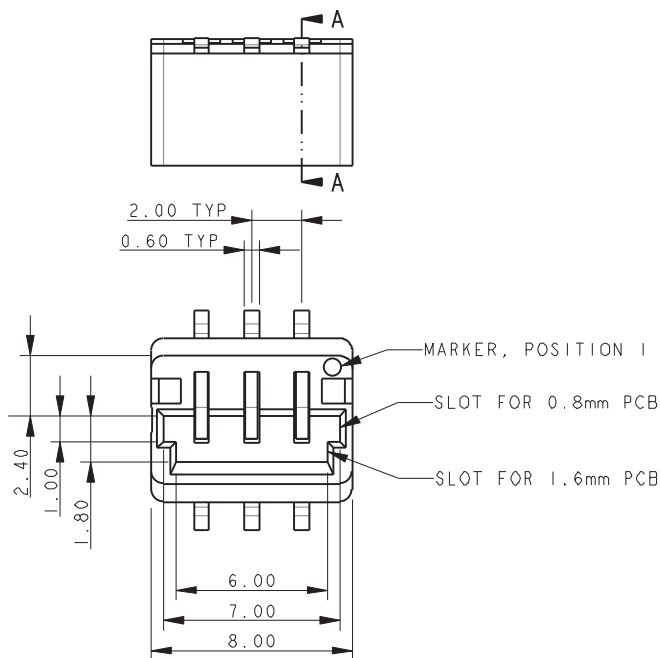

**MOUNTING PCB
(TOP SIDE)**

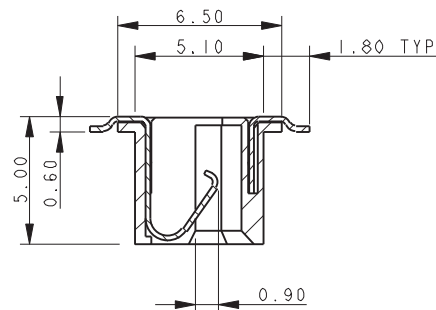

SECTION A-A

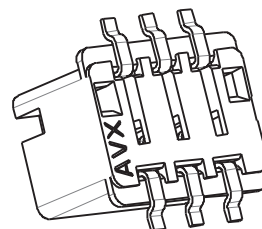

PACKING DETAILS

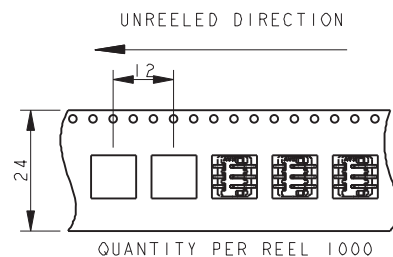
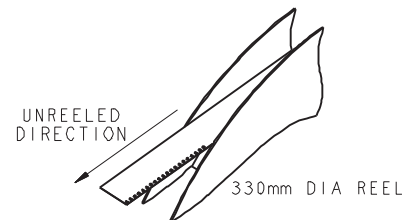

NOTES:

1. THROUGH THE BOARD 3 WAY EDGE CARD CONNECTOR. FOR FURTHER DETAILS REFER TO PRODUCT SPECIFICATION 201-01-136.
2. FOR MATING PCB EITHER 0.8MM OR 1.6MM THICK. REFER TO PAGE 88 FOR MATING PCB DETAILS.
3. CONNECTOR TOP MOUNTING ON PCB.
4. UP TO 0.5MM RAD TO MATCH CONNECTOR PROFILE.
5. ALL DIMENSIONS ±0.20 UNLESS TOLERANCE SPECIFIED.
6. INSULATOR: PAR4T, GLASS FILLED, HALOGEN FREE, UL94 V-0, COLOR SEE PAGE 82.
7. CONTACT: COPPER ALLOW, NICKEL PLATED WITH GOLD FLASH ON NOSE AND TIN ON TAILS.
8. BRACKET: COPPER ALLOY, PLATING TIN OVER NICKEL.
9. PACKING IN TAPE AND REEL, 1000 PIECES PER REEL.
10. CONTACT TAILS COPLINARITY WITHIN 0.10.
11. REFER TO PAGE 91 FOR MATCHING PROTECTING CAP.
12. UL REFERENCE E90723.

Inverted Thru Board Card Edge: 00-9159-BTB

4 Position

4 WAY THROUGH THE BOARD MATING EDGE CARD CONNECTOR

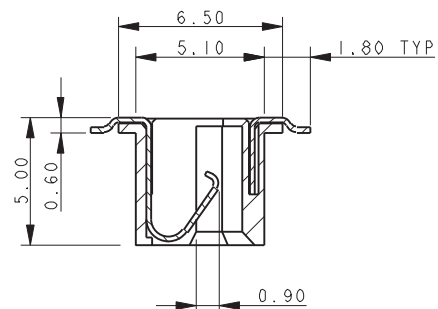
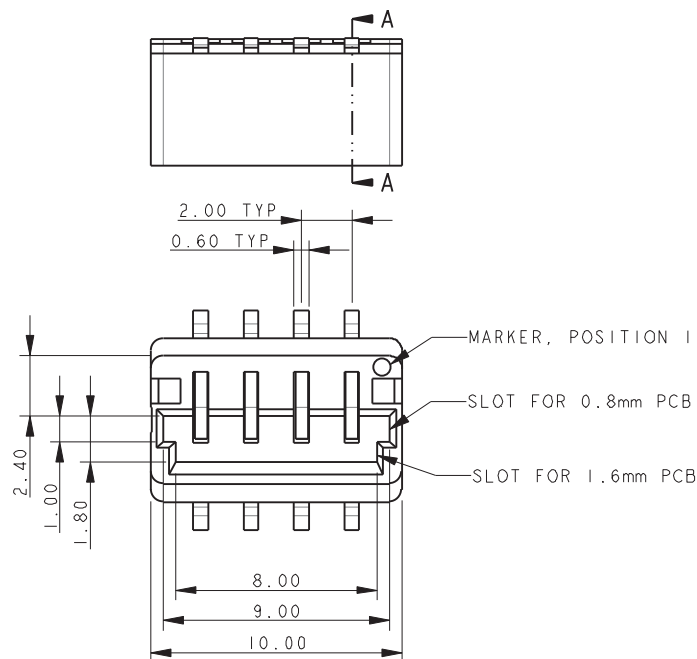

SECTION A-A

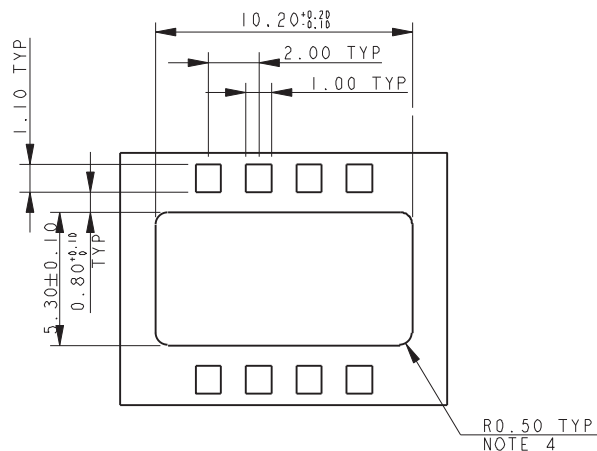
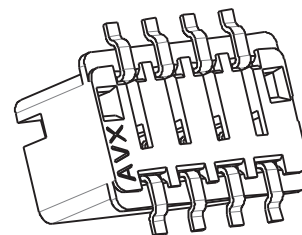

MOUNTING PCB
(TOP SIDE)

PACKING DETAILS

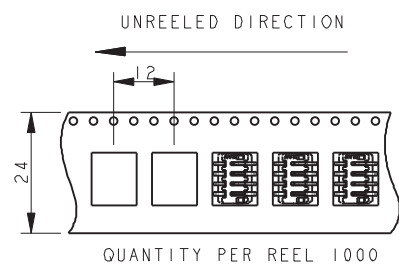
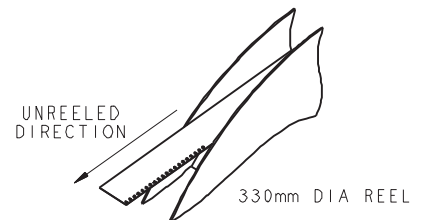

NOTES:

1. THROUGH THE BOARD 4 WAY EDGE CARD CONNECTOR. FOR FURTHER DETAILS REFER TO PRODUCT SPECIFICATION 201-01-136.
2. FOR MATING PCB EITHER 0.8MM OR 1.6MM THICK. REFER TO PAGE 88 FOR MATING PCB DETAILS.
3. CONNECTOR TOP MOUNTING ON PCB.
4. UP TO 0.5MM RAD TO MATCH CONNECTOR PROFILE.
5. ALL DIMENSIONS ± 0.20 UNLESS TOLERANCE SPECIFIED.
6. INSULATOR: PAR4T, GLASS FILLED, HALOGEN FREE, UL94 V-0, COLOR SEE PAGE 82.
7. CONTACT: COPPER ALLOW, NICKEL PLATED WITH GOLD FLASH ON NOSE AND TIN ON TAILS.
8. BRACKET: COPPER ALLOY, PLATING TIN OVER NICKEL.
9. PACKING IN TAPE AND REEL, 1000 PIECES PER REEL.
10. CONTACT TAILS COPLINARITY WITHIN 0.10.
11. REFER TO PAGE 91 FOR MATCHING PROTECTING CAP.
12. UL REFERENCE E90723.

Inverted Thru Board Card Edge: 00-9159-BTB

5 Position

5 WAY THROUGH THE BOARD MATING EDGE CARD CONNECTOR

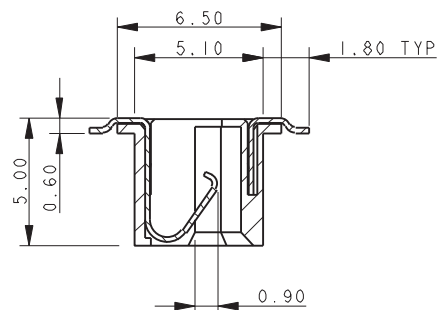
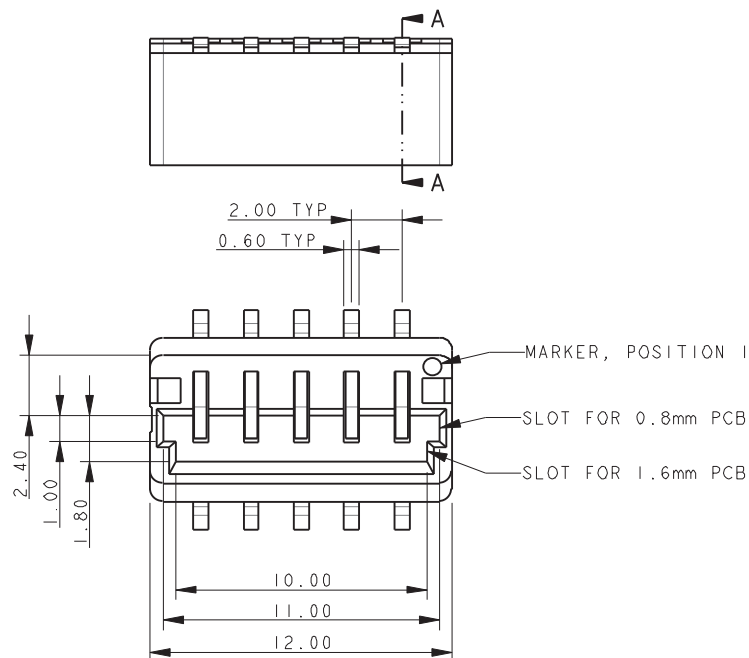

SECTION A-A

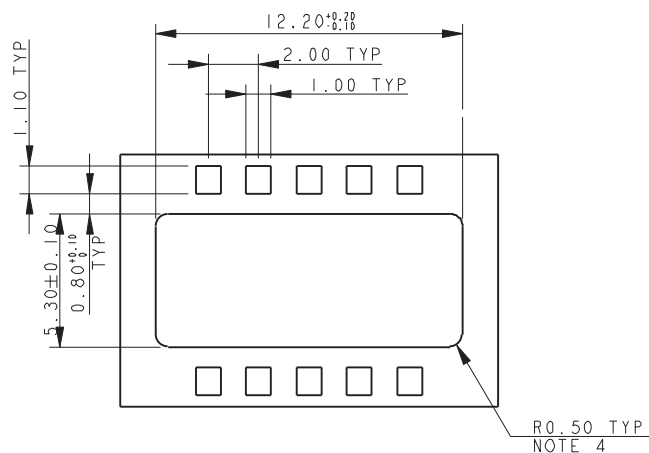
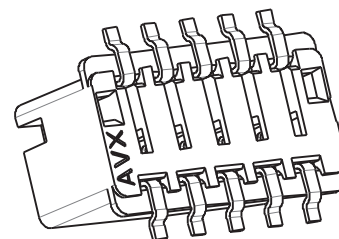

MOUNTING PCB
(TOP SIDE)

PACKING DETAILS

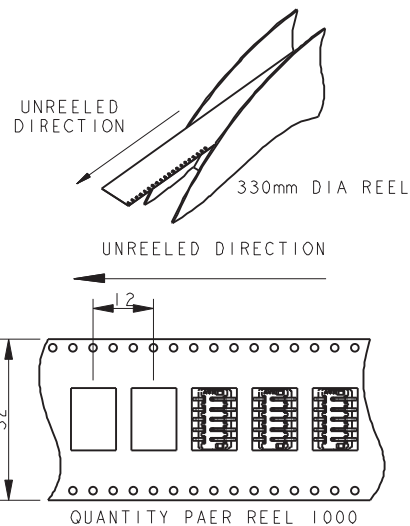

NOTES:

1. THROUGH THE BOARD 5 WAY EDGE CARD CONNECTOR. FOR FURTHER DETAILS REFER TO PRODUCT SPECIFICATION 201-01-136.
2. FOR MATING PCB EITHER 0.8MM OR 1.6MM THICK. REFER TO PAGE 88 FOR MATING PCB DETAILS.
3. CONNECTOR TOP MOUNTING ON PCB.
4. UP TO 0.5MM RAD TO MATCH CONNECTOR PROFILE.
5. ALL DIMENSIONS ±0.20 UNLESS TOLERANCE SPECIFIED.
6. INSULATOR: PAR4T, GLASS FILLED, HALOGEN FREE, UL94 V-0, COLOR SEE PAGE 82.
7. CONTACT: COPPER ALLOW, NICKEL PLATED WITH GOLD FLASH ON NOSE AND TIN ON TAILS.
8. BRACKET: COPPER ALLOY, PLATING TIN OVER NICKEL.
9. PACKING IN TAPE AND REEL, 1000 PIECES PER REEL.
10. CONTACT TAILS COPLINARITY WITHIN 0.10.
11. REFER TO PAGE 91 FOR MATCHING PROTECTING CAP.
12. UL REFERENCE E90723.

Inverted Thru Board Card Edge: 00-9159-BTB

6 Position

6 WAY THROUGH THE BOARD MATING EDGE CARD CONNECTOR

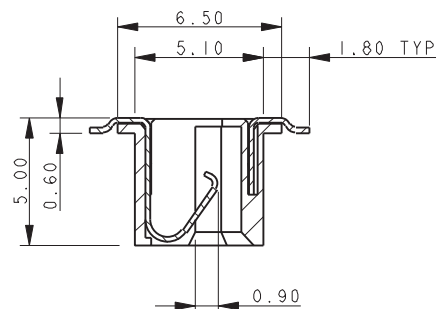
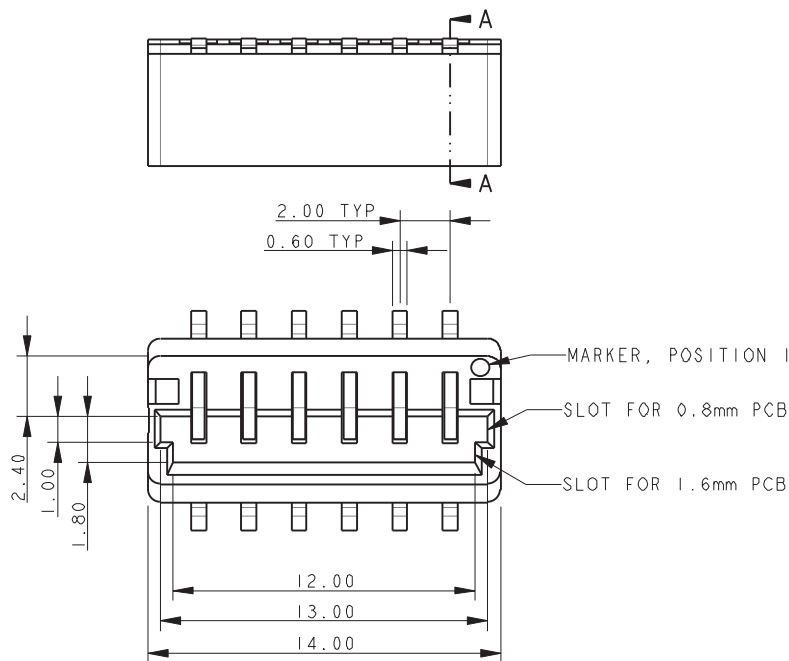

SECTION A-A

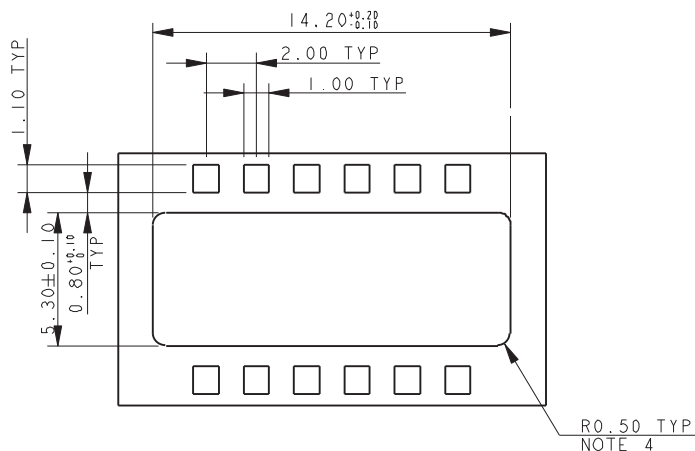
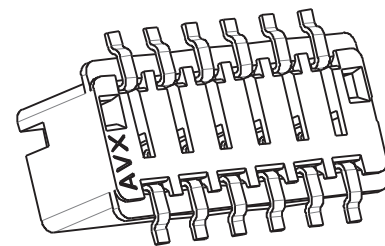

MOUNTING PCB (TOP SIDE)

PACKING DETAILS

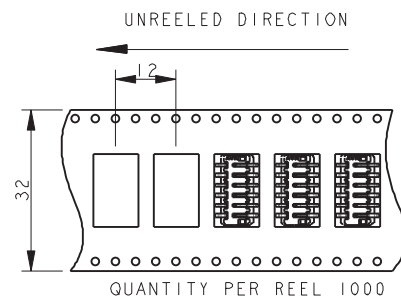
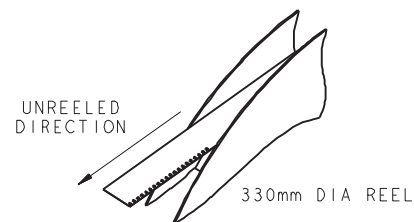

NOTES:

1. THROUGH THE BOARD 6 WAY EDGE CARD CONNECTOR. FOR FURTHER DETAILS REFER TO PRODUCT SPECIFICATION 201-01-136.
2. FOR MATING PCB EITHER 0.8MM OR 1.6MM THICK. REFER TO PAGE 88 FOR MATING PCB DETAILS.
3. CONNECTOR TOP MOUNTING ON PCB.
4. UP TO 0.5MM RAD TO MATCH CONNECTOR PROFILE.
5. ALL DIMENSIONS \pm 0.20 UNLESS TOLERANCE SPECIFIED.
6. INSULATOR: PAR4T, GLASS FILLED, HALOGEN FREE, UL94 V-0, COLOR SEE PAGE 82.
7. CONTACT: COPPER ALLOW, NICKEL PLATED WITH GOLD FLASH ON NOSE AND TIN ON TAILS.
8. BRACKET: COPPER ALLOY, PLATING TIN OVER NICKEL.
9. PACKING IN TAPE AND REEL, 1000 PIECES PER REEL.
10. CONTACT TAILS COPLINARITY WITHIN 0.10.
11. REFER TO PAGE 91 FOR MATCHING PROTECTING CAP.
12. UL REFERENCE E90723.

Inverted Thru Board Card Edge: 00-9159-BTB

Thru Board Mating Edge Card Connector – With Cap

THROUGH THE BOARD MATING EDGE CARD CONNECTOR – WITH CAP 00-9159-00X-502-X06

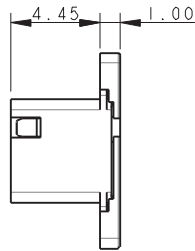
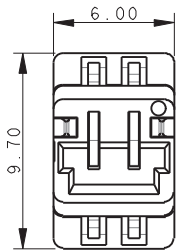

00-9159-002-502-906

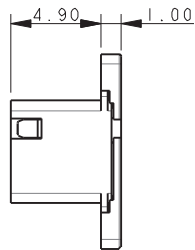
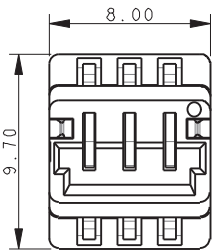

00-9159-003-502-906

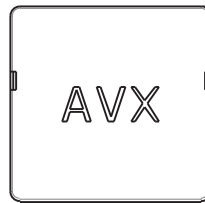
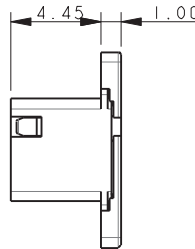
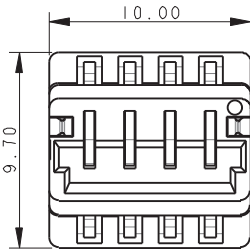

00-9159-004-502-906

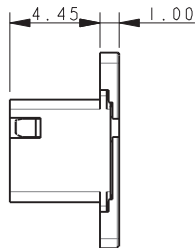
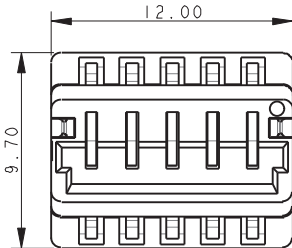

00-9159-005-502-906

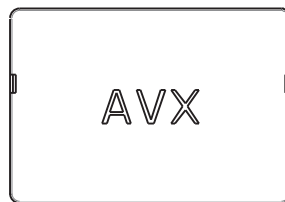
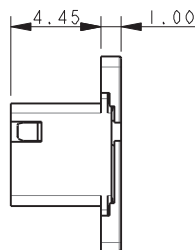
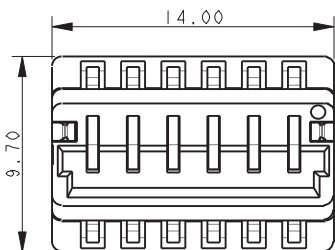

00-9159-006-502-906

NOTES:

1. 00-9159-00X-501-X06 WITH CAP SUPPLIED FITTED.
2. DRAWINGS SHOW OUTLINE DIMENSIONS OF THE 00-9159-00X-502-X06 ASSEMBLIES. ALL OTHER DETAILS ARE AS 00-9159-00X-501-X06 ON PAGES 83-87.
3. GENERAL TOLERANCE ± 0.20 .
4. PACKING ORIENTATION.
5. UL REFERENCE E90723.

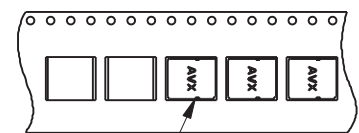

NOTE 4

Inverted Thru Board Card Edge: 00-9159-BTB

Thru Board Mating Edge Card Connector – Mating PCB

THROUGH THE BOARD MATING EDGE CARD CONNECTOR – MATING PCB

MATING PCB – 0.8MM PCB

MATING PCB – 1.6MM PCB

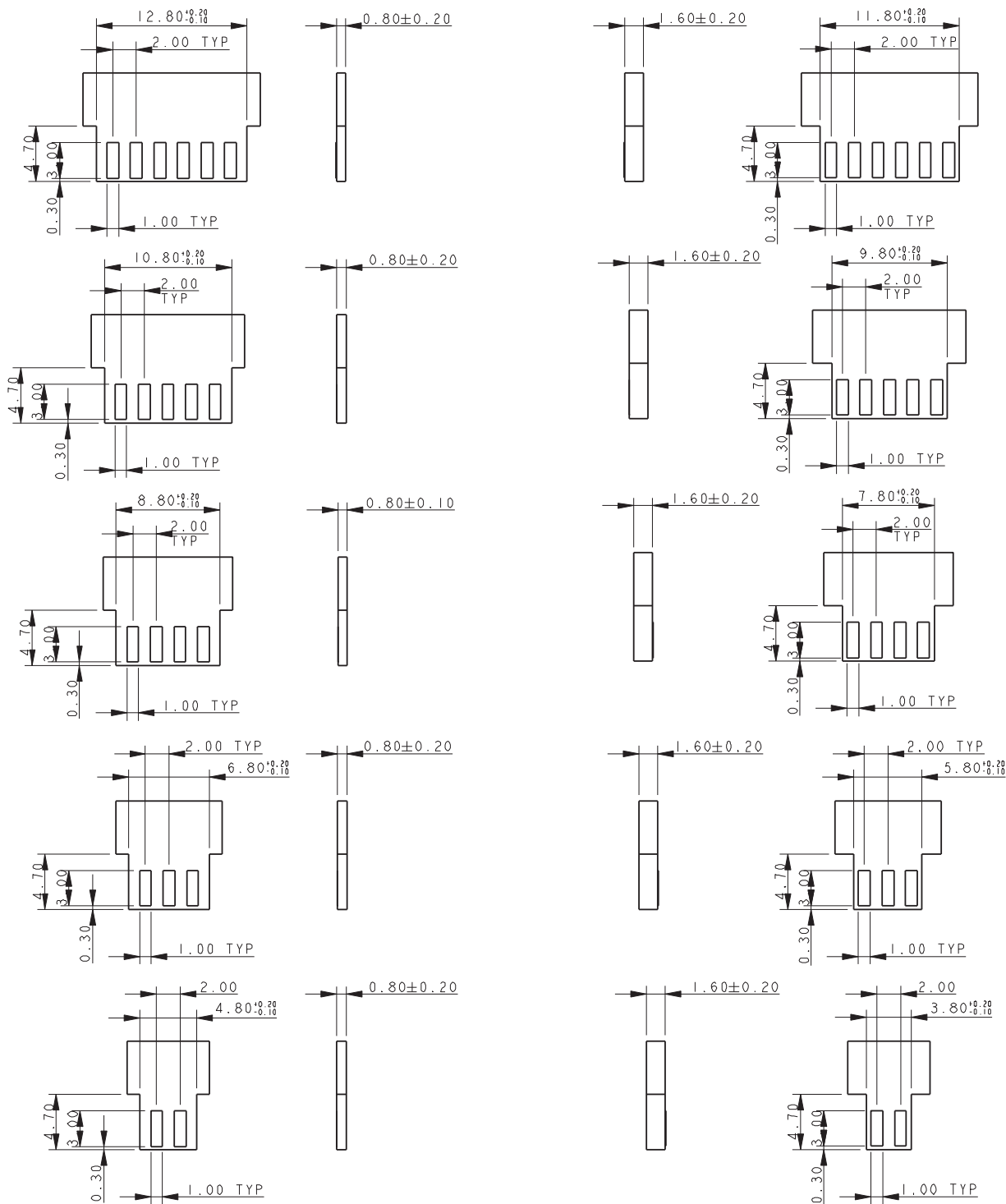

NOTES:

1. CORRECT DIMENSIONS FOR EITHER 0.80MM OR F1.60MM PCB THICKENSS MUST BE USED.
2. THICKNESS OF PCB INCLUDES ALL LAYERS INCLUDING COPPER AND PLATING.
3. PADS TO BE PLATED GOLD OVER NICKEL UNDERCOAT.
4. GENERAL TOLERANCE ± 0.10 UNLESS STATED.

Inverted Thru Board Card Edge: 00-9159-BTB

Assembly

THROUGH THE BOARD MATING EDGE CARD CONNECTOR

CONNECTOR/PCB ASSEMBLY 0.8MM MATING PCB NO CAP

CONNECTOR/PCB ASSEMBLY 1.6MM MATING PCB WITH CAP

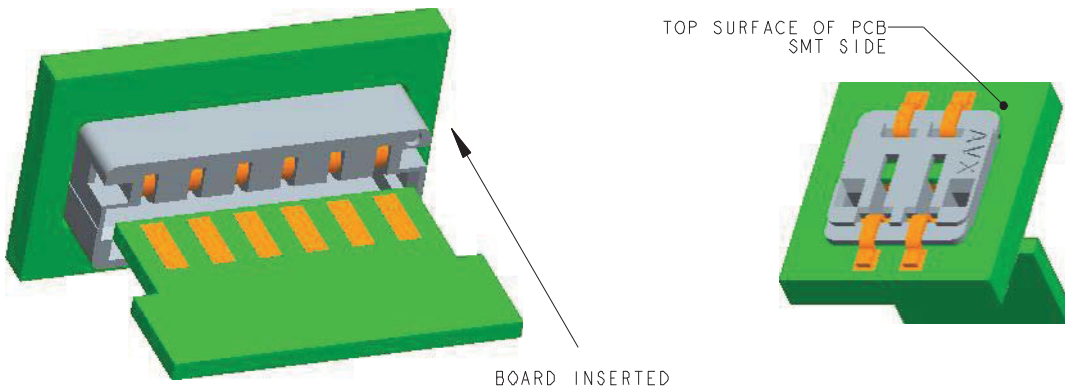
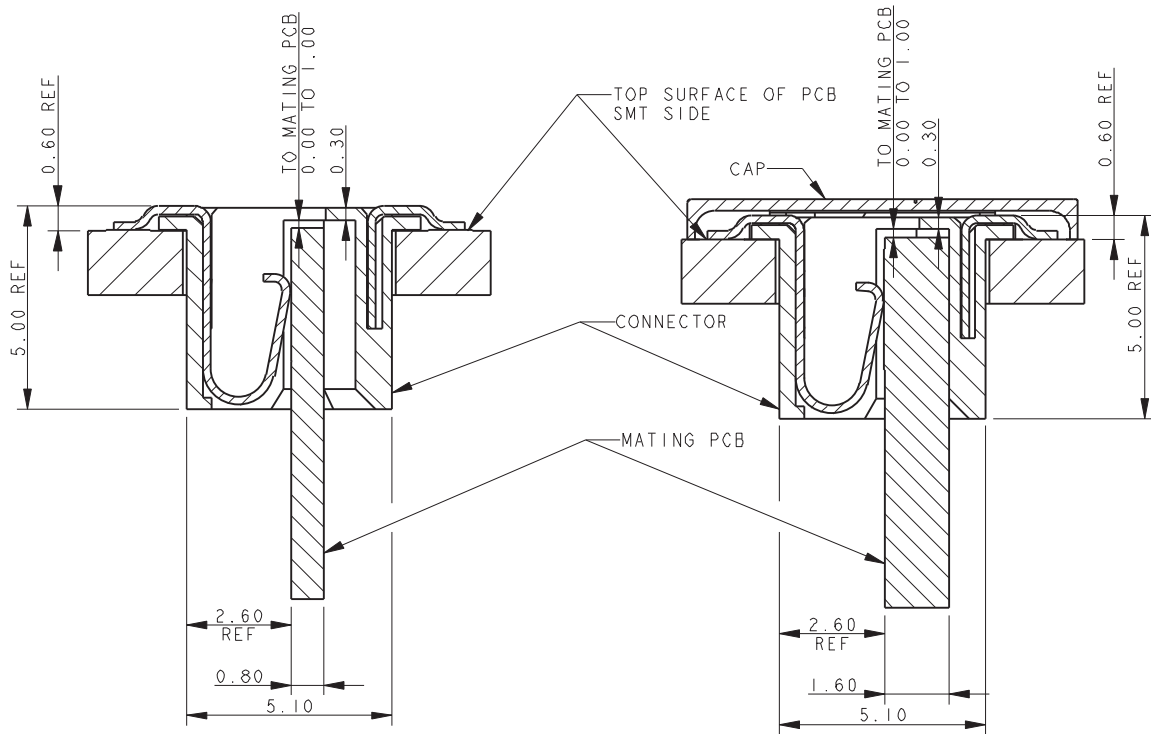

NOTES:

1. THROUGH THE BOARD EDGE CARD CONNECTOR.
2. FOR MATING PCB EITHER 0.8MM OR 1.6MM THICK. REFER TO PAGE 88 FOR MATING PCB DETAILS.
3. CONNECTOR TOP MOUNTING ON PCB.
4. PAD DETAILS ON THE MATING PCB ALLOW CONTACT TO BE MADE IN ANY POSITION FROM THE STOP FACE UP TO 1MM FROM THE STOP FACE.
5. GENERAL TOLERANCE ± 0.20 UNLESS STATED.

Inverted Thru Board Card Edge: 00-9159-BTB

Accessory – Protection Cap

ACCESSORY – PROTECTING CAP

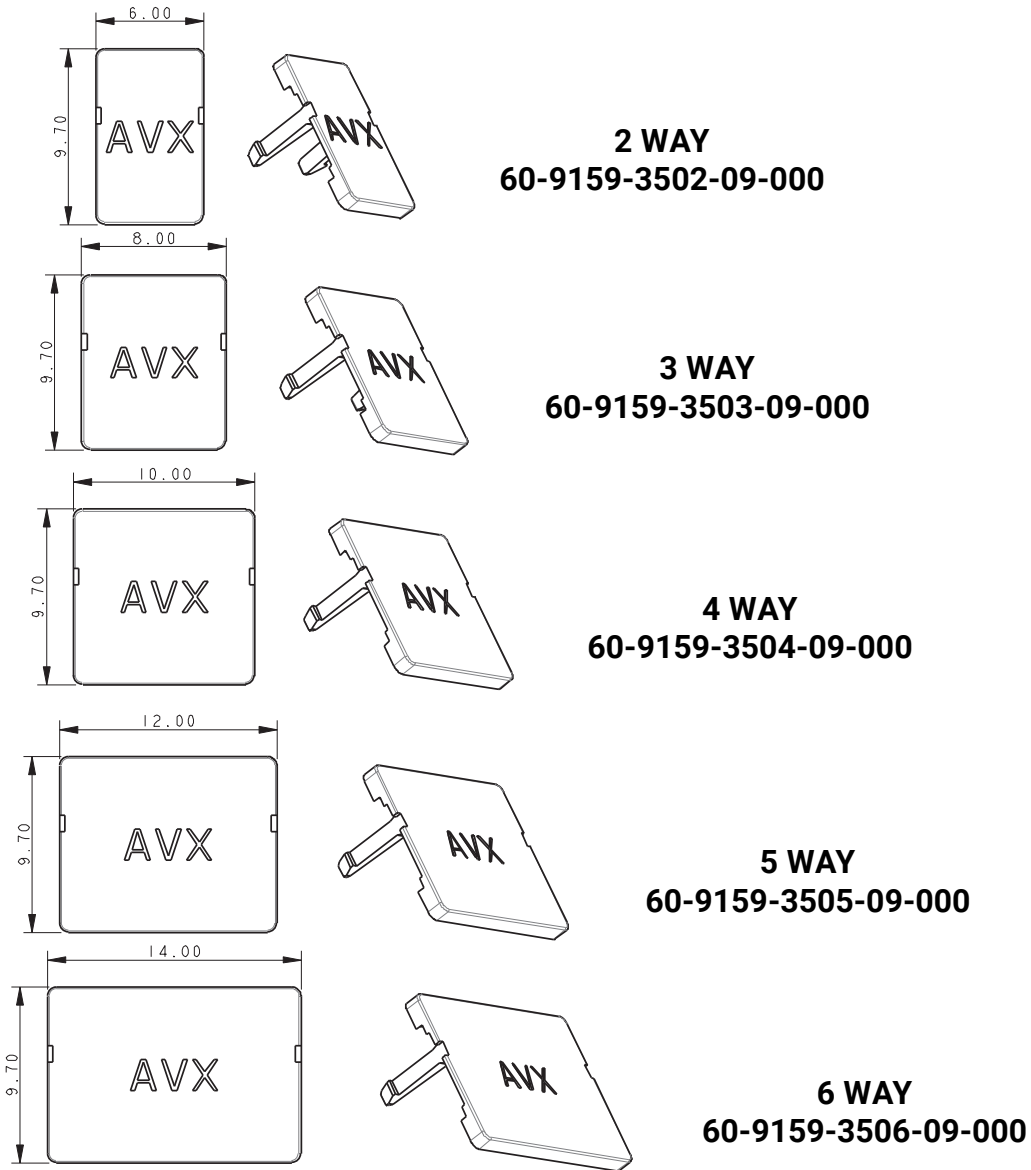

NOTES:

1. PROTECTING CAP, ACCESSORY, NOT SUPPLIED WITH CONNECTOR.
2. CLIPS TO TOP OF CONNECTOR TO COVE ALL METAL COMPONENTS.
3. MATERIAL: PA4T, GLASS FILLED, HALOGEN FREE, UL94 V-0. COLOR CODE REFER TO PAGE 82, "X" IN PART NUMBER.
4. SUPPLIED IN BAGS OF 100 PIECES.
5. GENERAL TOLERANCE ± 0.20 .
6. UL REFERENCE E90723.

ASSEMBLED CAP

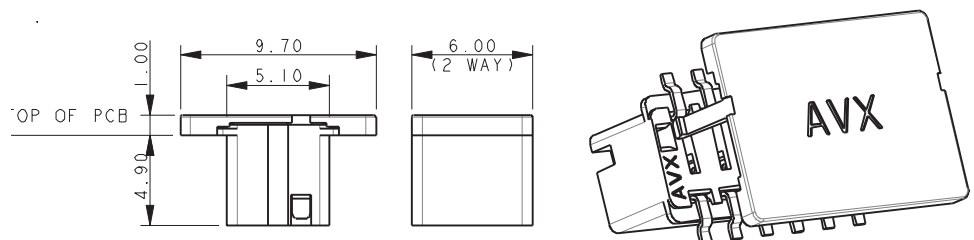

Vertical Top Entry Card Edge: 00-9159-BTB

General Description

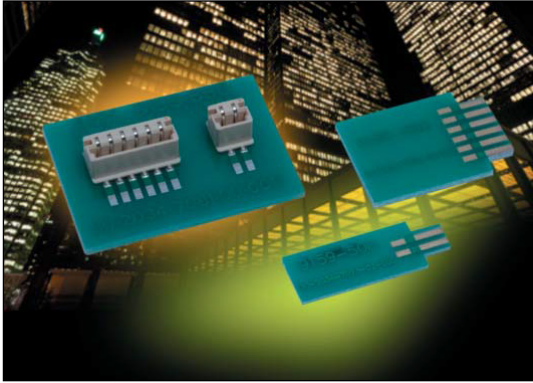

KYOCERA AVX continues to develop unique connectors to fill the gap in the industrial market, specifically as it relates to low pin count requirements. The newest addition to KYOCERA AVX's broadening line of one piece card edge connectors is the 2p-6p top entry version which complements the bottom entry version released last year. This new configuration will allow small perpendicular daughter cards to be plugged in from the top side of the main board. The single connector option offers an alternative to the more traditional and costly two piece solution.

This small connector is packed with several key features that provide significant functionality in a broad range of robust industrial applications. The contact system is gold plated for enhanced reliability, signal integrity and full 2A/contact current rating. The PCB board opening is dual slotted to accept either a 0.8mm or 1.6mm thick daughter card within the same connector body.

APPLICATIONS

- Provides a one piece connector solution for low pin count perpendicular PCB mating in industrial applications
- Facilitates easy plug ability for small module/programming cards

FEATURES AND BENEFITS

- Amp per contact current rating meets robust industrial application requirements
- Removable pick and place cap supports robotic placement and SMT termination
- Gold plated BeCu contact system for high reliability in harsh environments
- Accepts both 0.8mm and 1.6mm PCB's for added design options

ELECTRICAL

- Current Rating: 2 Amps / Contact
- Voltage Rating: 300 VAC

ENVIRONMENTAL

- Operating Temperature: -40°C to +125°C

MECHANICAL

- Insulator Material: Nylon UL94VO
- Contact Material: Beryllium Copper
- Plating: Gold / Tin over Nickel
- Durability 10 Cycles

HOW TO ORDER

00
Prefix

9159
Series

00X
Number of Ways

Code	No of Ways	Details
002	2	Page 93
003	3	Page 94
004	4	Page 95
005	5	Page 96
006	6	Page 97

551
Single Part PCB Strip Connector
551 = Top Mounting on Board Edge Card

9
Insulator Color

Code	Color	Application
9	White	UL Approved Standard

06
Packaging Options
06 = Gold Plating on Nos with Tin on Tails

Certification: UL File #E90723



Vertical Top Entry Card Edge: 00-9159-BTB

2 Position

2 WAY TOP MOUNTING EDGE CARD CONNECTOR

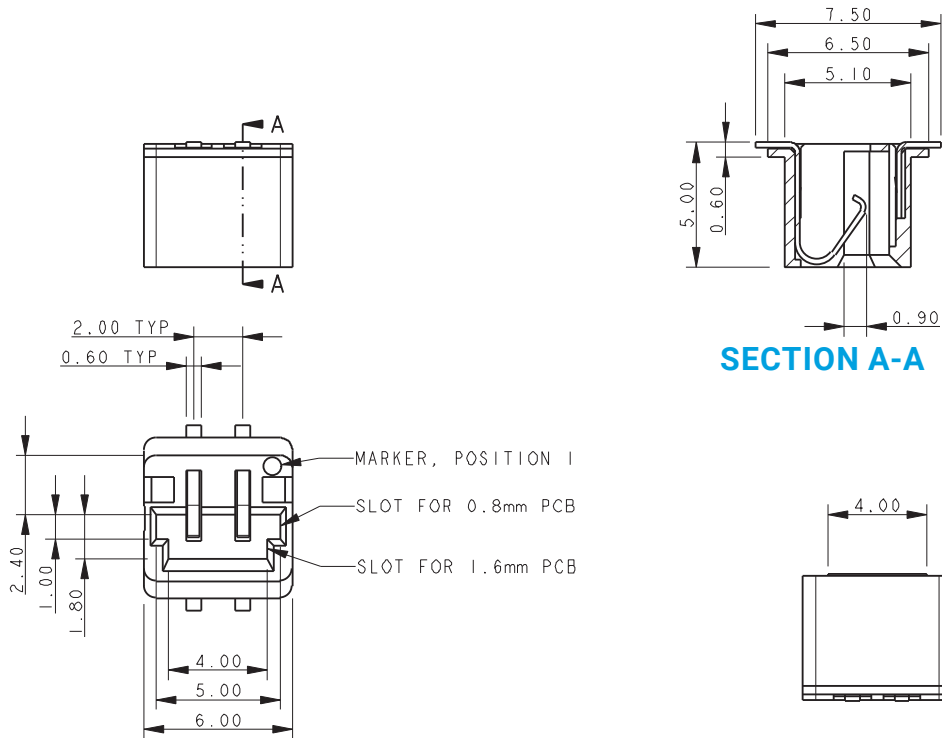

SUGGESTED PCB LAYOUT

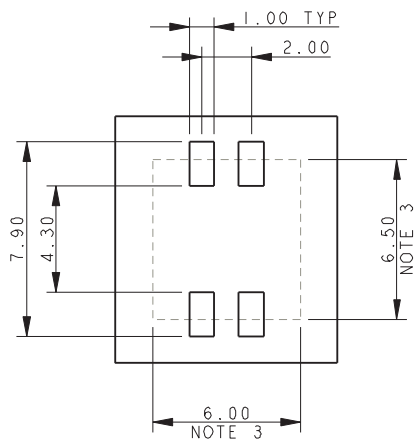

PICK AND PLACE TAPE
REMOVE AFTER SOLDERING

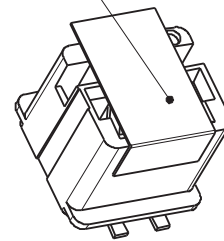

PACKING DETAILS

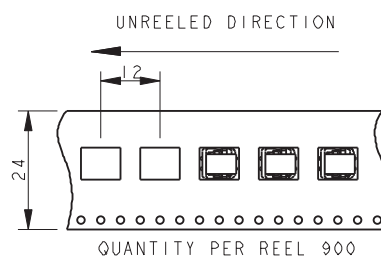
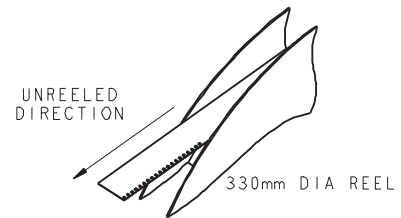

NOTES:

1. 5159-500 SERIES TOP MOUNTING EDGE CARD CONNECTOR, 1 WAY. FOR FURTHER DETAILS REFER TO PRODUCT SPECIFICATION 201-01-136 AND APPLICATION NOTES 201-01-137.
2. FOR MATING PCB EITHER 0.8MM OR 1.6MM THICK PCB. (DETAILS SAME AS 9159-500), REFER TO PAGE 98.
3. CONNECTOR OUTLINE.
4. ALL DIMENSIONS ± 0.20 UNLESS TOLERANCE SPECIFIED.
5. INSULATOR: PA4T, GLASS FILLED, HALOGEN FREE, UL94 V-0, COLOR REFER TO PAGE 92.
6. CONTACT: COPPER ALLOY, NICKEL PLATED WITH GOLD FLASH ON NOSE AND TIN ON TAILS.
7. BRACKET: COPPER ALLOY, PLATING, TIN OVER NICKEL.
8. PACKING IN TAPE AND REEL, 900 PIECES PER REEL.
9. CONTACT TAILS COPLINARITY WITHIN 0.10.
10. UL PRODUCT REFERENCE E90723 (US AND CANADA).

Vertical Top Entry Card Edge: 00-9159-BTB

3 Position

3 WAY TOP MOUNTING EDGE CARD CONNECTOR

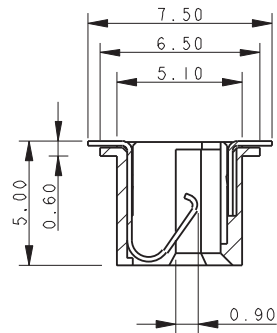
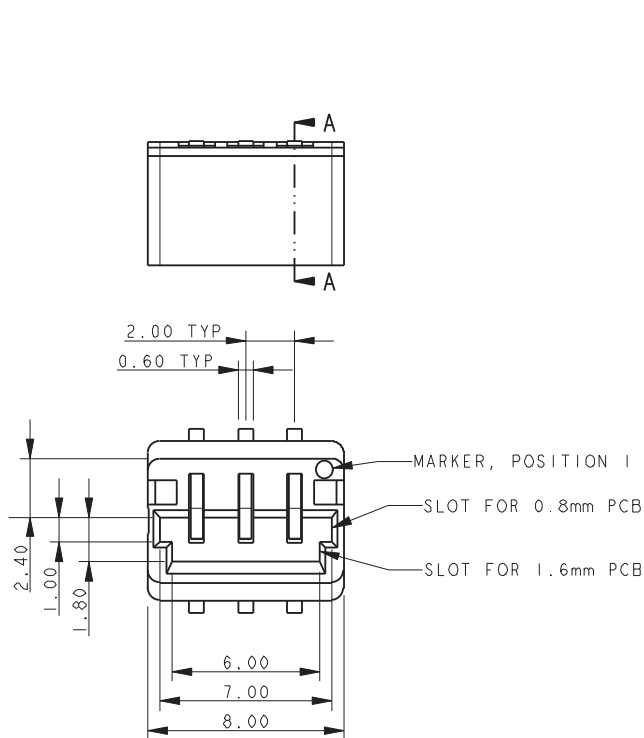

SECTION A-A

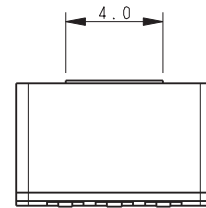

SUGGESTED PCB LAYOUT

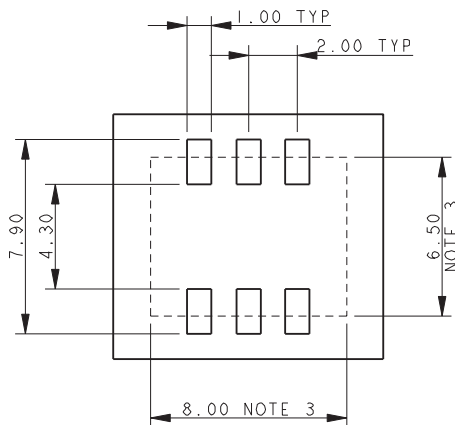

PICK AND PLACE TAPE
REMOVE AFTER SOLDERING

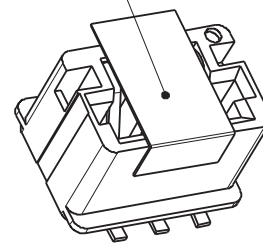

PACKING DETAILS

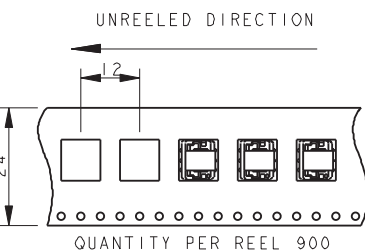
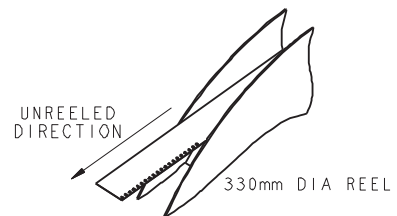

1. 5159-500 SERIES TOP MOUNTING EDGE CARD CONNECTOR, 3 WAY. FOR FURTHER DETAILS REFER TO PRODUCT SPECIFICATION 201-01-136 AND APPLICATION NOTES 201-01-137.
2. FOR MATING PCB EITHER 0.8MM OR 1.6MM THICK PCB. (DETAILS SAME AS 9159-500), REFER TO PAGE 98.
3. CONNECTOR OUTLINE.
4. ALL DIMENSIONS ± 0.20 UNLESS TOLERANCE SPECIFIED.
5. INSULATOR: PA4T, GLASS FILLED, HALOGEN FREE, UL94 V-0, COLOR REFER TO PAGE 92.
6. CONTACT: COPPER ALLOY, NICKEL PLATED WITH GOLD FLASH ON NOSE AND TIN ON TAILS.
7. BRACKET: COPPER ALLOY, PLATING, TIN OVER NICKEL.
8. PACKING IN TAPE AND REEL, 900 PIECES PER REEL.
9. CONTACT TAILS COPLINARITY WITHIN 0.10.
10. UL PRODUCT REFERENCE E90723 (US AND CANADA).

Vertical Top Entry Card Edge: 00-9159-BTB

4 Position

4 WAY TOP MOUNTING EDGE CARD CONNECTOR

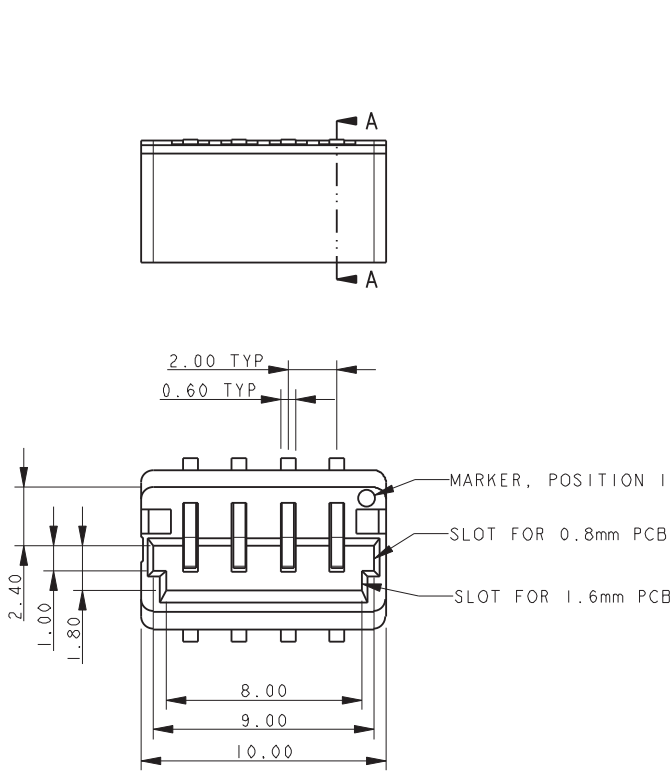

SUGGESTED PCB LAYOUT

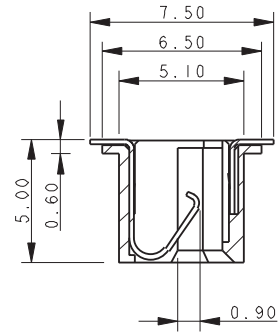
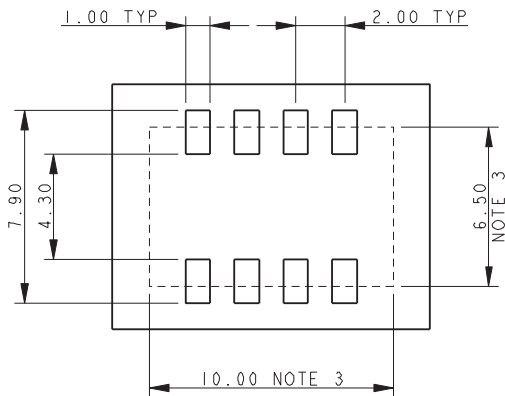

SECTION A-A

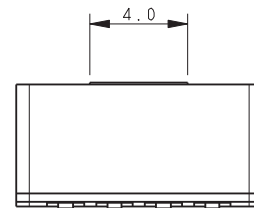

PICK AND PLACE TAPE
REMOVE AFTER SOLDERING

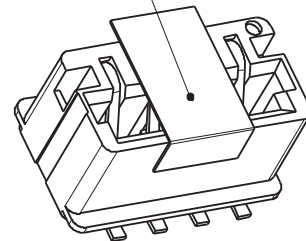

PACKING DETAILS

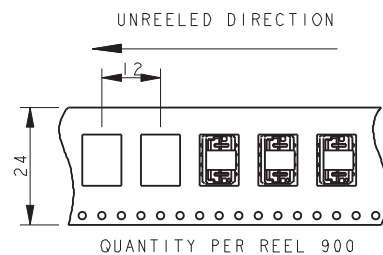
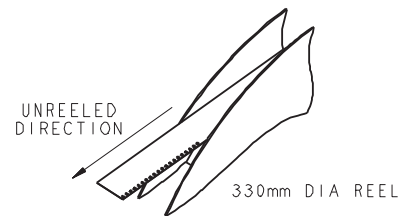

1. 5159-500 SERIES TOP MOUNTING EDGE CARD CONNECTOR, 1 WAY. FOR FURTHER DETAILS REFER TO PRODUCT SPECIFICATION 201-01-136 AND APPLICATION NOTES 201-01-137.
2. FOR MATING PCB EITHER 0.8MM OR 1.6MM THICK PCB. (DETAILS SAME AS 9159-500), REFER TO PAGE 98.
3. CONNECTOR OUTLINE.
4. ALL DIMENSIONS ± 0.20 UNLESS TOLERANCE SPECIFIED.
5. INSULATOR: PA4T, GLASS FILLED, HALOGEN FREE, UL94 V-0, COLOR REFER TO PAGE 92.
6. CONTACT: COPPER ALLOY, NICKEL PLATED WITH GOLD FLASH ON NOSE AND TIN ON TAILS.
7. BRACKET: COPPER ALLOY, PLATING, TIN OVER NICKEL.
8. PACKING IN TAPE AND REEL, 900 PIECES PER REEL. CONTACT TAILS COPLANARITY WITHIN 0.10.
9. UL PRODUCT REFERENCE E90723 (US AND CANADA).

Vertical Top Entry Card Edge: 00-9159-BTB

5 Position

5 WAY TOP MOUNTING EDGE CARD CONNECTOR

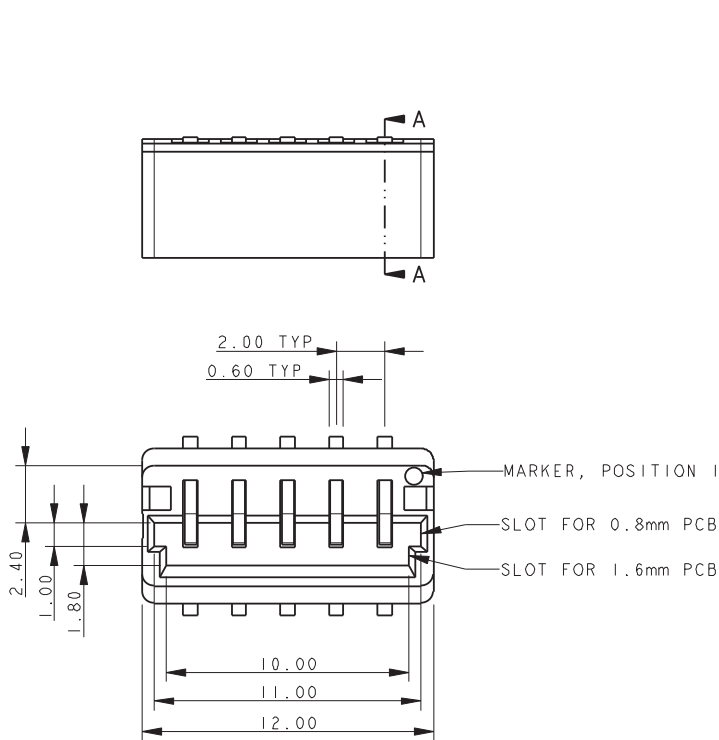

SUGGESTED PCB LAYOUT

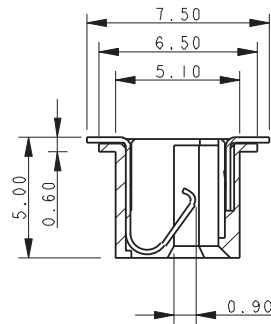
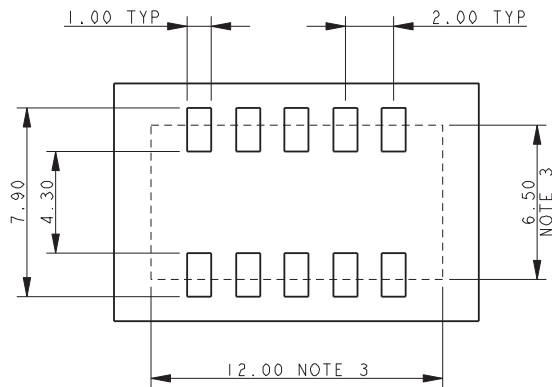

SECTION A-A

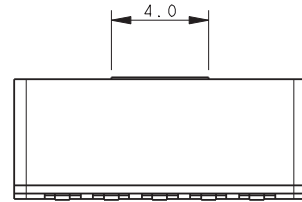

PICK AND PLACE TAPE
REMOVE AFTER SOLDERING

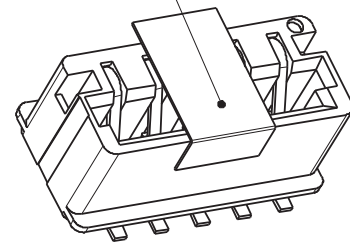

PACKING DETAILS

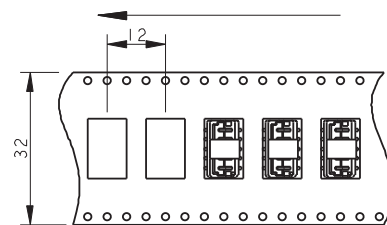
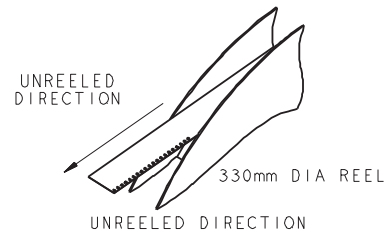

QUANTITY PER REEL 900

1. 5159-500 SERIES TOP MOUNTING EDGE CARD CONNECTOR, 5 WAY. FOR FURTHER DETAILS REFER TO PRODUCT SPECIFICATION 201-01-136 AND APPLICATION NOTES 201-01-137.
2. FOR MATING PCB EITHER 0.8MM OR 1.6MM THICK PCB. (DETAILS SAME AS 9159-500), REFER TO PAGE 98.
3. CONNECTOR OUTLINE.
4. ALL DIMENSIONS ± 0.20 UNLESS TOLERANCE SPECIFIED.
5. INSULATOR: PA4T, GLASS FILLED, HALOGEN FREE, UL94 V-0, COLOR REFER TO PAGE 92.
6. CONTACT: COPPER ALLOY, NICKEL PLATED WITH GOLD FLASH ON NOSE AND TIN ON TAILS.
7. BRACKET: COPPER ALLOY, PLATING, TIN OVER NICKEL.
8. PACKING IN TAPE AND REEL, 900 PIECES PER REEL.
9. CONTACT TAILS COPLANARITY WITHIN 0.10.
10. UL PRODUCT REFERENCE E90723 (US AND CANADA).

Vertical Top Entry Card Edge: 00-9159-BTB

6 Position

6 WAY TOP MOUNTING EDGE CARD CONNECTOR

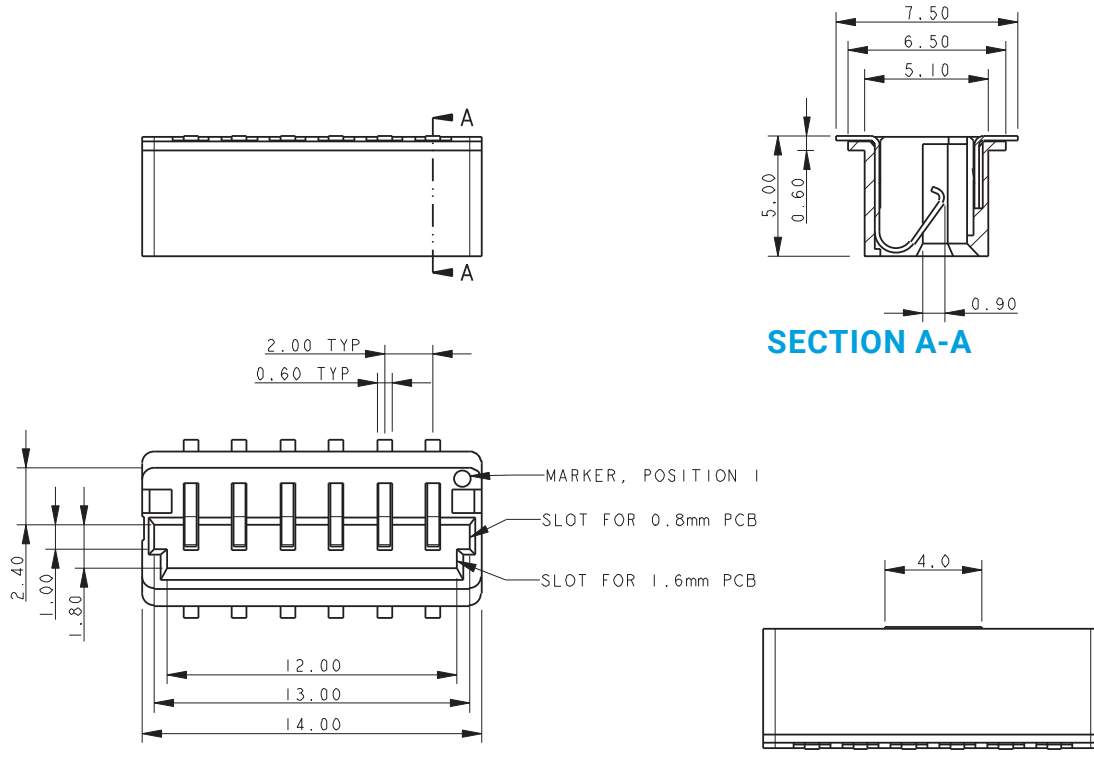

SUGGESTED PCB LAYOUT

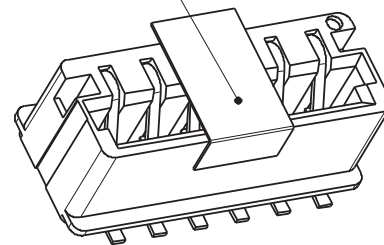
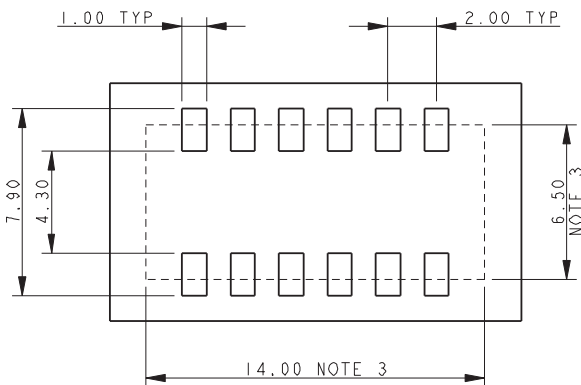

PACKING DETAILS

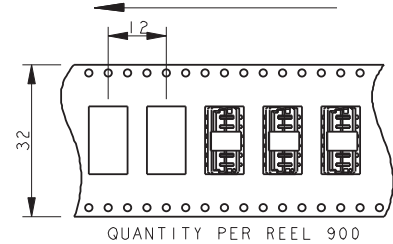
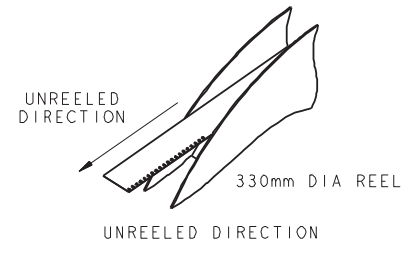

1. 5159-500 SERIES TOP MOUNTING EDGE CARD CONNECTOR, 6 WAY. FOR FURTHER DETAILS REFER TO PRODUCT SPECIFICATION 201-01-136 AND APPLICATION NOTES 201-01-137.
2. FOR MATING PCB EITHER 0.8MM OR 1.6MM THICK PCB. (DETAILS SAME AS 9159-500), REFER TO PAGE 98.
3. CONNECTOR OUTLINE.
4. ALL DIMENSIONS ± 0.20 UNLESS TOLERANCE SPECIFIED.
5. INSULATOR: PA4T, GLASS FILLED, HALOGEN FREE, UL94 V-0, COLOR REFER TO PAGE 92.
6. CONTACT: COPPER ALLOY, NICKEL PLATED WITH GOLD FLASH ON NOSE AND TIN ON TAILS.
7. BRACKET: COPPER ALLOY, PLATING, TIN OVER NICKEL.
8. PACKING IN TAPE AND REEL, 900 PIECES PER REEL.
9. CONTACT TAILS COPLANARITY WITHIN 0.10.
10. UL PRODUCT REFERENCE E90723 (US AND CANADA).

Vertical Top Entry Card Edge: 00-9159-BTB

Top Mounting Edge Card Connector – Mating PCB

TOP MOUNTING EDGE CARD CONNECTOR – MATING PCB

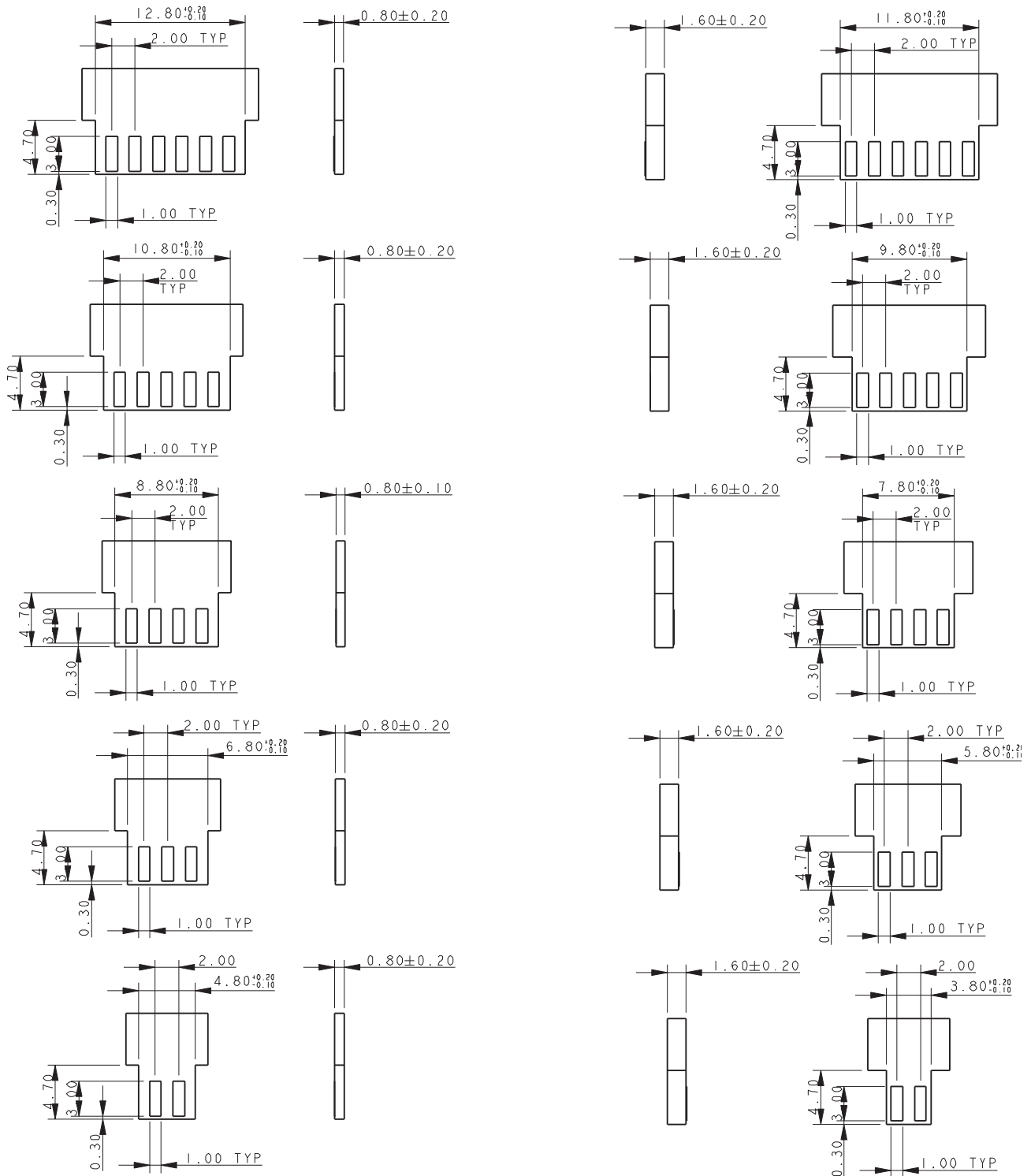

NOTES:

1. CORRECT DIMENSION FOR EITHER 0.80MM OR 1.60MM PCB THICKNESS MUST BE USED.
2. THICKNESS OF PCB INCLUDES ALL LAYERS INCLUDING COPPER AND PLATING.
3. PADS TO BE PLATED GOLD OVER NICKEL UNDERCOAT.
4. GENERAL TOLERANCE ± 0.10 UNLESS STATED.

Vertical Top Entry Card Edge: 00-9159-BTB

Assembly

TOP MOUNTING EDGE CARD CONNECTOR ASSEMBLY

CONNECTOR/PCB ASSEMBLY 0.8MM MATING PCB

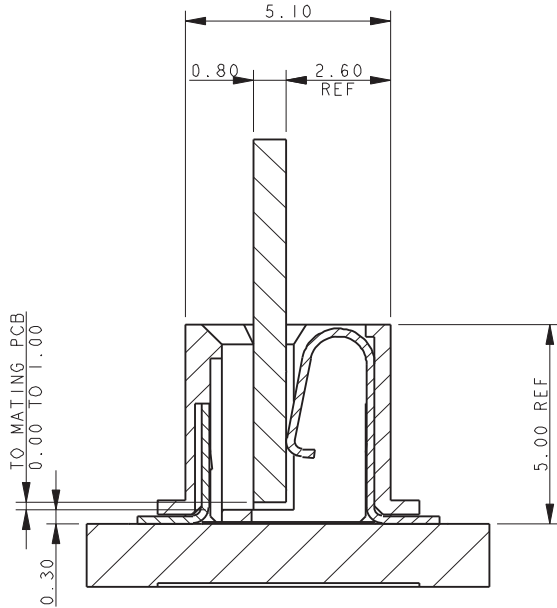

CONNECTOR/PCB ASSEMBLY

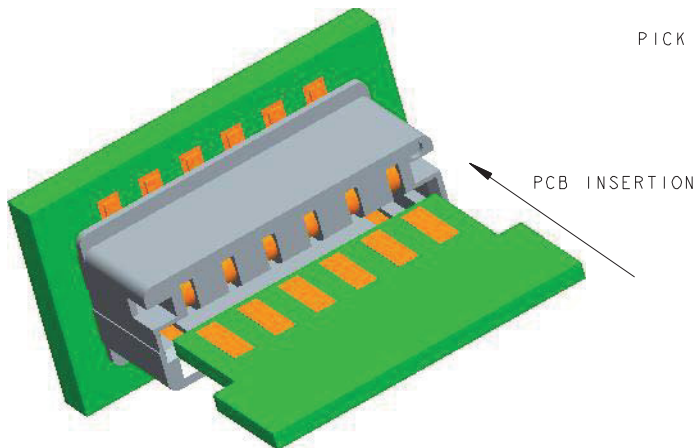
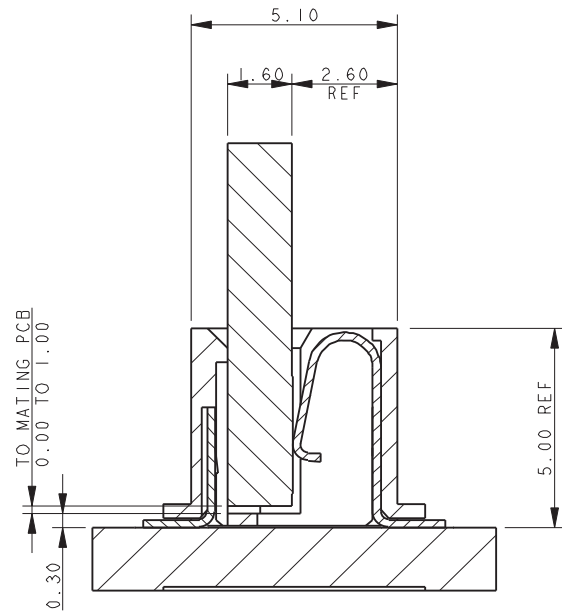

SUPPLIED WITH
PICK AND PLACE TAPE

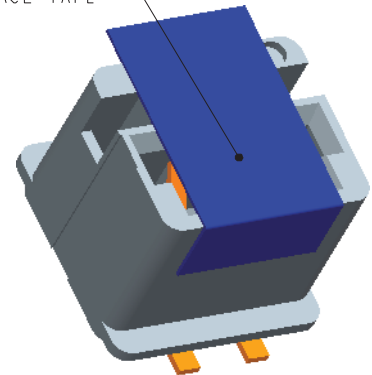

NOTES:

1. 9159-500 SERIES TOP MOUNTING EDGE CARD CONNECTOR.
2. FOR MATING PCB EITHER 0.8MM OR 1.6MM THICK. REFER TO PAGE 98 FOR MATING PCB DETAILS.
3. CONNECTOR SURFACE MOUNTING ON PCB.
4. PAD DETAILS ON THE MATING PCB ALLOW CONTACT TO BE MADE IN ANY POSITION FROM THE STOP FACE UP TO 1MM FROM THE STOP FACE.
5. GENERAL TOLERANCE ± 0.20 UNLESS STATED.

Vertical Dual Row Top Entry Card Edge

9159-650

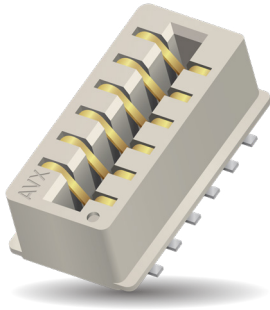

GENERAL DESCRIPTION

KYOCERA AVX Interconnect continues to develop unique connectors to fill the gap in the market. The newest addition to KYOCERA AVX's broadening line of one piece card edge connectors is the 4p-12p dual row top entry version 9159-650, which is extension of popular single row version 9159-550. This new configuration with staggered dual row contacts will allow doubled number of positions in similar size of the connector. Available in both without and with polarization where the mating PCB layout is modified to form a key, to avoid wrong insertion to the connector.

This small connector is packed with several key features that provide significant functionality in a broad range of applications. The proven contact system is gold plated for enhanced reliability, signal integrity and full 2.5A/contact current rating. The connector is designed for mating PCB board with 1.6mm thickness and gold plated pads.

APPLICATIONS

Provides a one piece connector solution for perpendicular PCB mating in applications:

- Automotive
- Industrial
- Lighting

FEATURES AND BENEFITS

- 2.5 Amps per contact current rating meets robust application requirements
- Doubled number of positions with dual row solution
- Optional kapton tape version supports pick and place robotic placement and SMT termination
- Available version with polarization where the mating PCB layout is modified to form a key, to avoid error during insertion
- Gold plated BeCu contact system for high reliability in harsh environments

ELECTRICAL

Current Rating	2.5 Amps / Contact
Voltage Rating	300 VAC

ENVIRONMENTAL

Operating Temperature	-40°C to +125°C
------------------------------	-----------------

MECHANICAL

Insulator Material	High temperature Nylon UL94V-0 rated
Contact Material	Beryllium Copper
Durability	10 Cycles
Plating	Gold / Tin over Nickel

HOW TO ORDER

Prefix 00 **Series** 9159 **No. of Ways** 0XX **65X** **9** **0** **6**

Plating Options
 6 = Gold plating on nose with Tin on Tails

Keying
 0 = without keying
 1 = with keying

Insulator Color

Code	Color	Application
9	White	UL Approved Standard

Double Sided Thru Board Card Edge
 651 = with Kapton Tape
 653 = without Kapton Tape

Code	Size	Contacts
004	2x2	4
006	2x3	6
008	2x4	8
010	2x5	10
012	2x6	12

Vertical Dual Row Top Entry Card Edge

9159-650

00 9159 0XX 65X 906

DIMENSIONS

Part Number	Size	Dim. A	Dim. B	Dim. C	Dim. D	Tape Width	Kapton Tape
00-9159-004-651-906	2 x 2	7.0	5.0	1.5	4.8	24	YES
00-9159-004-653-906							NO
00-9159-006-651-906	2 x 3	9.0	7.0	2.5	6.8	24	YES
00-9159-006-653-906							NO
00-9159-008-651-906	2 x 4	11.0	9.0	3.5	8.8	24	YES
00-9159-008-653-906							NO
00-9159-010-651-906	2 x 5	13.0	11.0	4.5	10.8	32	YES
00-9159-010-653-906							NO
00-9159-012-651-906	2 x 6	15.0	13.0	5.5	12.8	32	YES
00-9159-012-653-906							NO

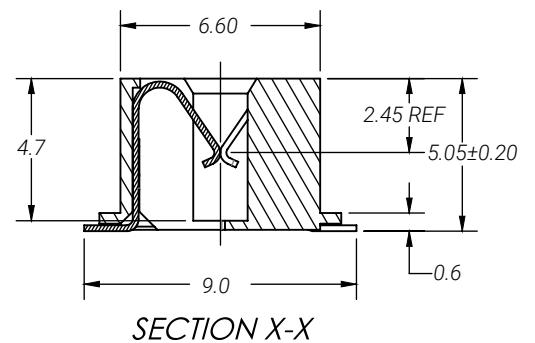
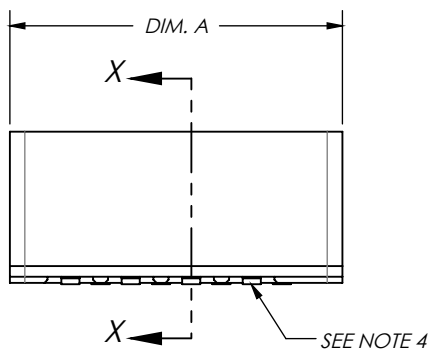
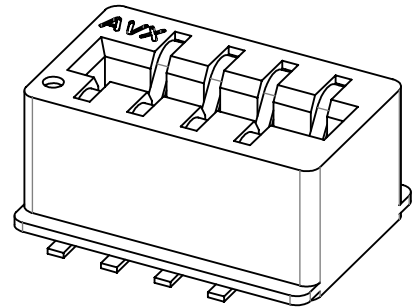
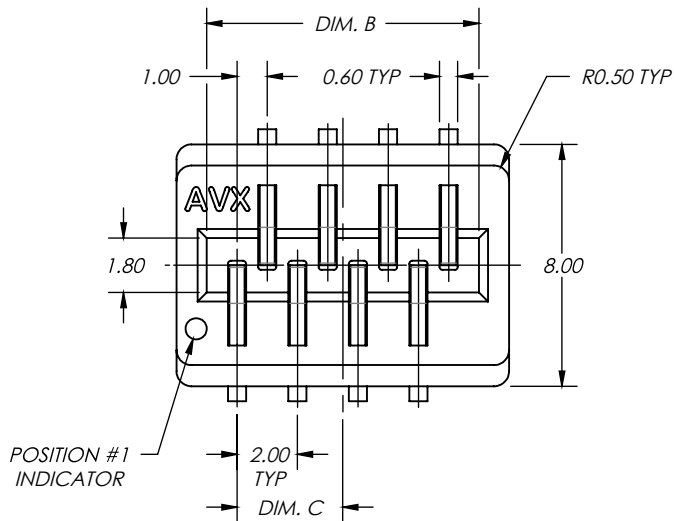

Vertical Dual Row Top Entry Card Edge

9159-650

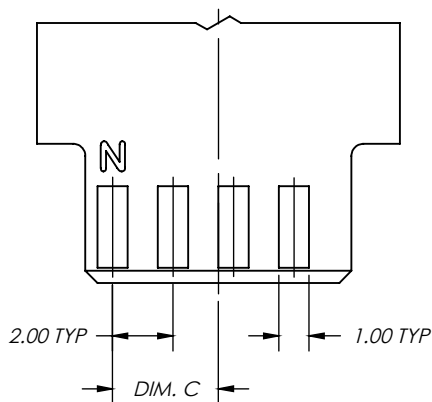
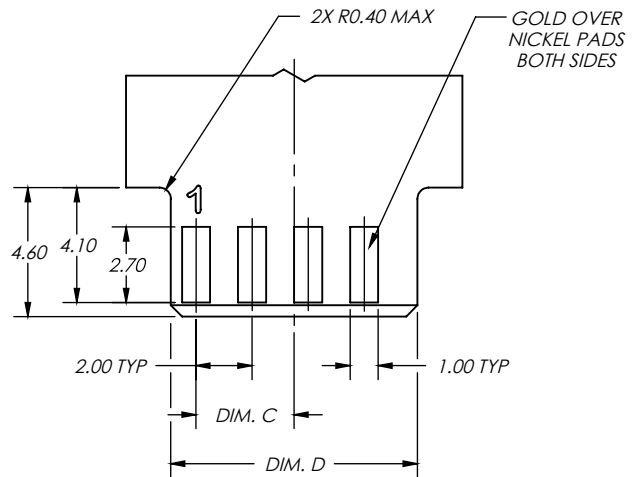
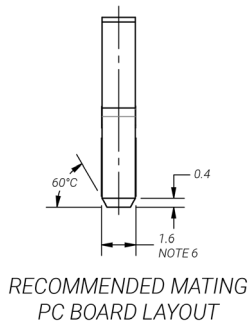
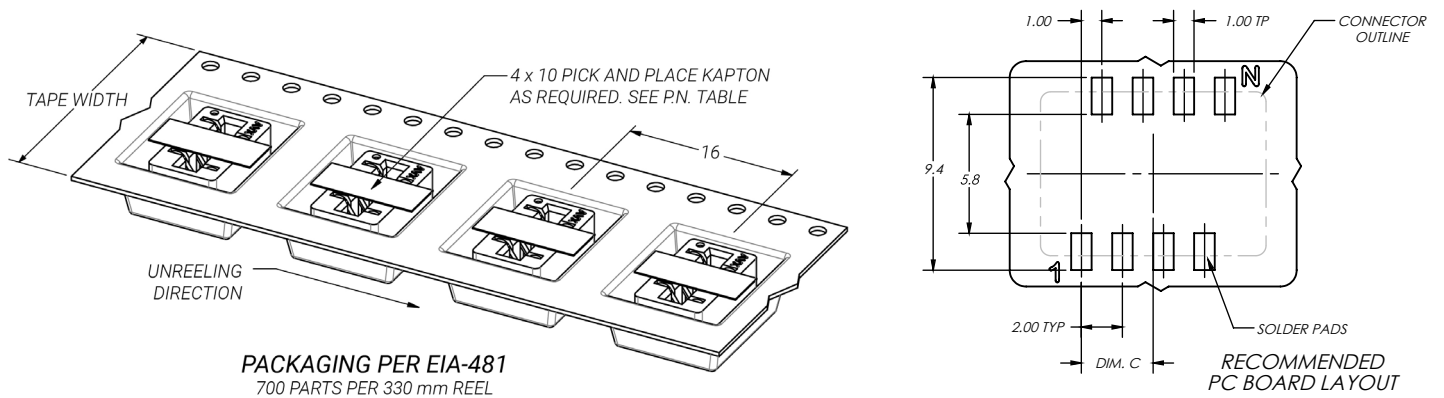

NOTES:

1. FOR FURTHER DETAILS, REFER TO KYOCERA AVX SPECIFICATION 20-01-226 AND APPLICATION NOTES 201-01-227.
2. HOUSING MATERIAL: GLASS-FILLED, HIGH TEMPERATURE NYLON; FLAME RETARDANT PER UL94V-0; COLOR: NATURAL.
3. CONTACT MATERIAL: HIGH STRENGTH COPPER ALLOY.
4. CONTACT PLATING: NICKEL UNDERPLATE ALL OVER; GOLD FLASH IN CONTACT AREA; LEAD-FREE MATTE TIN ON TAILS.
5. CONTACT TAIL CO-PLANARITY TO BE WITHIN 0.10 mm.
6. MATING PCB THICKNESS TO INCLUDE COPPER AND PLATING.
7. UL APPROVED (US AND CANADA) UL REFERENCE E90723.

Vertical Dual Row Top Entry Card Edge

9159-650

00 9159 0XX 65X 916

DIMENSIONS

Part Number	Size	Dim. A	Dim. B	Dim. C	Dim. D	Tape Width	Kapton Tape
00-9159-004-651-916	2 x 2	7.0	5.0	1.5	4.8	24	YES
NO							
00-9159-006-651-916	2 x 3	9.0	7.0	2.5	6.8	24	YES
NO							
00-9159-008-651-916	2 x 4	11.0	9.0	3.5	8.8	24	YES
NO							
00-9159-010-651-916	2 x 5	13.0	11.0	4.5	10.8	32	YES
NO							
00-9159-012-651-916	2 x 6	15.0	13.0	5.5	12.8	32	YES
NO							

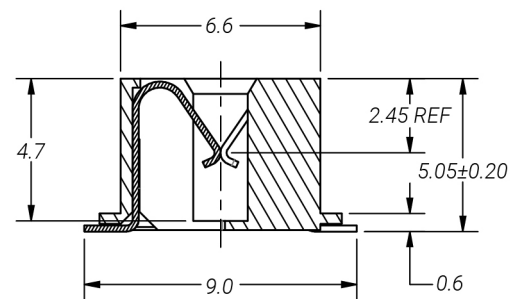
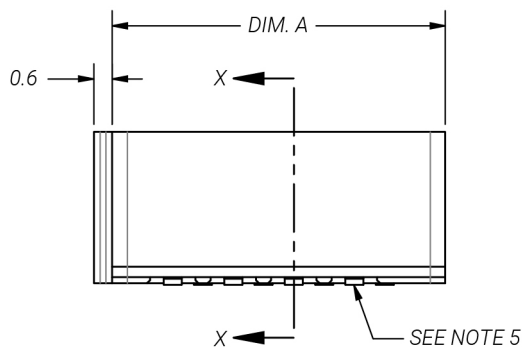
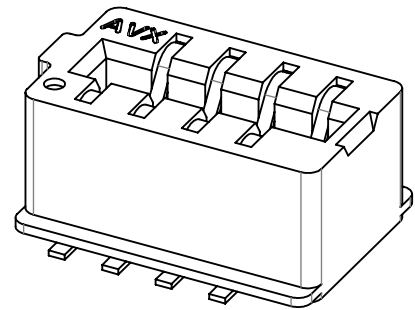
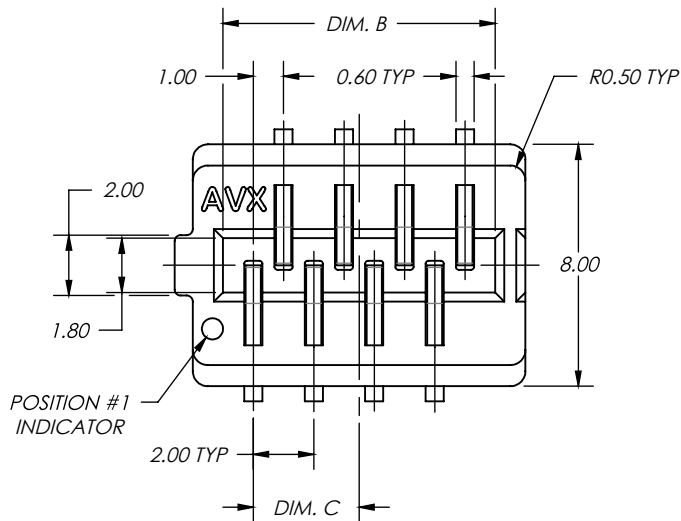

SECTION X-X

Vertical Dual Row Top Entry Card Edge

9159-650

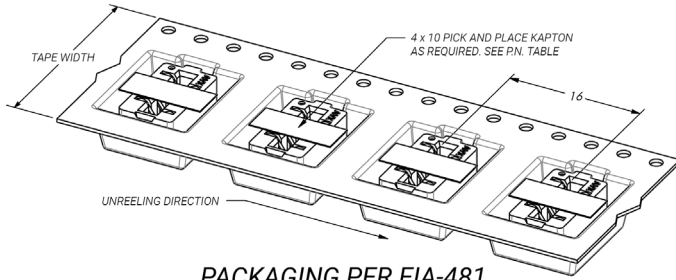

PACKAGING PER EIA-481
700 PARTS PER 330 mm REEL

RECOMMENDED PC BOARD LAYOUT

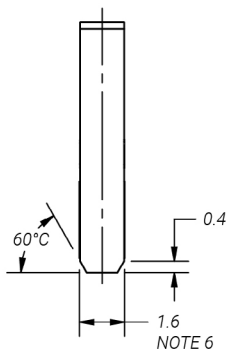
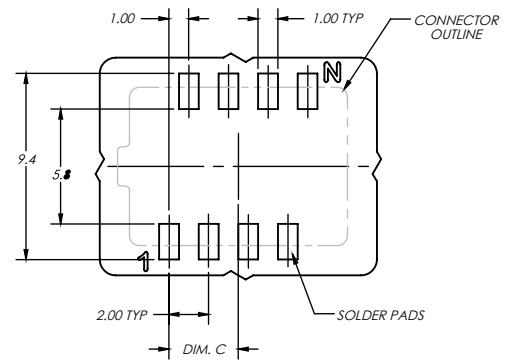

RECOMMENDED MATING
PC BOARD LAYOUT

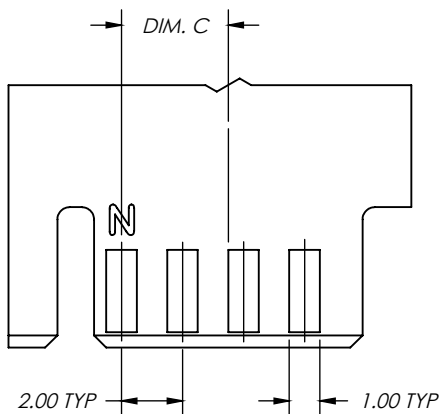
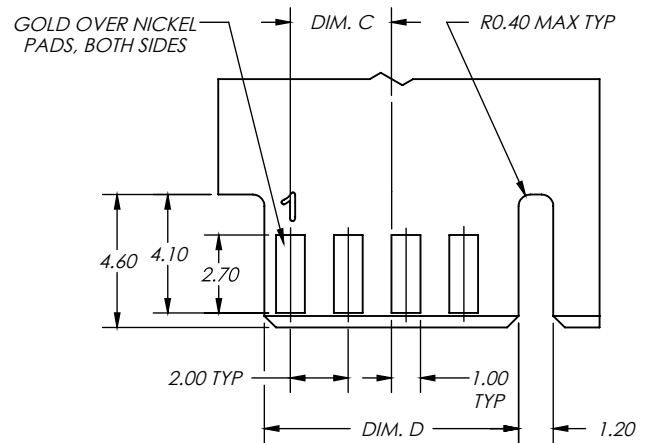

NOTES:

1. FOR FURTHER DETAILS, REFER TO KYOCERA AVX SPECIFICATION 201-01-226 AND APPLICATION NOTES 201-01-227.
2. HOUSING MATERIAL: GLASS-FILLED, HIGH TEMPERATURE NYLON; FLAME RETARDANT PER UL94V-0; COLOR: NATURAL.
3. CONTACT MATERIAL: HIGH STRENGTH COPPER ALLOY.
4. CONTACT PLATING: NICKEL UNDERPLATE ALL OVER; GOLD FLASH IN CONTACT AREA; LEAD-FREE MATTE TIN ON TAILS.
5. CONTACT TAIL CO-PLANARITY TO BE WITHIN 0.10 mm.
6. MATING PCB THICKNESS TO INCLUDE COPPER AND PLATING.
7. UL APPROVED (US AND CANADA); UL REFERENCE E90723.

Dual Row Inverted Thru Board Card Edge

9159-600

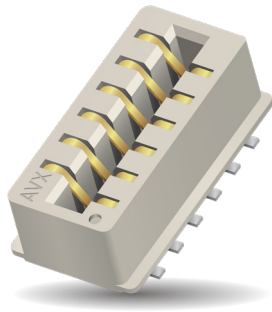

GENERAL DESCRIPTION

KYOCERA AVX Interconnect continues to develop unique connectors to fill the gap in the market. The newest addition to KYOCERA AVX's broadening line of one piece card edge connectors is the 4p-12p Dual Row Inverted version 9159-650, which is extension of popular single row version 9159-500. This new configuration with staggered dual row contacts will allow doubled number of positions in similar size of the connector.

This small connector is packed with several key features that provide significant functionality in a broad range of applications. The proven contact system is gold plated for enhanced reliability, signal integrity and full 2.5A/contact current rating. The connector is designed for mating PCB board with 1.6mm thickness and

gold plated pads.

APPLICATIONS

Provides a one piece connector solution for perpendicular PCB mating in applications:

- Automotive
- Industrial
- Lighting

FEATURES AND BENEFITS

- 2.5 Amps per contact current rating meets robust application requirements
- Doubled number of positions with dual row solution
- Gold plated BeCu contact system for high reliability in harsh environments
- Low profile thru board design does not interfere with Led's etc.

HOW TO ORDER

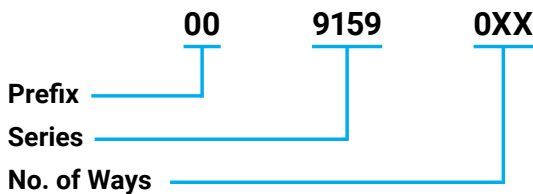

Code	Size	Contact
004	2x2	4
006	2x3	6
008	2x4	8
010	2x5	10
012	2x6	12

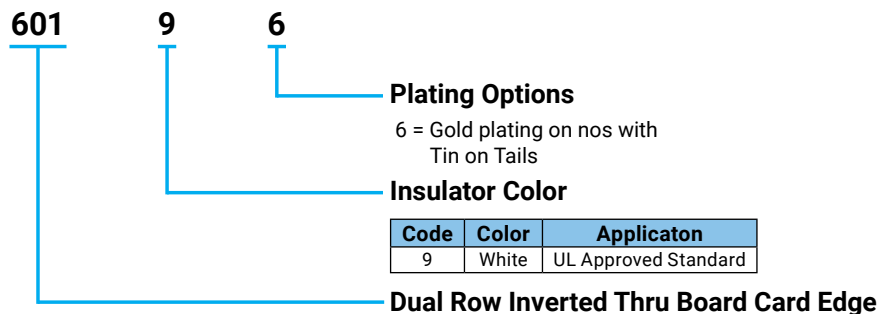

ELECTRICAL

Current Rating	2.5 Amps / Contact
Voltage Rating	300 VAC

ENVIRONMENTAL

Operating Temperature	-40°C to +125°C
-----------------------	-----------------

MECHANICAL

Insulator Material	High temperature Nylon UL94V-0 rated
Contact Material	Beryllium Copper
Durability	10 Cycles
Plating	Gold / Tin over Nickel

Dual Row Inverted Thru Board Card Edge

9159-600

00 9159 0XX 601 906

DIMENSIONS

Part Number	Size	Dim. A	Dim. B	Dim. C	Dim. D	Dim. E
00-9159-004-601-906	2 x 2	7.00	5.00	1.50	4.80	7.20
00-9159-006-601-906	2 x 3	9.00	7.00	2.50	6.80	9.20
00-9159-008-601-906	2 x 4	11.00	9.00	3.50	8.80	11.20
00-9159-010-601-906	2 x 5	13.00	11.00	4.50	10.80	13.20
00-9159-012-601-906	2 x 6	15.00	13.00	5.50	12.80	15.20

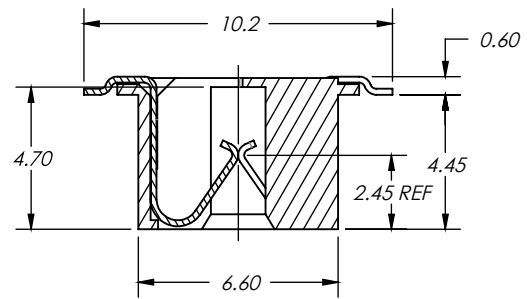
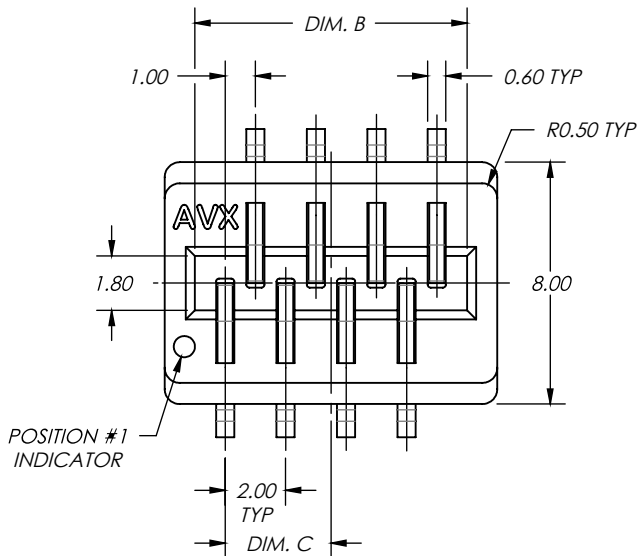
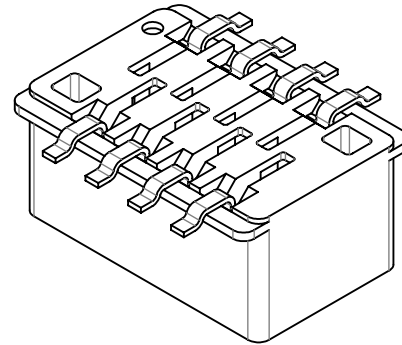
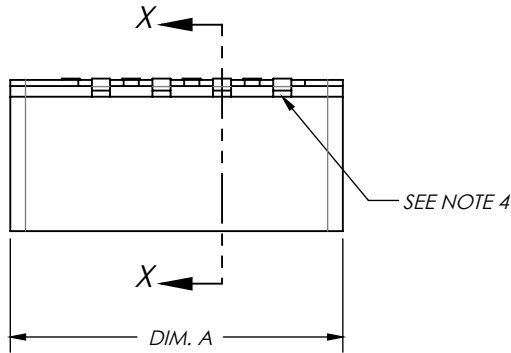
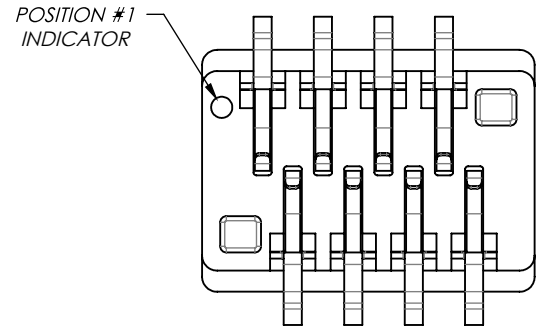

SECTION X-X

Dual Row Inverted Thru Board Card Edge

9159-600

00 9159 0XX 601 906

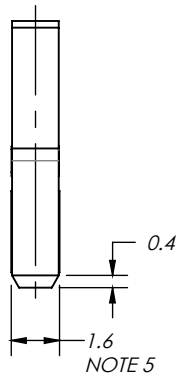
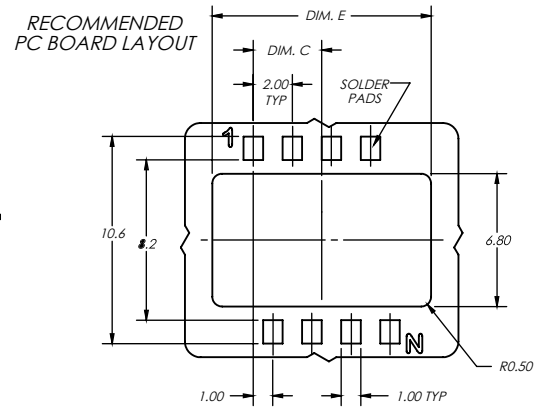
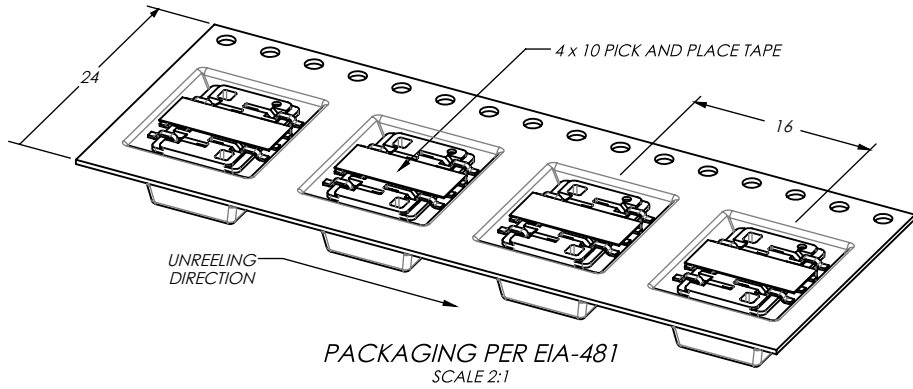

RECOMMENDED MATING PC BOARD LAYOUT

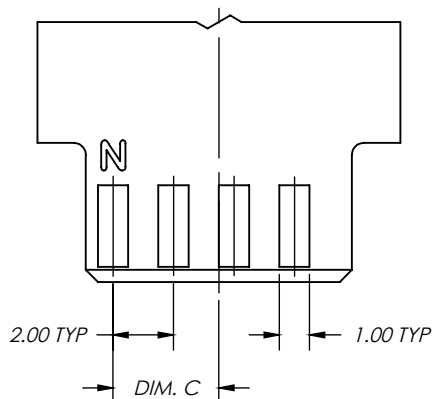
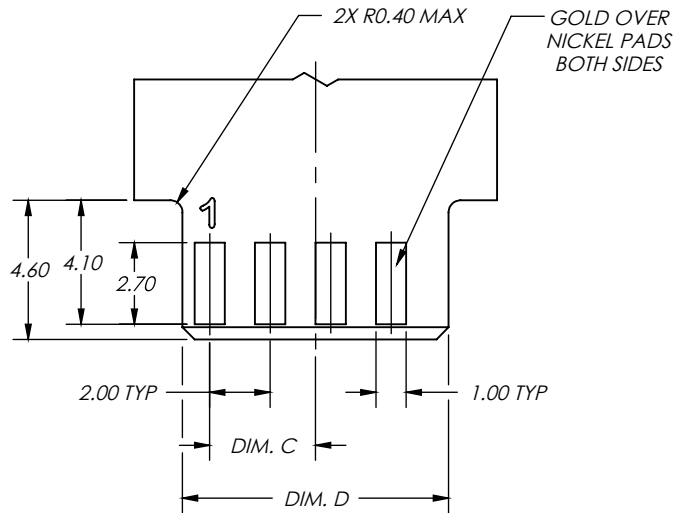

NOTES:

1. HOUSING MATERIAL: GLASS-FILLED, HIGH TEMPERATURE NYLON; FLAME RETARDANT PER UL94V-0; COLOR: NATURAL.
2. CONTACT MATERIAL: HIGH STRENGTH COPPER ALLOY.
3. CONTACT PLATING: NICKEL UNDERPLATE ALL OVER; GOLD FLASH IN CONTACT AREA; LEAD-FREE MATTE TIN ON TAILS.
4. CONTACT TAIL CO-PLANARITY TO BE WITHIN 0.10 mm.
5. MATING PCB THICKNESS TO INCLUDED COPPER AND PLATING.
6. PACKAGING TO BE IN POCKET TAPE ON REELS PER EIA-481 WITH 700 PARTS PER REEL.

Ultra-Low Profile 2.5mm Pitch Battery-9155-100

General Description



KYOCERA AVX has been leading the industry with reliable Board-to-Board (BTB) compression connectors for commercial, medical and harsh industrial applications, obtaining the very first contact patent in the early 1990's. The broad range of connectors offers both signal contacts which support 1 Amp/contact up to 40 position as well as low pin count (LPC) power contacts up to 3 Amps/contact.

The newest addition is the Ultra Low Profile (ULP) power connector that supports a 1.3mm compressed height, the lowest on the market. Gold plated Beryllium Copper (BeCu) contacts offers the most reliable and resilient contact performance in this miniature package. The sweeping contact design offers 0.7mm deflection range, long contact wipe and in excess of 40 grams of contact force at minimum operating deflection. All combined, this connector is rated at an unbelievable 5000 mating cycles for mechanical endurance.

APPLICATIONS

- Low profile power, signal, ground or shielding requirements
- Repeatable/Pluggable module or battery pack requirements
- Low profile flex circuit to PCB applications
- Portable devices

FEATURES AND BENEFITS

- High Reliability / High Cycle Life BeCu contacts for maximum system performance
- ULP 1.3mm minimum operating height with 0.7mm "Z" axis compression/ tolerance range
- Gold plating supports a broad range applications based on reliability and environments
- 3 Amp contact rating over a -40°C to +105°C operating range supports a broad application spectrum

ELECTRICAL

- Current Rating: 3 Amps/Contact
- Voltage Rating: 125VAC

ENVIRONMENTAL

- Operating Temperature: -40°C to +125°C

MECHANICAL

- Insulator Material: Glass-Filled Nylon 46; UL94 V-0
- Contact Material: Beryllium Copper
- Plating: Gold over Nickel
- Durability: 5000 Cycles

HOW TO ORDER

00	9155	00X
Prefix	Series	No. of Ways
		2 = 002
		3 = 003

10X
Low Profile
Battery Connector

Code	Description	Operating Height
100	Low Profile Battery Connector No Stop	1.30 (0.051)
101	Low Profile Battery Connector Stop	1.30 (0.051)

00X
Plating Option

Code	Description
006	0.4µm Selective Gold, Standard
008	0.8µm Selective Gold, Special Order



Ultra-Low Profile 2.5mm Pitch Battery-9155-100

2 Position – No Stop

2 WAY LOW PROFILE CONNECTOR NO STOP

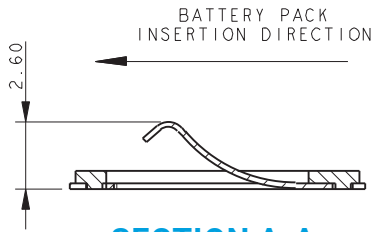

SECTION A-A

CONTACT UNDEFLECTED

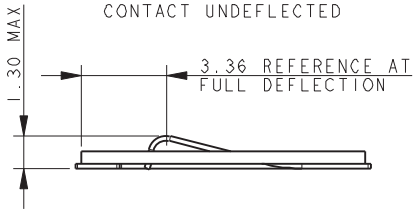

CONTACT SHOWN WITH STOP RESTING ON PCB

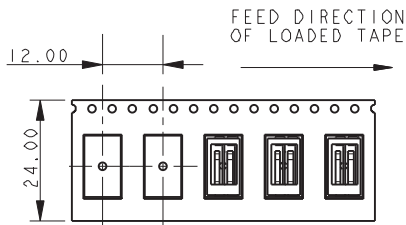
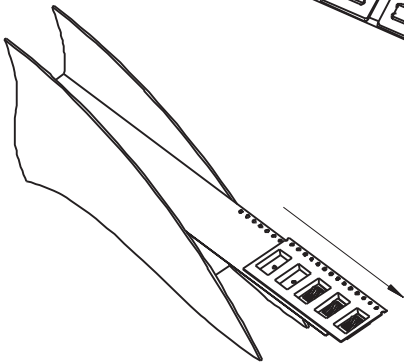
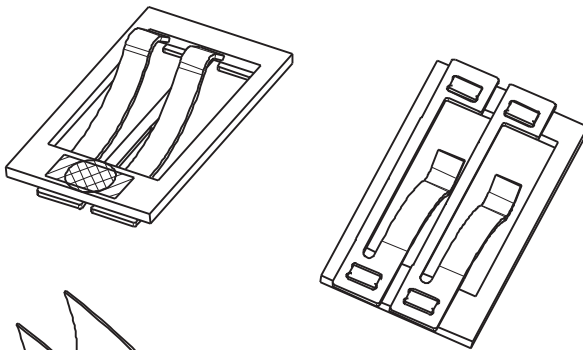

PACKING DETAILS

REEL QTY	1500
LEADER	500MM
TRAILER	500MM

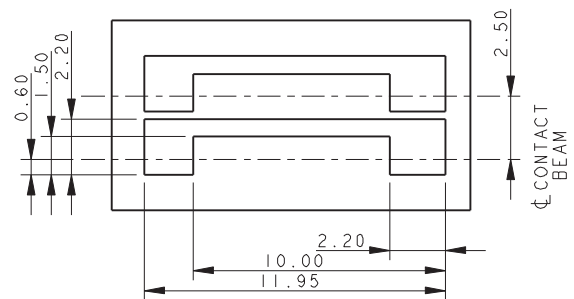
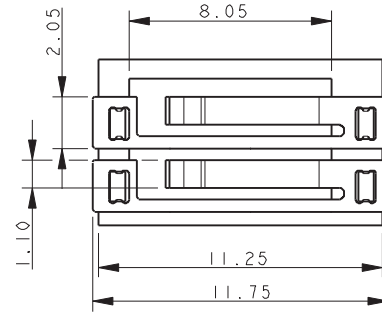
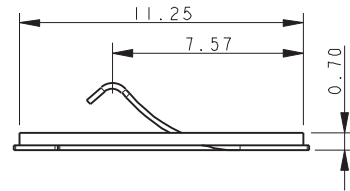
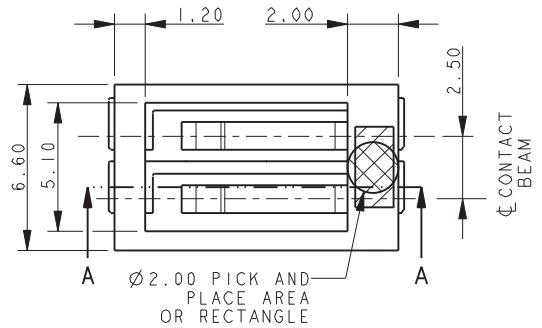

SUGGESTED PCB LAYOUT

NOTES:

1. FOR FULL PRODUCT SPECIFICATION REFER TO ELCO SPECIFICATION 201-01-094.
2. MATERIALS: CONTACT - COPPER ALLOY,
3. INSULATOR - GLASS FILLED NYLON. COLOR: BLACK.
4. TOLERANCE ± 0.20 UNLESS SPECIFIED.
5. PACKING DETAILS SEE TABLE.
6. FOR MATING PAD DETAILS REFER TO PAGE 105.

Ultra-Low Profile 2.5mm Pitch Battery-9155-100

3 Position – No Stop

3 WAY LOW PROFILE CONNECTOR NO STOP

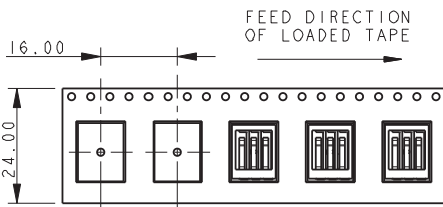
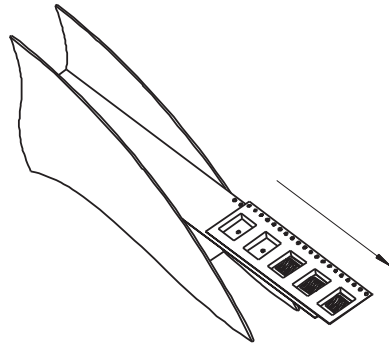
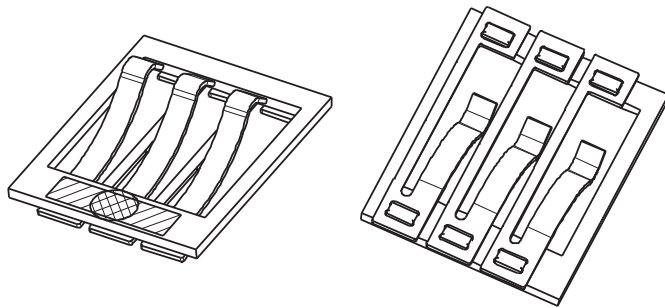
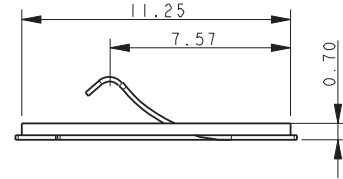
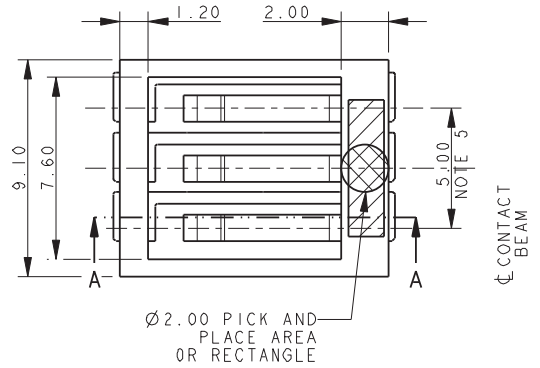
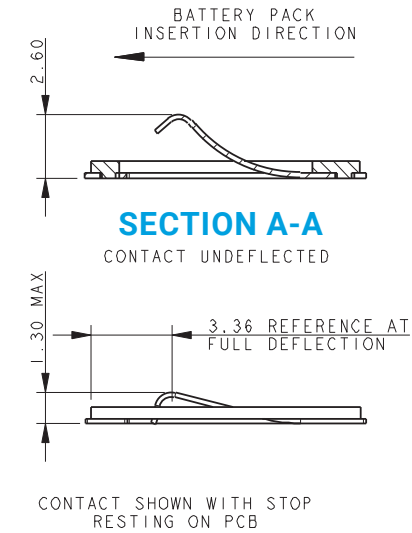

PACKING DETAILS

REEL QTY	1200
LEADER	500MM
TRAILER	500MM

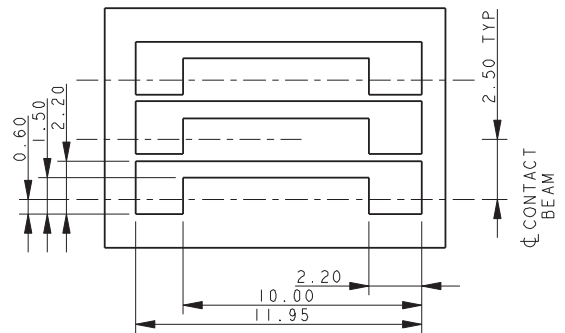
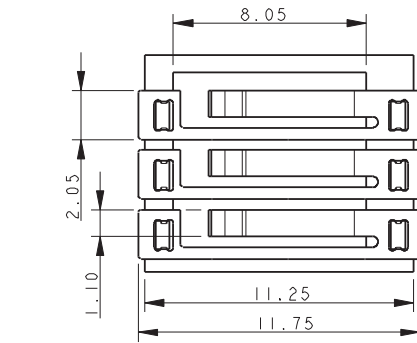

SUGGESTED PCB LAYOUT

NOTES:

1. FOR FULL PRODUCT SPECIFICATION REFER TO ELCO SPECIFICATION 201-01-094.
2. MATERIALS: CONTACT - COPPER ALLOY, INSULATOR - GLASS FILLED NYLON. COLOR: BLACK.
3. TOLERANCE ± 0.20 UNLESS SPECIFIED.
4. PACKING DETAILS SEE TABLE.
5. 2 EQUAL PITCHES @ 2.50 = 5.00.
6. FOR MATING PAD DETAILS REFER TO PAGE 105.

Ultra-Low Profile 2.5mm Pitch Battery-9155-100

2 Position – With Stop

2 WAY LOW PROFILE CONNECTOR WITH STOP

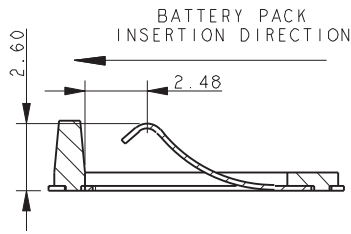

SECTION A-A

CONTACT UNDEFLECTED

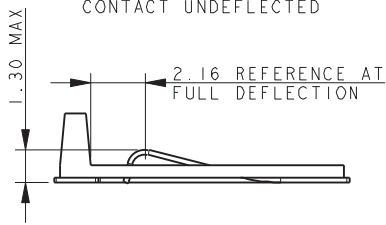

CONTACT SHOWN WITH STOP RESTING ON PCB

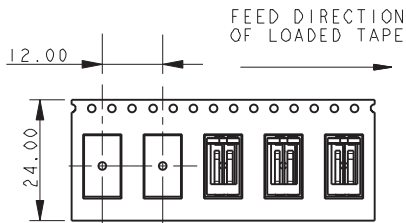
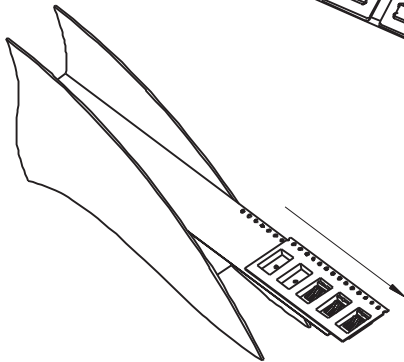
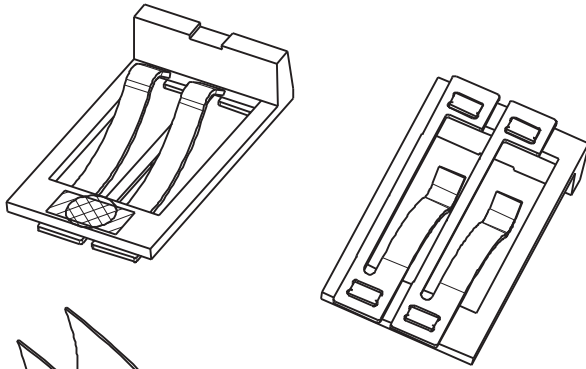

PACKING DETAILS

REEL QTY	1500
LEADER	500MM
TRAILER	500MM

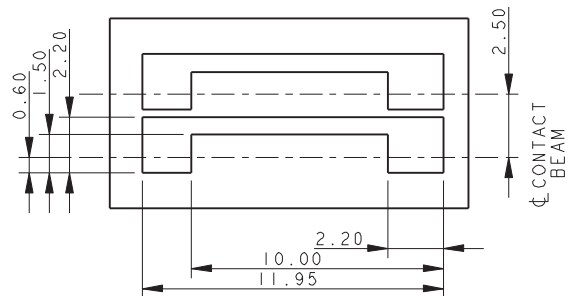
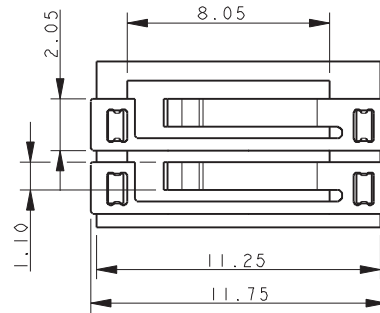
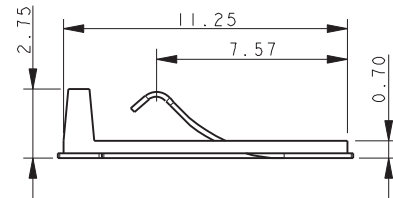
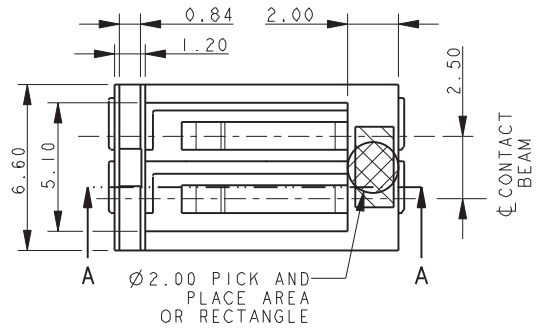

SUGGESTED PCB LAYOUT

NOTES:

1. FOR FULL PRODUCT SPECIFICATION REFER TO ELCO SPECIFICATION 201-01-094.
2. MATERIALS: CONTACT - COPPER ALLOY,
3. INSULATOR - GLASS FILLED NYLON. COLOR: BLACK.
4. TOLERANCE ± 0.20 UNLESS SPECIFIED.
5. PACKING DETAILS SEE TABLE.
6. FOR MATING PAD DETAILS REFER TO PAGE 105.

Ultra-Low Profile 2.5mm Pitch Battery-9155-100

3 Position – With Stop

3 WAY LOW PROFILE CONNECTOR WITH STOP

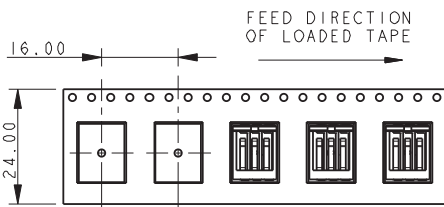
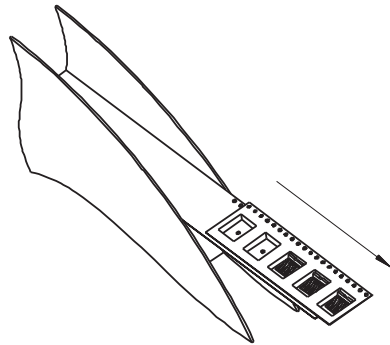
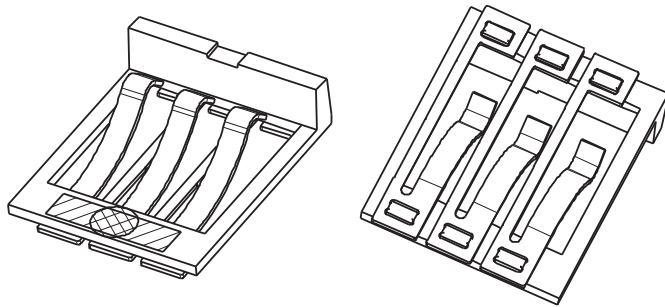
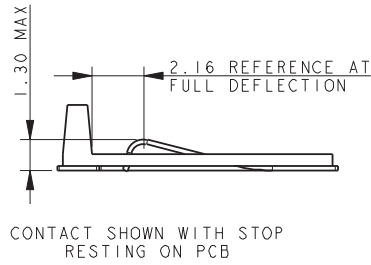
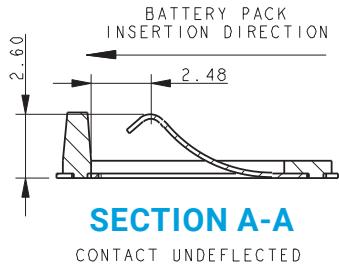

PACKING DETAILS

REEL QTY	1200
LEADER	500MM
TRAILER	500MM

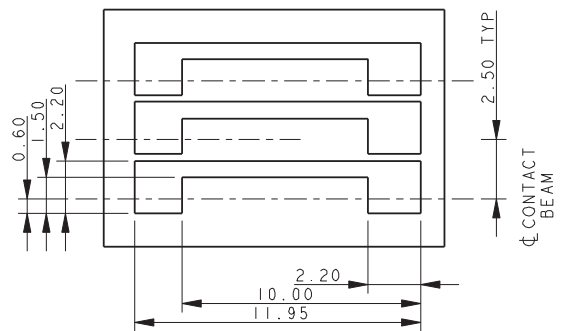
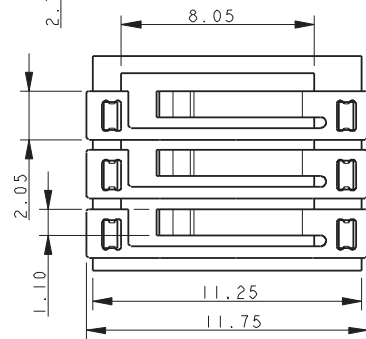
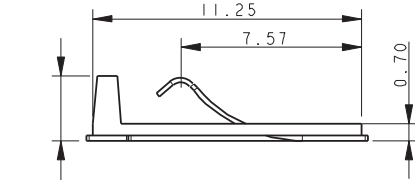
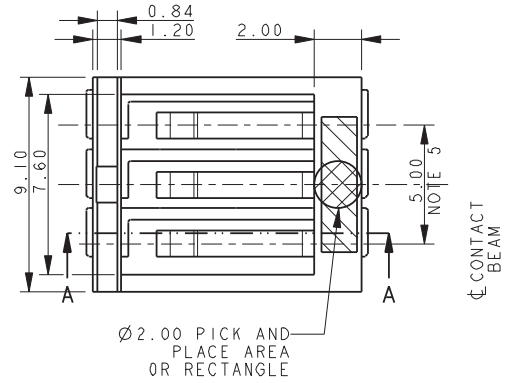

SUGGESTED PCB LAYOUT

NOTES:

1. FOR FULL PRODUCT SPECIFICATION REFER TO ELCO SPECIFICATION 201-01-094.
2. MATERIALS: CONTACT - COPPER ALLOY, INSULATOR - GLASS FILLED NYLON. COLOR: BLACK.
3. TOLERANCE ± 0.20 UNLESS SPECIFIED.
4. PACKING DETAILS SEE TABLE.
5. 2 EQUAL PITCHES @ 2.50 = 5.00.
6. FOR MATING PAD DETAILS REFER TO PAGE 105.

Ultra-Low Profile 2.5mm Pitch Battery-9155-100

Low Profile Mating Pads

LOW PROFILE MATING PADS

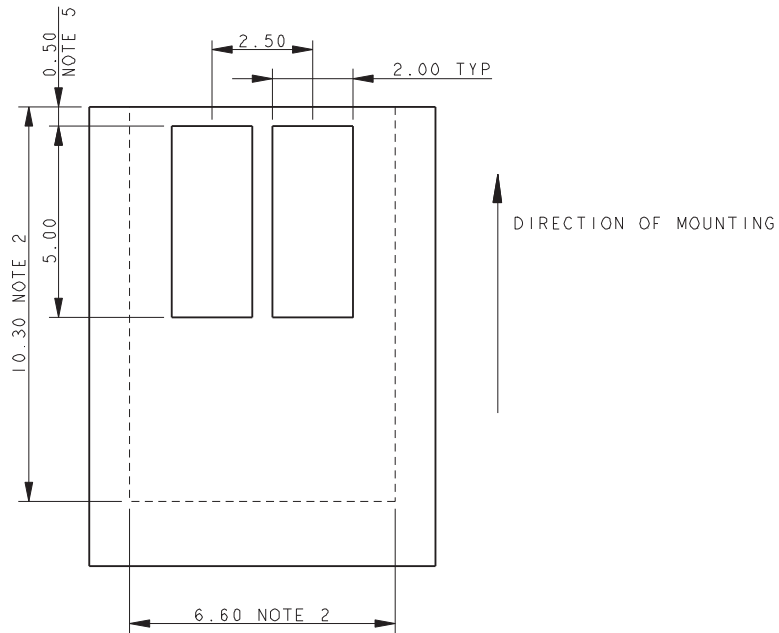

2 WAY MATING PADS

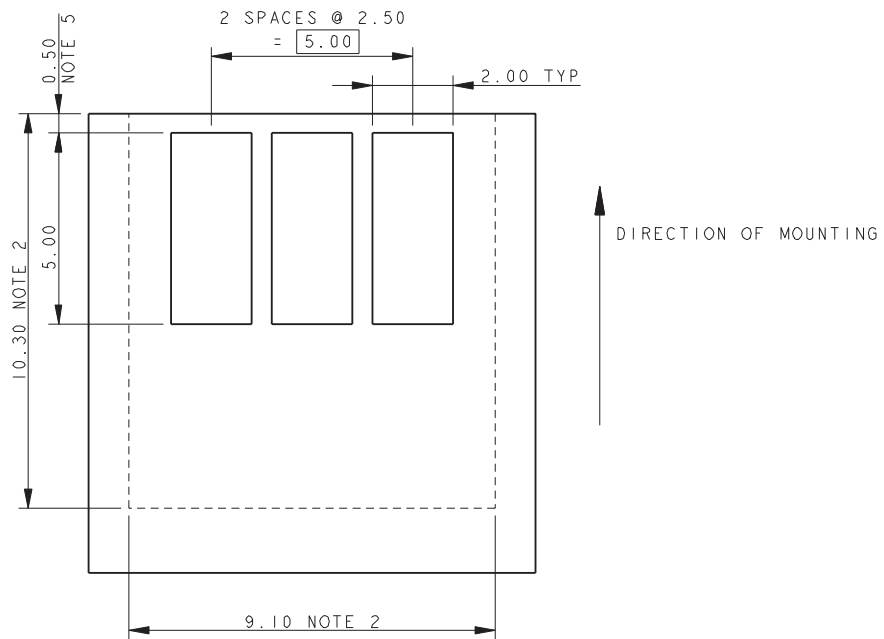

3 WAY MATING PADS

NOTES:

1. SUGGESTED MATING PADS FOR LOW PROFILE BATTERY CONNECTORS.
2. OUTLIE OF CONNECTOR.
3. PROFERED PLATING ON PADS GOLD OVER NICKEL.
4. REFERENCE DIMENSIONS.
5. DIMENSION TO EDGE OF BOARD FOR CONNECTORS WITH STOP.

Low Profile Single Contact-70-9155

General Description



Designers for ruggedized connectors to meet harsh environments continue to look for new products which will reduce size and cost without jeopardizing performance. The new Ultra-Low Profile (ULP) compression contact from KYOCERA AVX surface mounts to a PCB and provides a reliable compression connection to the mating board, even under extreme shock and vibration applications. With over 20 years of 1-Piece compression contact experience, this innovative contact offers full connector performance functionality at the individual contact level. Thus, allowing single contacts to be placed in any location or position on a PCB.

The high force beryllium copper contact is gold plated to maximize reliability and signal integrity. The current offering has two contacts with nominal heights of 1.0mm and 1.5mm. Add in the "Z" axis tolerance range and the compressed height covers 0.75mm up to 1.75mm. The contacts are supplied in tape and reel for easy SMT placement.

APPLICATIONS

- Industrial/Ruggedized handheld or portable devices
- BTB connection for any traditional power or signal application
- Ground connections between PCB's or housings

FEATURES AND BENEFITS

- Reliable gold plated Beryllium Copper contacts for high cycle life and signal integrity up to 1000 cycles
- Tape and reel packaged for automated SMT placement
- Sweeping beam design for pluggable/module applications
- Three gold plating options to match end product environmental or expected life requirements

ELECTRICAL

- Current Rating: 3 Amps
- Voltage Rating: UL 300V
Based on placement distance

ENVIRONMENTAL

- Operating Temperature: -40°C to +125°C

MECHANICAL

- Contact Material: Beryllium Copper
- Contact Plating: Gold over Nickel
- Durability: 50, 500 and 1000 cycles

HOW TO ORDER



61X

Contact Description

Code	Nominal Operating Height	Contact Operating Height Range
610	1.00mm	0.75mm to 1.25mm
615	1.50mm	1.25mm to 1.75mm

00X

Contact Description

Code	Gold Thickness	Description	Availability
004	0.1µm	Nickel under Plate, Gold on Nose Tin on Remainder	Standard
006	0.4µm	Nickel under Plate, Gold on Nose Tin on Remainder	Special Order
008	0.8µm	Nickel under Plate, Gold on Nose Tin on Remainder	Special Order

Certification: UL File #E90723



Low Profile Single Contact-70-9155

Height 1.00mm

70-9155-001-610-006 NOMINAL WORKING HEIGHT 1.00MM

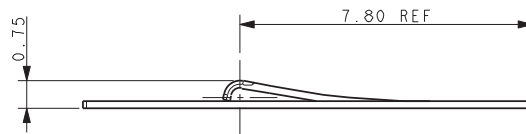
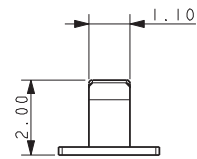
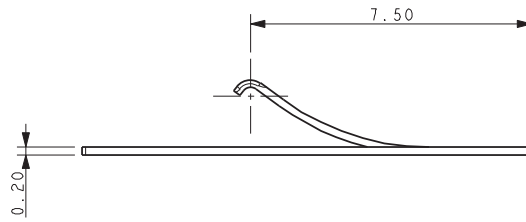
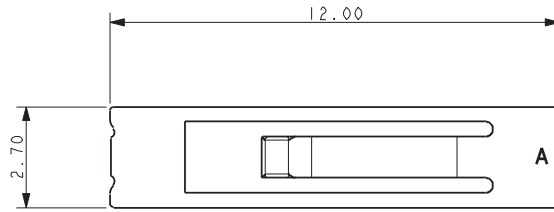

FULLY DEFLECTED CONTACT

SUGGESTED MATING PCB LAYOUT

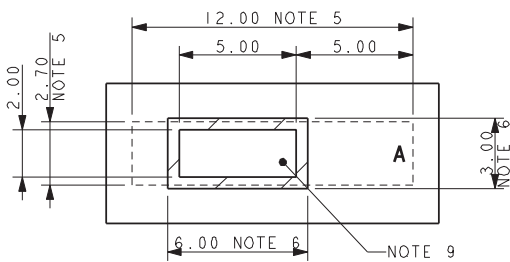

NOTES:

1. 9155 LOW PROFILE CONTACT, WORKING HEIGHT 0.75MM TO 1.25MM.
2. FOR FULL DETAILS REFER TO PRODUCT SPECIFICATION 201-01-153 AND APPLICATIONS NOTES 201-01-154.
3. MATERIAL: COPPER ALLOY 0.2MM THICK.
4. PLATING: NICKEL ALL OVER WITH GOLD ON CONTACT NOSE AND TIN ON THE REMAINDER. PARTS TO BE PACKED IN TAPE AND REEL. QTY PER REEL 3000.
5. OUTLINE OF CONNECTOR, ORIENTATION END "A".
6. AREA TO BE KEPT FREE OF SOLDER RESIST, FURTHER INFORMATION IN APPLICATION NOTES.
7. AREA BETWEEN PADS TO BE KEPT CLEAR OF TRACKS AND COMPONENTS.
8. SMT PADS PLATED TIN.
9. MATING PAD PLATED GOLD OVER NICKEL.

SUGGESTED SMT PCB LAYOUT

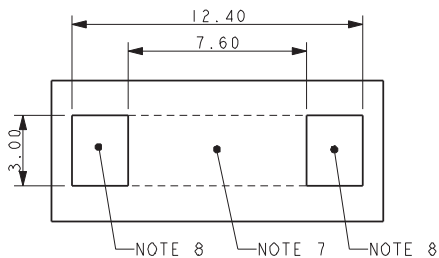

PACKING DETAILS

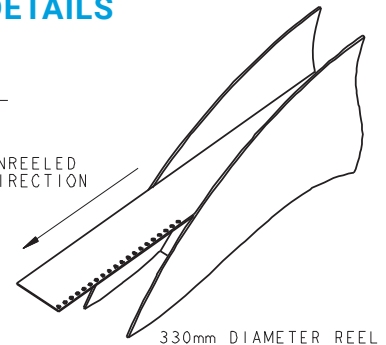
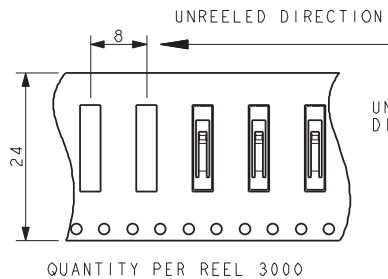

Low Profile Single Contact-70-9155

Height 1.50mm

70-9155-001-610-006 NOMINAL WORKING HEIGHT 1.50MM

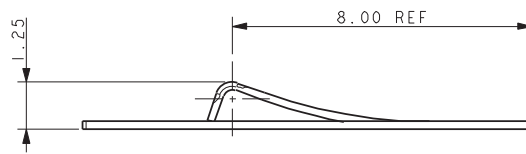
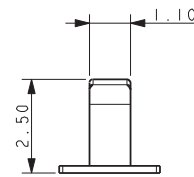
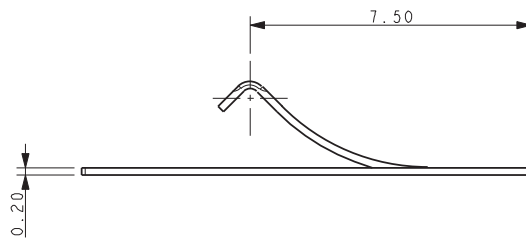
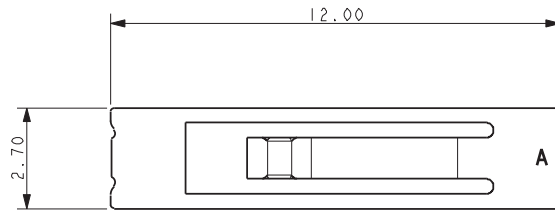

FULLY DEFLECTED CONTACT

SUGGESTED MATING PCB LAYOUT

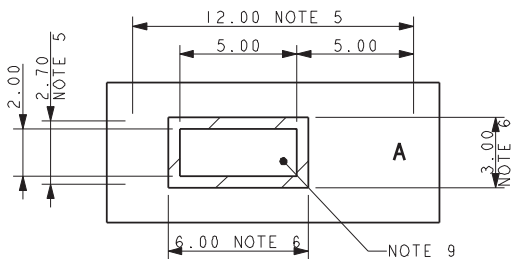

NOTES:

1. 9155 LOW PROFILE CONTACT, WORKING HEIGHT 0.75MM TO 1.25MM.
2. FOR FULL DETAILS REFER TO PRODUCT SPECIFICATION 201-01-153 AND APPLICATIONS NOTES 201-01-154.
3. MATERIAL: COPPER ALLOY 0.2MM THICK.
4. PLATING: NICKEL ALL OVER WITH GOLD ON CONTACT NOSE AND TIN ON THE REMAINDER. PARTS TO BE PACKED IN TAPE AND REEL. QTY PER REEL 3000.
5. OUTLINE OF CONNECTOR, ORIENTATION END "A".
6. AREA TO BE KEPT FREE OF SOLDER RESIST, FURTHER INFORMATION IN APPLICATION NOTES.
7. AREA BETWEEN PADS TO BE KEPT CLEAR OF TRACKS AND COMPONENTS.
8. SMT PADS PLATED TIN.
9. MATING PAD PLATED GOLD OVER NICKEL.

SUGGESTED SMT PCB LAYOUT

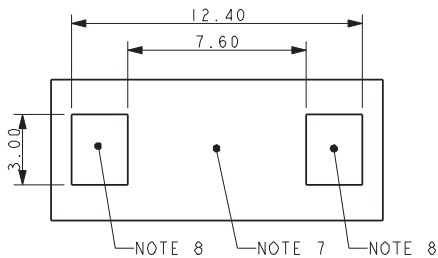

PACKING DETAILS

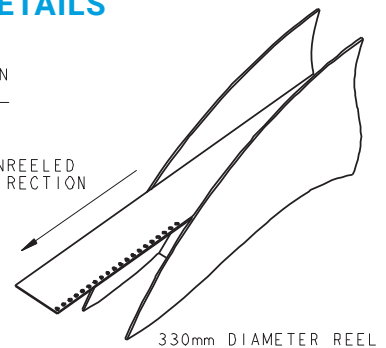
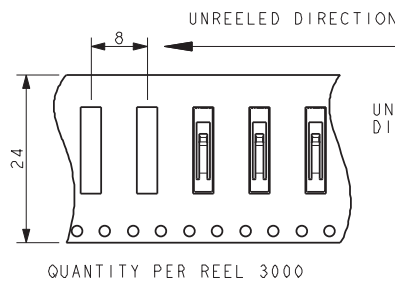

Dual Row Stacker: BTB-00-9158

General Description

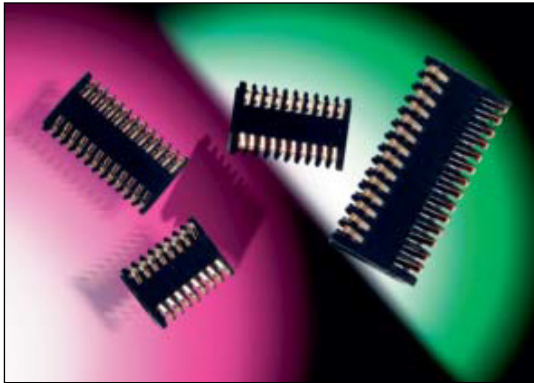

The MOBO® series 9158 is a one-piece connector used to connect two PCBs within mobile phones, pagers, PDAs, security, handheld scanners, etc. in a cost-effective manner.

A standard range is available with 16, 20, 24 and 28 contacts to suit stack heights of 1.90mm to 3.30mm. Other contact variants are also available up to 5.10mm, in custom housings. The SOLO STACKER can allow a spacing tolerance of up to $\pm 0.30\text{mm}$ and still provide reliable connections between the PCBs, even if they are not parallel.

SOLO STACKER is designed for PCB surface mounting and is supplied in tape and reel packaging. Gold plated pads on the mating PCB or suitable flex circuits provide connection between the boards.

Whatever your requirements this SOLO STACKER can also be customized to suit your applications.

APPLICATIONS

- Mobile Phones
- PDA
- Medical
- PMR
- Industrial
- Security
- Handheld Scanner

FEATURES AND BENEFITS

- Reduced assembly time.
- Only one part to purchase and stock.
- Due to the unique contact design, the mating device does not have to be parallel.
- Extremely robust when subjected to shock and vibration.
- Cost effective.
- Helps reduce tolerance accumulation within system.

ELECTRICAL

- Current Rating: 1 Amp/Contact
- Voltage Rating: 125V
Based on placement distance

ENVIRONMENTAL

- Operating Temperature:
-55°C to +125°C

MECHANICAL

- Insulator Material: High Temperature Plastic; UL94 HB
- Contact Material: Beryllium Copper
- Plating: Gold over Nickel
- Durability: 50 Cycles

HOW TO ORDER

00
Prefix

9158
Series

0XX
Number of Ways
016 = 16
020 = 20
024 = 24
028 = 28

0XX
Stack Height
020 = 1.9mm to 2.1mm
025 = 2.1mm to 2.7mm
030 = 2.8mm to 3.3mm

06
Plating Variation
06 = Selective Gold 0.25 μm
Gold Plated Contact
Nose Pure Tin Tail

X
PCB Location Bosses
1 = With PCB Location Bosses
2 = Without PCB Location Bosses



Dual Row Stacker: 00-9158-BTB

2.0mm Without Bosses

2.0MM DUAL ROW STACKER WITHOUT BOSSES

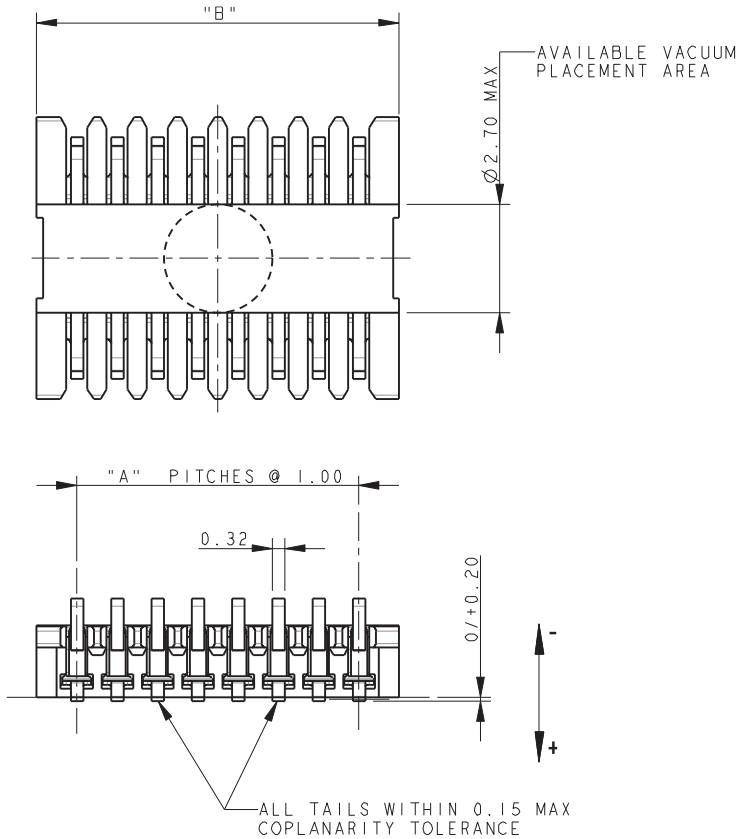

MATING CONDITION

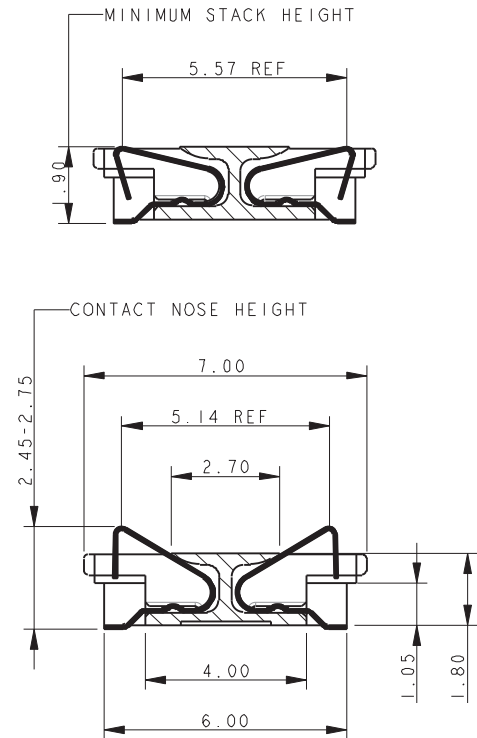

NOTES:

1. LAYOUT FOR MULTI-WAY DUAL ROW STACKING CONNECTOR (ELCO SERIES 9158).
2. FOR FULL PRODUCT SPECIFICATION REFER TO ELCO SPEC 201-01-073.
3. PART TO BE PACKED IN TAPE AND REEL. REFER TO PAGE 116 FOR DETAILS.
4. STACKER DESIGN TO ACCOMMODATE A PCB STACKING HEIGHT OF 1.90MM TO 2.10MM.
5. NO ALLOWANCE HAS BEEN MADE FOR SOLDER PASTE THICKNESS IN PCB STACKING HEIGHT.
6. GENERAL TOLERANCE ± 0.20 UNLESS OTHERWISE STATED.

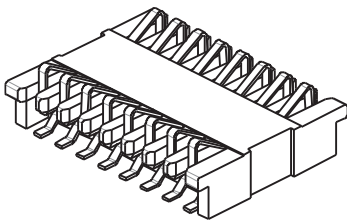

No of Positions	Part Number	A	B
16	00-9158-016-020-062	7	9.00
20	00-9158-020-020-062	9	11.00
24	00-9158-024-020-062	11	13.00
28	00-9158-028-020-062	13	15.00

SMT PCB FOOTPRINT

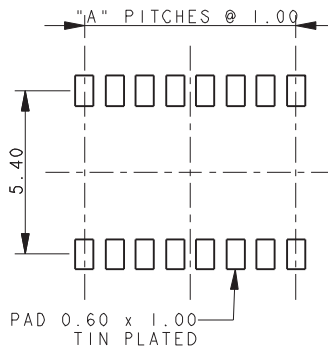

MATING PCB FOOTPRINT

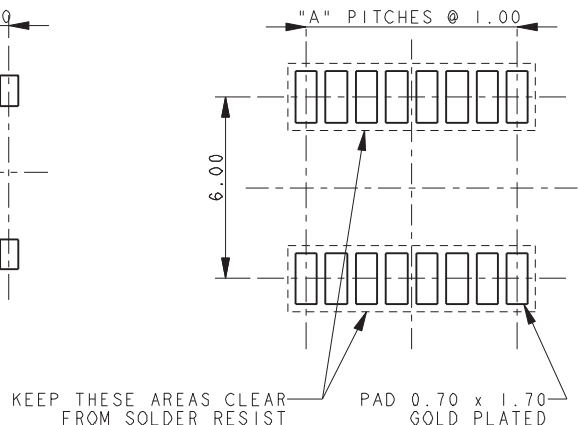

Dual Row Stacker: 00-9158-BTB

2.5mm Without Bosses

2.5MM DUAL ROW STACKER WITHOUT BOSSES

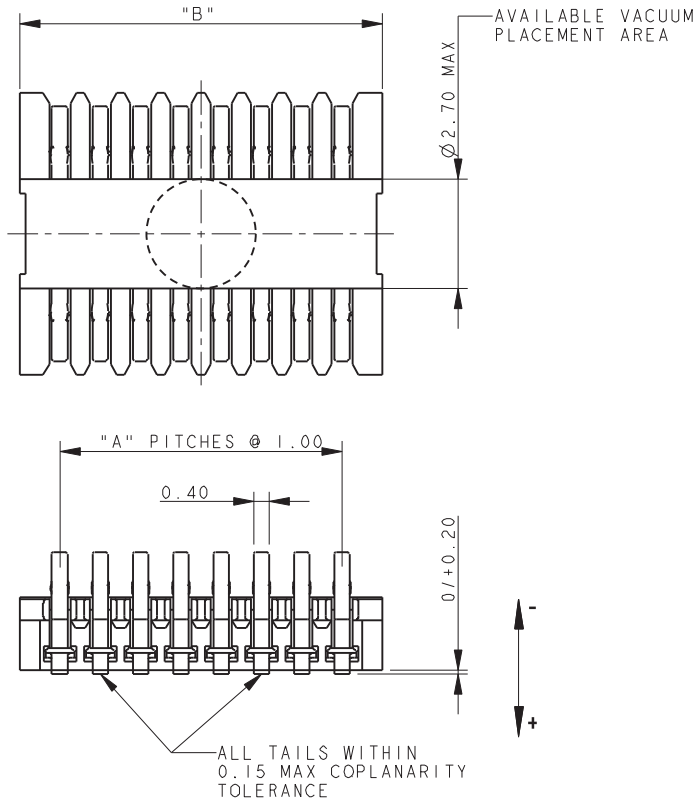

MATING CONDITION

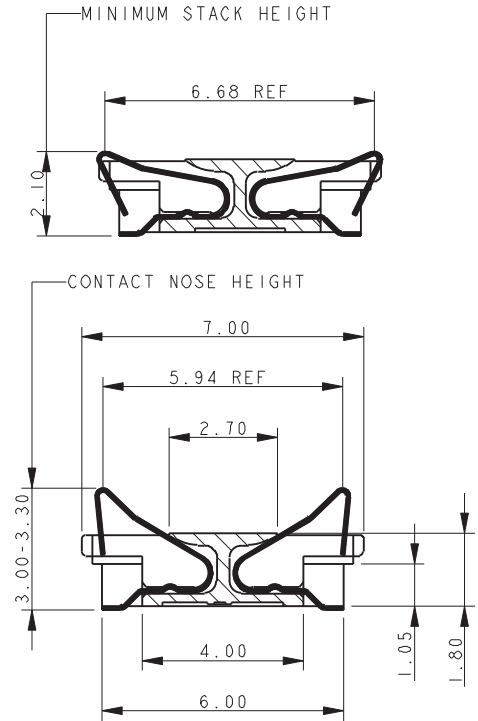

NOTES:

1. LAYOUT FOR MULTI-WAY DUAL ROW STACKING CONNECTOR (ELCO SERIES 9158).
2. FOR FULL PRODUCT SPECIFICATION REFER TO ELCO SPEC 201-01-073.
3. PART TO BE PACKED IN TAPE AND REEL. REFER TO PAGE 116 FOR DETAILS.
4. STACKER DESIGN TO ACCOMMODATE A PCB STACKING HEIGHT OF 2.10MM TO 2.70MM.
5. NO ALLOWANCE HAS BEEN MADE FOR SOLDER PASTE THICKNESS IN PCB STACKING HEIGHT.
6. GENERAL TOLERANCE ± 0.20 UNLESS OTHERWISE STATED.

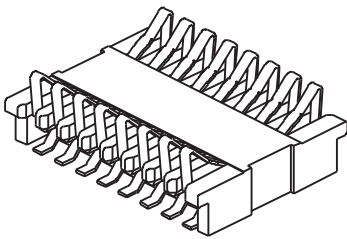

SMT PCB FOOTPRINT

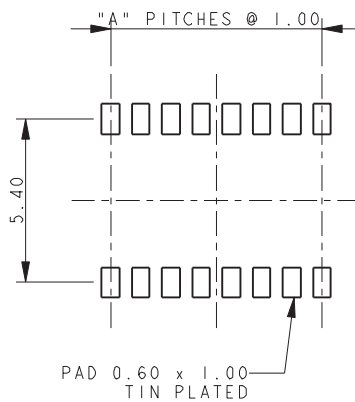

MATING PCB FOOTPRINT

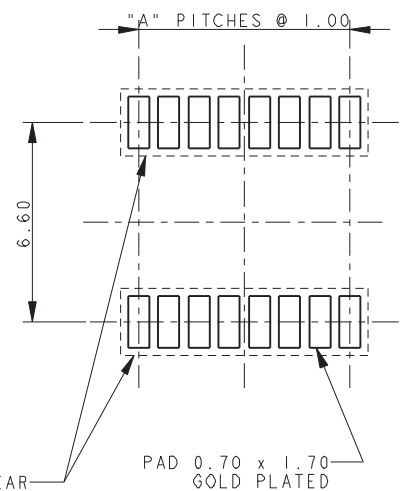

No of Positions	Part Number	A	B
16	00-9158-016-020-062	7	9.00
20	00-9158-020-020-062	9	11.00
24	00-9158-024-020-062	11	13.00
28	00-9158-028-020-062	13	15.00

Dual Row Stacker: 00-9158-BTB

3.0mm Without Bosses

3.0MM DUAL ROW STACKER WITHOUT BOSSES

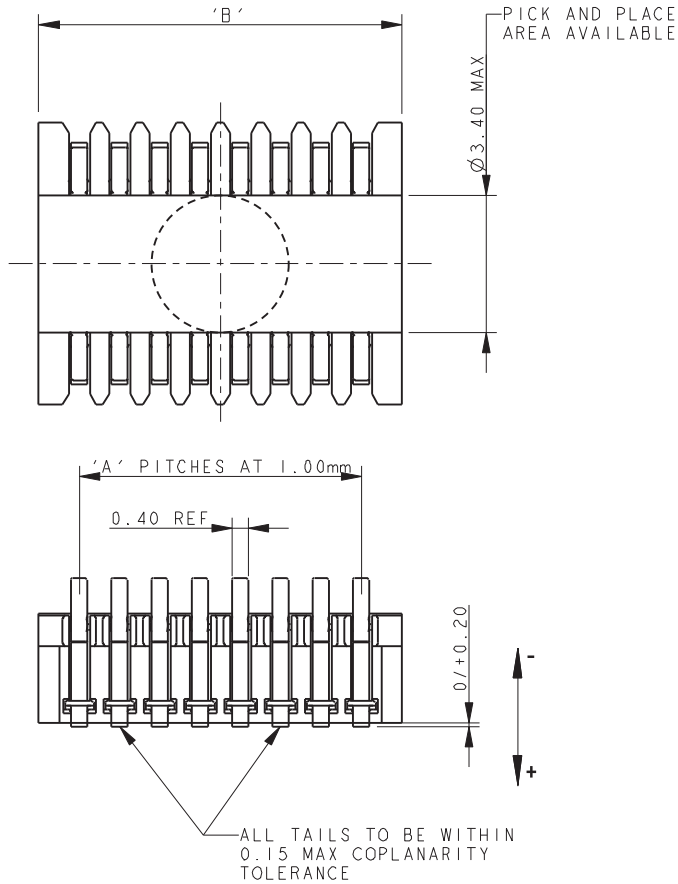

MATING CONDITION

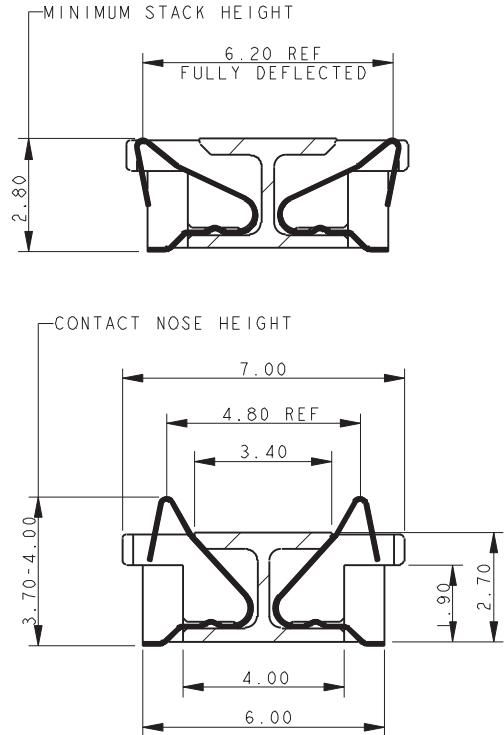

NOTES:

- LAYOUT FOR MULTI-WAY DUAL ROW STACKING CONNECTOR (ELCO SERIES 9158).
- FOR FULL PRODUCT SPECIFICATION REFER TO ELCO SPEC 201-01-073.
- PART TO BE PACKED IN TAPE AND REEL. REFER TO PAGE 116 FOR DETAILS.
- STACKER DESIGN TO ACCOMMODATE A PCB STACKING HEIGHT OF 2.80MM TO 3.30MM.
- NO ALLOWANCE HAS BEEN MADE FOR SOLDER PASTE THICKNESS IN PCB STACKING HEIGHT.
- GENERAL TOLERANCE ± 0.20 UNLESS OTHERWISE STATED.

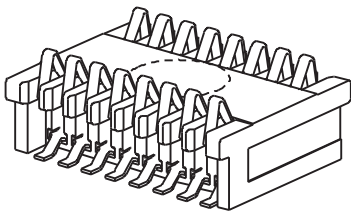

SMT PCB FOOTPRINT

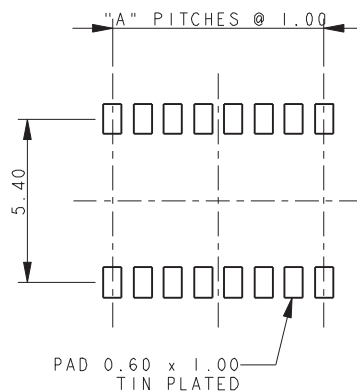

MATING PCB FOOTPRINT

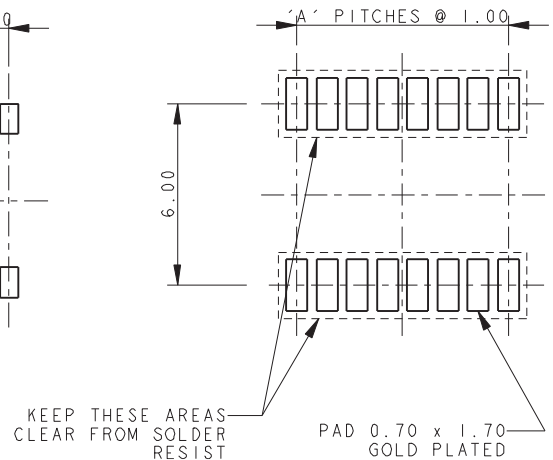

No of Positions	Part Number	A	B
16	00-9158-016-020-062	7	9.00
20	00-9158-020-020-062	9	11.00
24	00-9158-024-020-062	11	13.00
28	00-9158-028-020-062	13	15.00

Dual Row Stacker: 00-9158-BTB

2.0mm With Bosses

2.0MM DUAL ROW STACKER WITH BOSSES

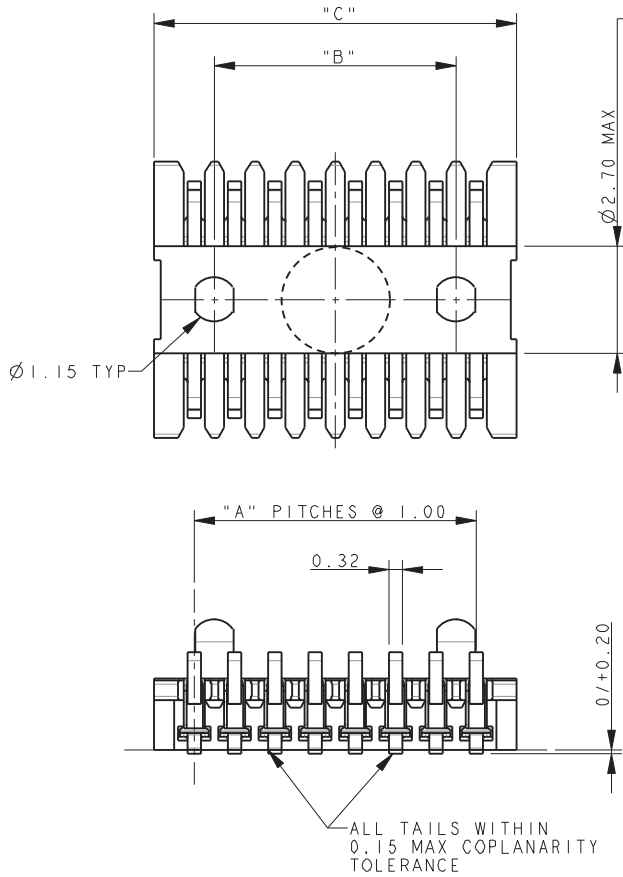

AVAILABLE VACUUM
PLACEMENT AREA

MATING CONDITION

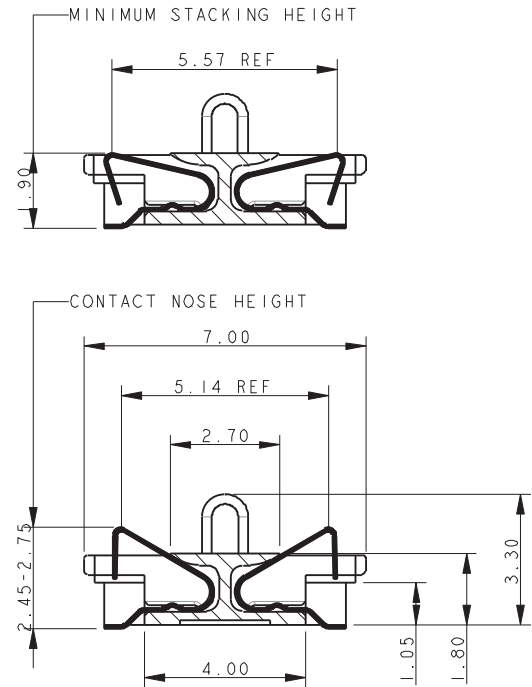

NOTES:

1. LAYOUT FOR MULTI-WAY DUAL ROW STACKING CONNECTOR (ELCO SERIES 9158).
2. FOR FULL PRODUCT SPECIFICATION REFER TO ELCO SPEC 201-01-073.
3. PART TO BE PACKED IN TAPE AND REEL. REFER TO PAGE 116 FOR DETAILS.
4. STACKER DESIGN TO ACCOMMODATE A PCB STACKING HEIGHT OF 1.90MM TO 2.10MM.
5. NO ALLOWANCE HAS BEEN MADE FOR SOLDER PASTE THICKNESS IN PCB STACKING HEIGHT.
6. GENERAL TOLERANCE ± 0.20 UNLESS OTHERWISE STATED.

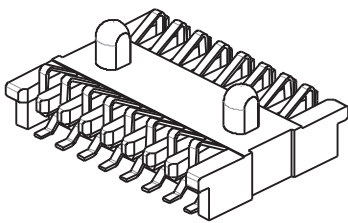

No of Positions	Part Number	A	B
16	00-9158-016-020-062	7	9.00
20	00-9158-020-020-062	9	11.00
24	00-9158-024-020-062	11	13.00
28	00-9158-028-020-062	13	15.00

SMT PCB FOOTPRINT

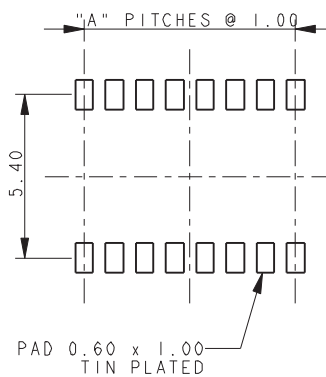

MATING PCB FOOTPRINT

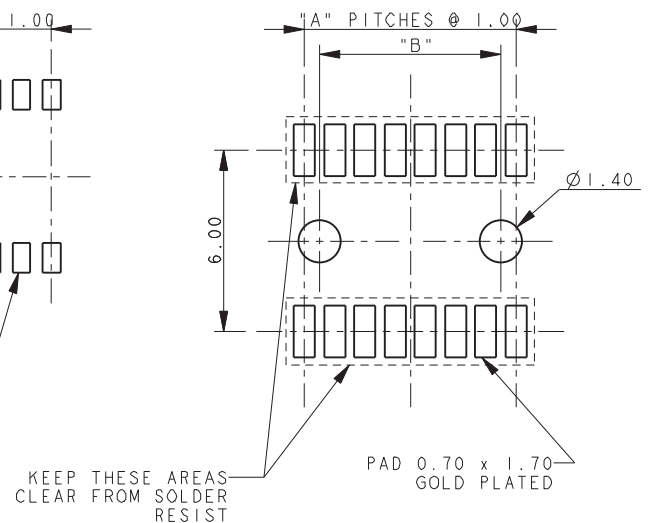

Dual Row Stacker: 00-9158-BTB

2.5mm With Bosses

2.5MM DUAL ROW STACKER WITH BOSSES

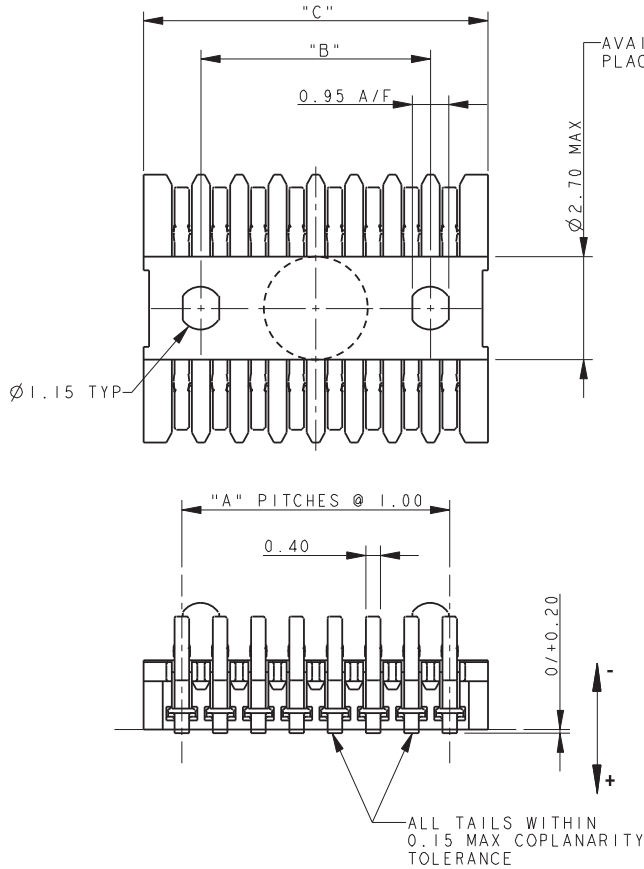

MATING CONDITION

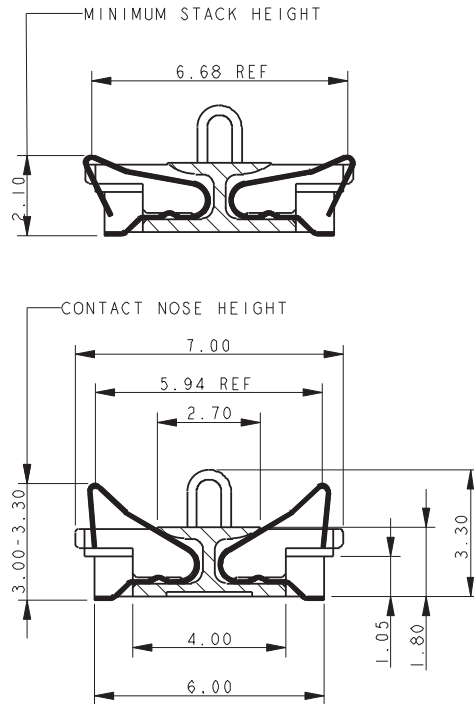

NOTES:

1. LAYOUT FOR MULTI-WAY DUAL ROW STACKING CONNECTOR (ELCO SERIES 9158).
2. FOR FULL PRODUCT SPECIFICATION REFER TO ELCO SPEC 201-01-073.
3. PART TO BE PACKED IN TAPE AND REEL. REFER TO PAGE 116 FOR DETAILS.
4. STACKER DESIGN TO ACCOMMODATE A PCB STACKING HEIGHT OF 2.10MM TO 2.70MM.
5. NO ALLOWANCE HAS BEEN MADE FOR SOLDER PASTE THICKNESS IN PCB STACKING HEIGHT.
6. GENERAL TOLERANCE ± 0.20 UNLESS OTHERWISE STATED.

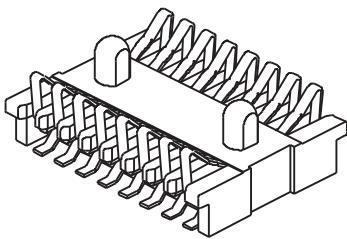

SMT PCB FOOTPRINT

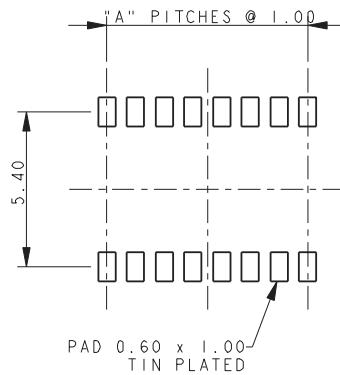

MATING PCB FOOTPRINT

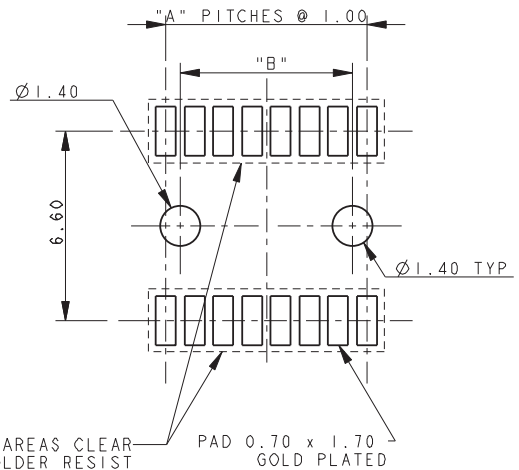

No of Positions	Part Number	A	B
16	00-9158-016-020-062	7	9.00
20	00-9158-020-020-062	9	11.00
24	00-9158-024-020-062	11	13.00
28	00-9158-028-020-062	13	15.00

Dual Row Stacker: 00-9158-BTB

3.0mm With Bosses

3.0MM DUAL ROW STACKER WITH BOSSES

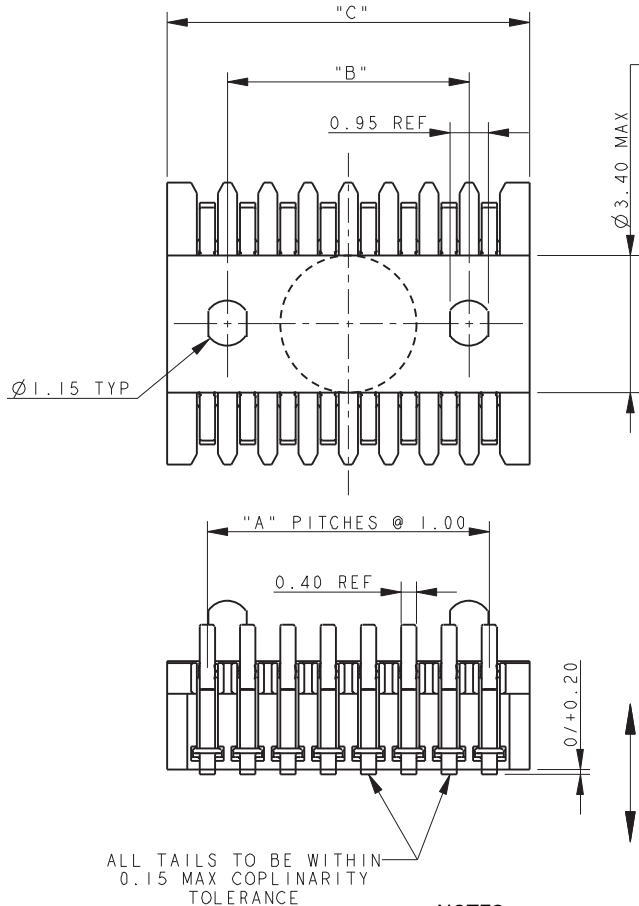

AVAILABLE VACUUM
PLACEMENT AREA

MATING CONDITION

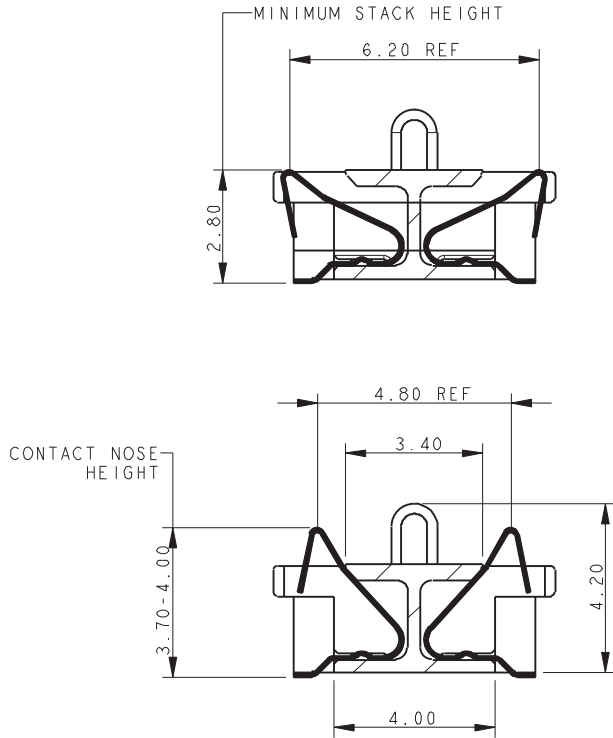

NOTES:

1. LAYOUT FOR MULTI-WAY DUAL ROW STACKING CONNECTOR (ELCO SERIES 9158).
2. FOR FULL PRODUCT SPECIFICATION REFER TO ELCO SPEC 201-01-073.
3. PART TO BE PACKED IN TAPE AND REEL. REFER TO PAGE 116 FOR DETAILS.
4. STACKER DESIGN TO ACCOMMODATE A PCB STACKING HEIGHT OF 2.80MM TO 3.30MM.
5. NO ALLOWANCE HAS BEEN MADE FOR SOLDER PASTE THICKNESS IN PCB STACKING HEIGHT.
6. GENERAL TOLERANCE ± 0.20 UNLESS OTHERWISE STATED.

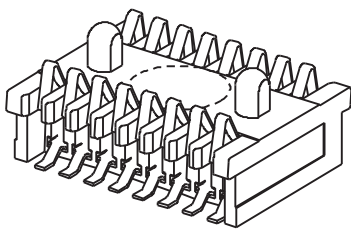

No of Positions	Part Number	A	B
16	00-9158-016-020-062	7	9.00
20	00-9158-020-020-062	9	11.00
24	00-9158-024-020-062	11	13.00
28	00-9158-028-020-062	13	15.00

SMT PCB FOOTPRINT

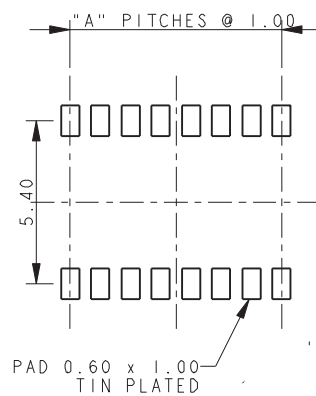

MATING PCB FOOTPRINT

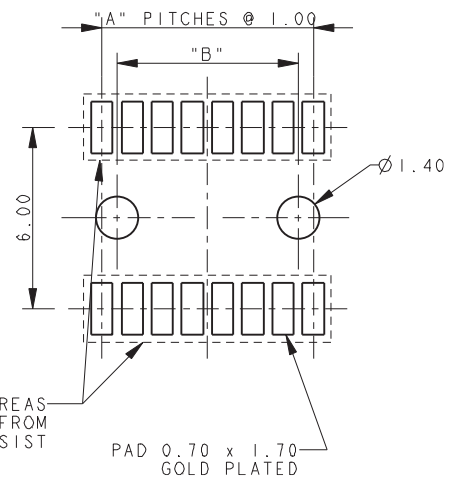

Dual Row Stacker: 00-9158-BTB

Limits to PCB Misalignment & Packing Details

LIMITS TO PCB MISALIGNMENT

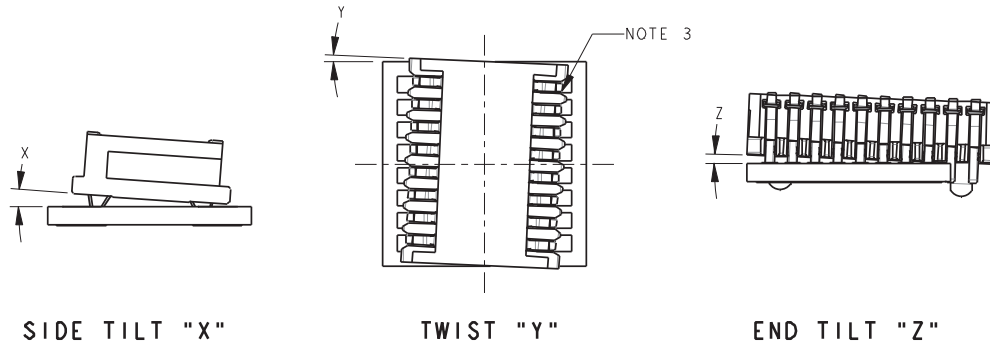

Code (See page 107)	Stack Height (Note 1)	Max Angle Degrees on Axis (Note 4)	Number of Ways			
			16	20	24	28
020	1.9mm to 2.1mm	X	2.0	2.0	2.0	2.0
		Y	3.5	3.5	3.5	3.5
		Z	2.0	1.5	1.0	1.0
025	2.1mm to 2.7mm	X	4.0	4.0	4.0	4.0
		Y	2.5	2.5	2.5	2.5
		Z	4.0	3.0	2.5	2.0
030	2.7mm to 3.3mm	X	4.0	4.0	4.0	4.0
		Y	2.5	2.5	2.5	2.5
		Z	3.5	2.5	2.0	2.0

NOTES:

1. PCB STACK HEIGHT (REF PAGE 109). THIS IS THE CONTROLLING LIMIT ON THE GAP BETWEEN THE TWO PCB FACES AT ANY POINT WHEN IN THE FINAL MATED POSITION.
2. NO ALLOWANCE HAS BEEN MADE FOR SOLDER PASTE THICKNESS IN PCB STACKING HEIGHT.
3. IT IS CRITICAL THAT ON ASSEMBLY THE CONTACT NOSES DO NOT STRAY OUTSIDE OF THE MATING PAD AREA IN THE FINAL MATED POSITION.
4. THE MAXIMUM MISALIGNMENT ABOUT ANY ONE AXIS IN DEGREES. SEE NOTES 1 AND 3.

PACKING DETAILS 9158 SOLO STACKER CONNECTORS

No of Positions	Stack Height	Bosses	Part Number	Tape Width	Reel Qty.
16	2.0	Yes	00-9158-016-020-0X1	16	1250
16	2.0	No	00-9158-016-020-0X2	16	1500
16	2.5	Yes	00-9158-016-025-0X1	16	1250
16	2.5	No	00-9158-016-025-0X2	16	1250
16	3.0	Yes	00-9158-016-030-0X1	16	1100
16	3.0	No	00-9158-016-030-0X2	16	1100
20	2.0	Yes	00-9158-020-020-0X1	24	1250
20	2.0	No	00-9158-020-020-0X2	24	1500
20	2.5	Yes	00-9158-020-025-0X1	24	1250
20	2.5	No	00-9158-020-025-0X2	24	1250
20	3.0	Yes	00-9158-020-030-0X1	24	1100
20	3.0	No	00-9158-020-030-0X2	24	1100
24	2.0	Yes	00-9158-024-020-0X1	24	1250
24	2.0	No	00-9158-024-020-0X2	24	1500
24	2.5	Yes	00-9158-024-025-0X1	24	1250
24	2.5	No	00-9158-024-025-0X2	24	1250
24	3.0	Yes	00-9158-024-030-0X1	24	1100
24	3.0	No	00-9158-024-030-0X2	24	1100
28	2.0	Yes	00-9158-028-020-0X1	24	1250
28	2.0	No	00-9158-028-020-0X2	24	1500
28	2.5	Yes	00-9158-028-025-0X1	24	1250
28	2.5	No	00-9158-028-025-0X2	24	1250
28	3.0	Yes	00-9158-028-030-0X1	24	1100
28	3.0	No	00-9158-028-030-0X2	24	1100

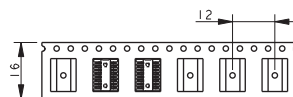
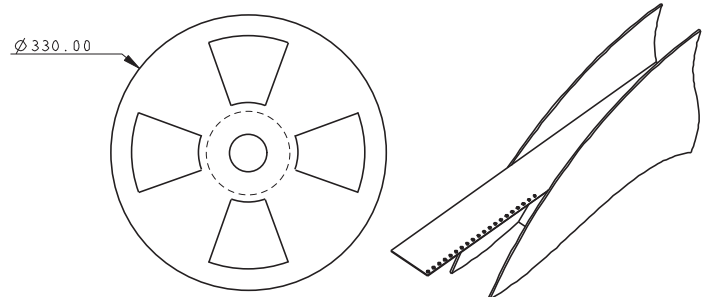

TYPICAL 16 WAY
(SHOWN WITH BOSSES)

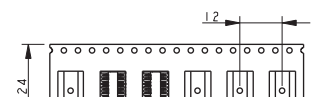

TYPICAL 20 WAY
(SHOWN WITHOUT BOSSES)

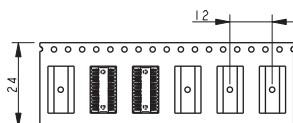

TYPICAL 24 WAY
(SHOWN WITH BOSSES)

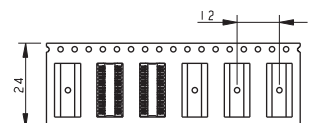

TYPICAL 28 WAY
(SHOWN WITHOUT BOSSES)

Staggered Stacker: 00-9188-BTB

General Description

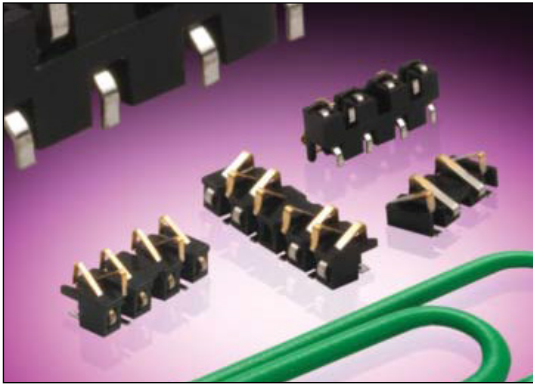

The SOLO series 9188 is a one-piece connector used to connect two PCBs in a cost effective manner.

A standard range is available with 4, 6, 8 staggered contacts to suit stack heights of 1.1mm to 2.1mm (see table below).

SOLO Stacker is designed for PCB surface mounting and is supplied in tape and reel packaging. Gold plated pads on the mating PCB or suitable flex circuits provide connection between the two boards.

APPLICATIONS

- Phones
- Scanners
- Radios
- Medical Diagnostic
- Security Devices

FEATURES AND BENEFITS

Single piece connector – no mating half required to connect two boards together which means:

- Reduced assembly time
- Only one part to purchase and stock
- Due to the unique contact design, the mating device does not have to be parallel
- Helps reduce tolerance accumulation within system

ELECTRICAL

- Current Rating: 1 Amp/Contact
- Voltage Rating: 125V
Based on placement distance

ENVIRONMENTAL

- Operating Temperature:
-55°C to +125°C

MECHANICAL

- Insulator Material: High Temperature Plastic; UL94 HB
- Contact Material: Beryllium Copper
- Plating: Gold over Nickel
- Durability: 50 Cycles

HOW TO ORDER

00
Prefix

9188
Series

00X
Number of Ways
004 = 4
006 = 6
008 = 8

OXX
Stack Height

Code	Height	No. of Ways
012	1.1mm to 1.3mm	4 only
020	1.9mm to 2.1mm	4, 6, & 8

062
Plating Variation
062 = Selective Gold
0.25µm Gold Plated
Contact Nose Pure
Tin Tail



Staggered Stacker: 00-9188-BTB

4 Position 1.2mm

4 WAY STAGGERED STACKER – 1.2MM HEIGHT

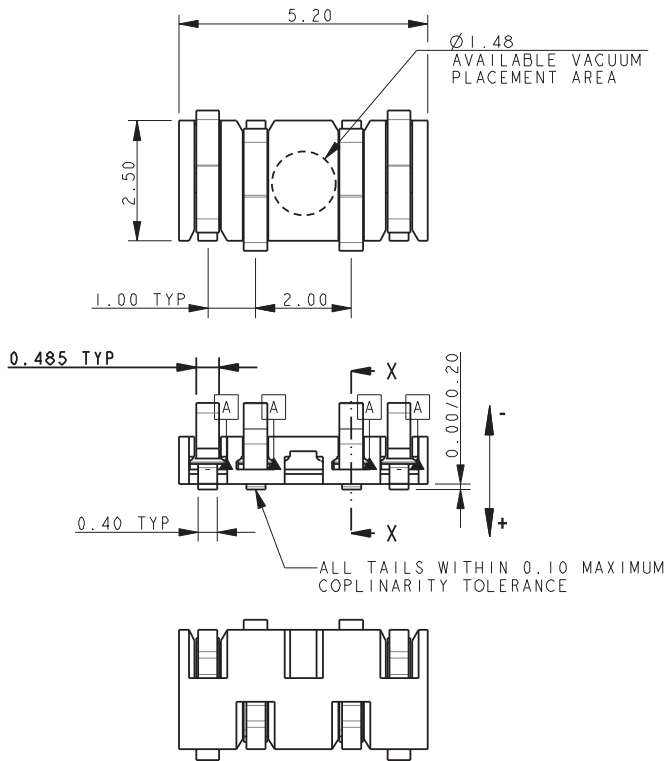

MATING CONDITION

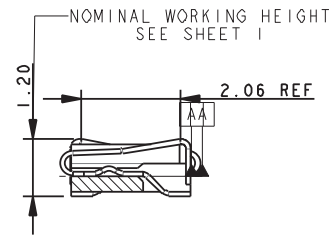

SECTION ON X-X

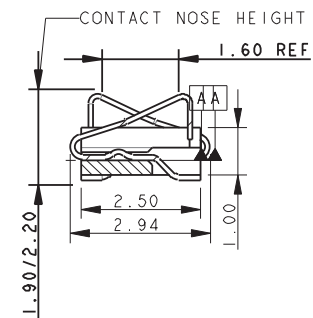

SMT PCB FOOTPRINT

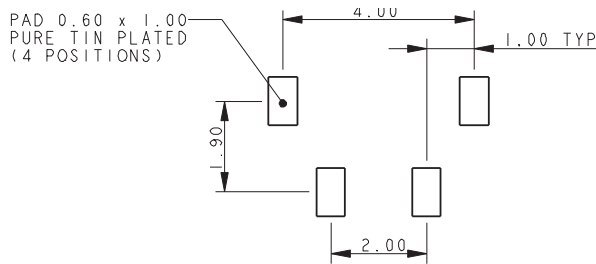

MATING PCB FOOTPRINT

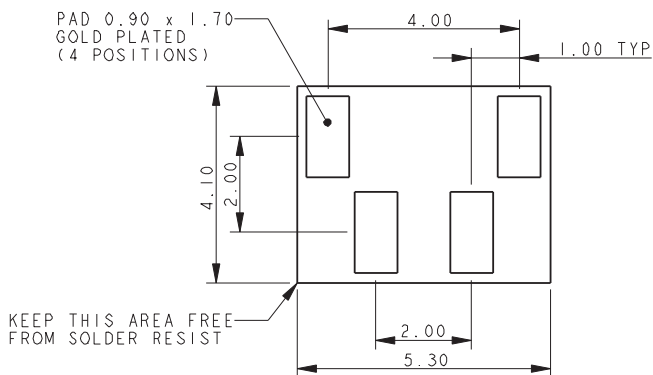

PACKING DETAILS

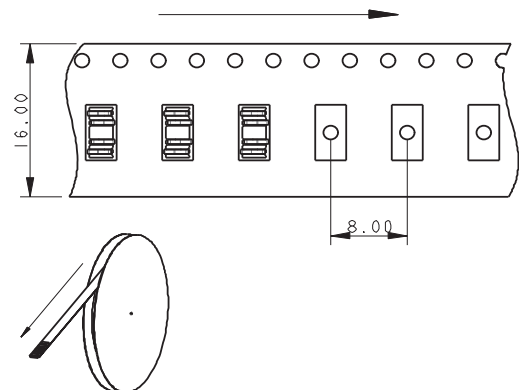

NOTES:

1. GENERAL TOLERANCE ± 0.20 UNLESS SPECIFIED.
2. FOR FULL PRODUCT SPECIFICATION REFER TO ELCO SPECIFICATION 201-01-121.
3. INSULATOR MATERIAL: HIGH TEMPERATURE PLASTIC UL94 HB. COLOR BLACK.
4. CONTACT MATERIAL: COPPER ALLOY.
5. CONTACT PLATING: 1.0 M NICKEL UNDERPLATED. SELECTIVE 0.25 M GOLD ON NOSE. 2.0 TO 4.0 M PURE TIN ON TAILS.
6. PACKING 2000 PIECES ON A 330MM REEL.

Staggered Stacker: 00-9188-BTB

4 Position 2.0mm

4 WAY STAGGERED STACKER – 2.0MM HEIGHT

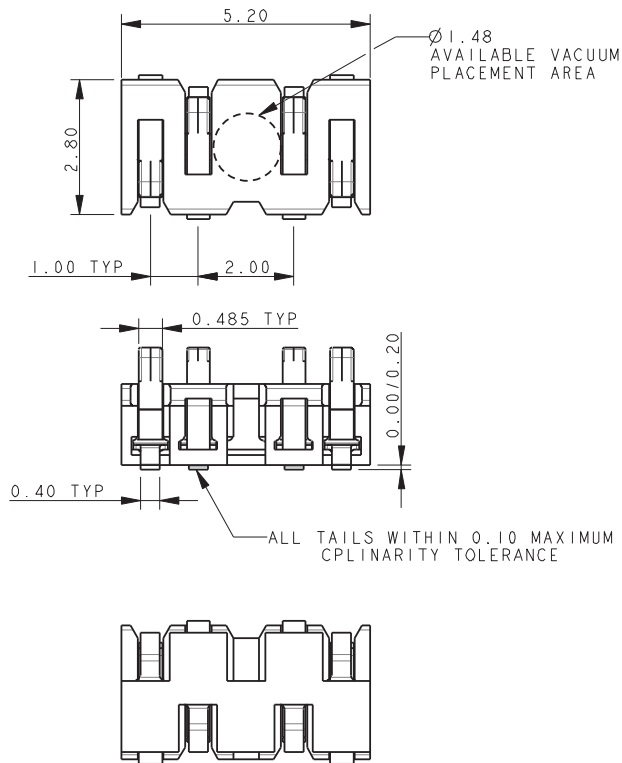

MATING CONDITION

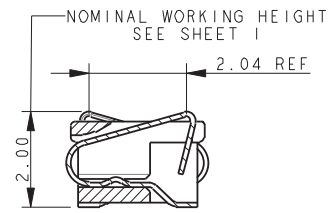

SECTION ON X-X

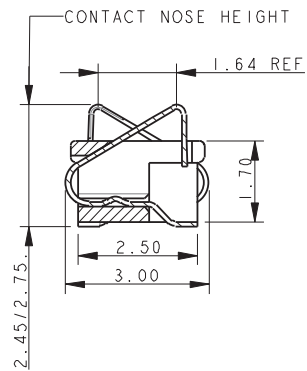

SMT PCB FOOTPRINT

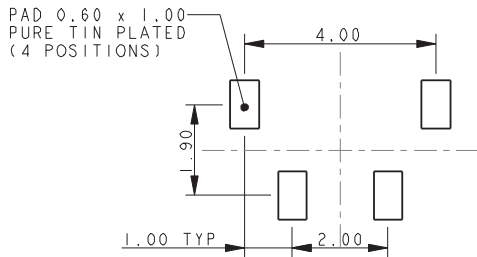

MATING PCB FOOTPRINT

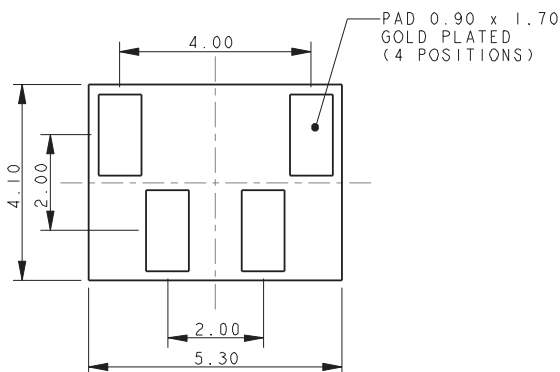

NOTES:

1. GENERAL TOLERANCE ± 0.20 UNLESS SPECIFIED.
2. FOR FULL PRODUCT SPECIFICATION REFER TO ELCO SPECIFICATION 201-01-121.
3. INSULATOR MATERIAL: HIGH TEMPERATURE PLASTIC UL94 HB. COLOR BLACK.
4. CONTACT MATERIAL: COPPER ALLOY.
5. CONTACT PLATING: 1.0 M NICKEL UNDERPLATED. SELECTIVE 0.25 M GOLD ON NOSE. 2.0 TO 4.0 M PURE TIN ON TAILS.
6. PACKING 2000 PIECES ON A 330MM REEL.

PACKING DETAILS

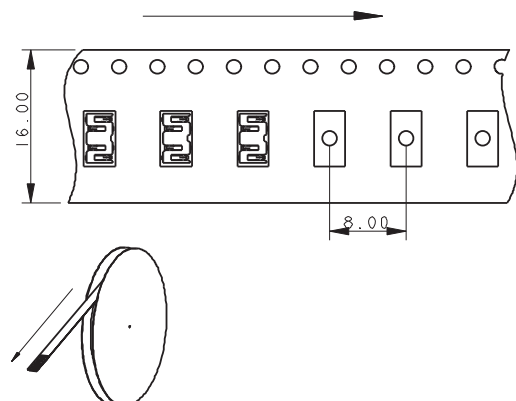

Staggered Stacker: 00-9188-BTB

6 Position 2.0mm

6 WAY STAGGERED STACKER – 2.0MM HEIGHT

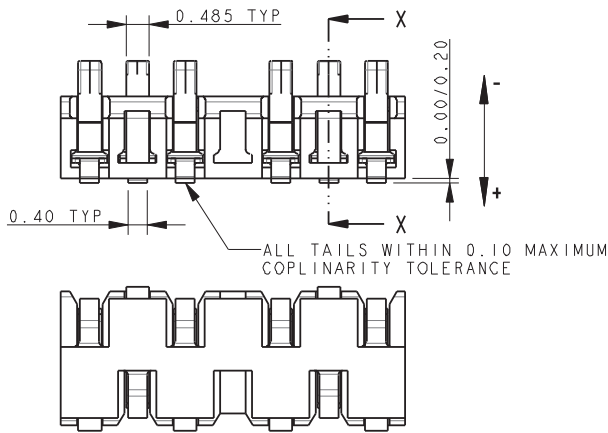
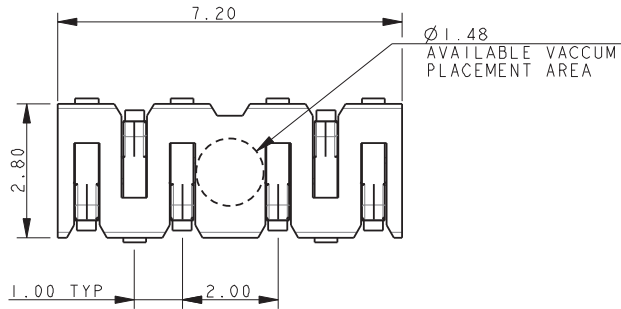

SMT PCB FOOTPRINT

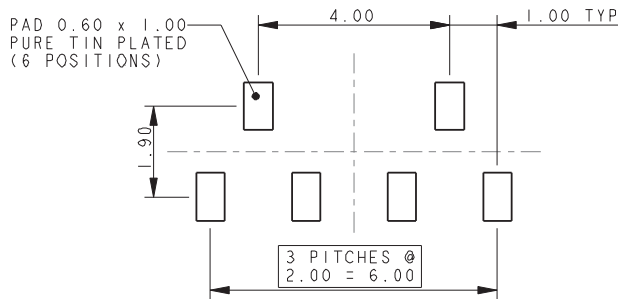

MATING PCB FOOTPRINT

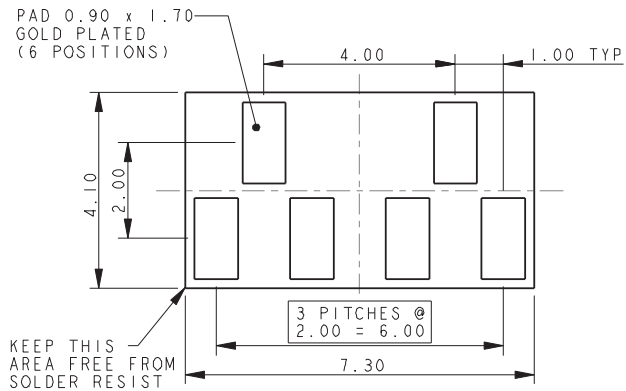

MATING CONDITION

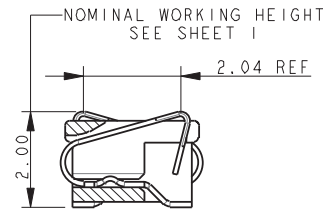

SECTION ON X-X

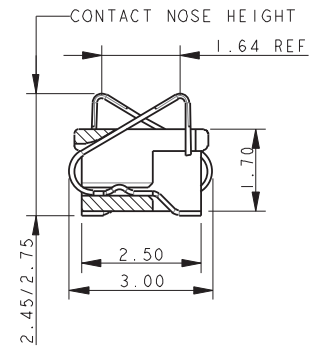

NOTES:

1. GENERAL TOLERANCE ± 0.20 UNLESS SPECIFIED.
2. FOR FULL PRODUCT SPECIFICATION REFER TO ELCO SPECIFICATION 201-01-121.
3. INSULATOR MATERIAL: HIGH TEMPERATURE PLASTIC UL94 HB. COLOR BLACK.
4. CONTACT MATERIAL: COPPER ALLOY.
5. CONTACT PLATING: 1.0 M NICKEL UNDERPLATED. SELECTIVE 0.25 M GOLD ON NOSE. 2.0 TO 4.0 M PURE TIN ON TAILS.
6. PACKING 2000 PIECES ON A 330MM REEL.

PACKING DETAILS

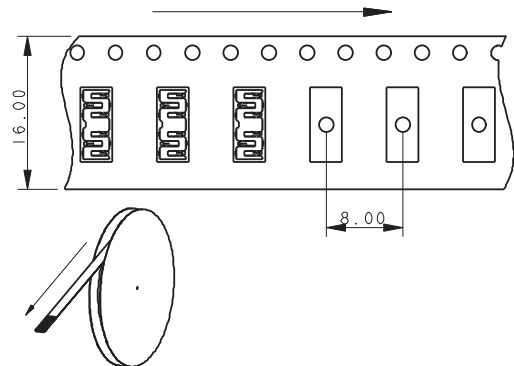

Staggered Stacker: 00-9188-BTB

8 Position 2.0mm

8 WAY STAGGERED STACKER – 2.0MM HEIGHT

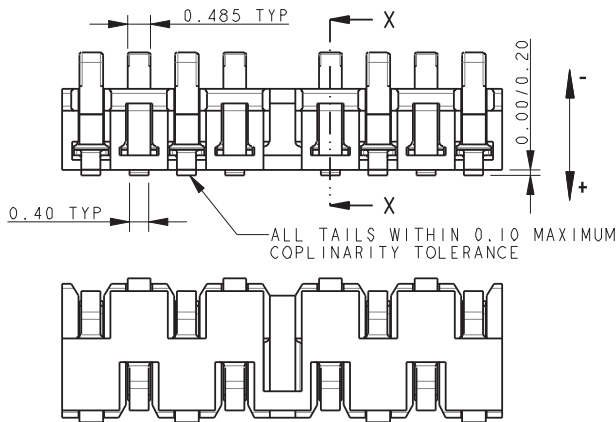
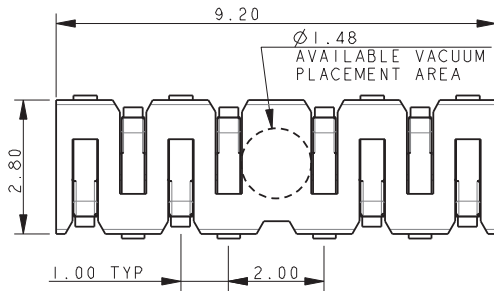

SMT PCB FOOTPRINT

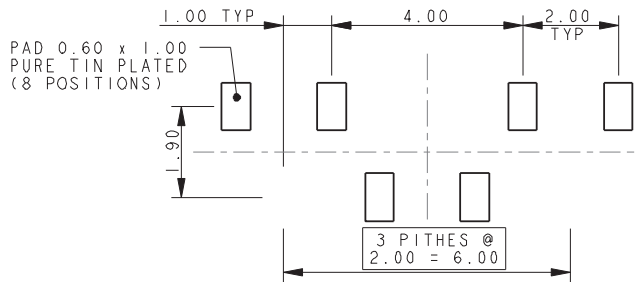

MATING PCB FOOTPRINT

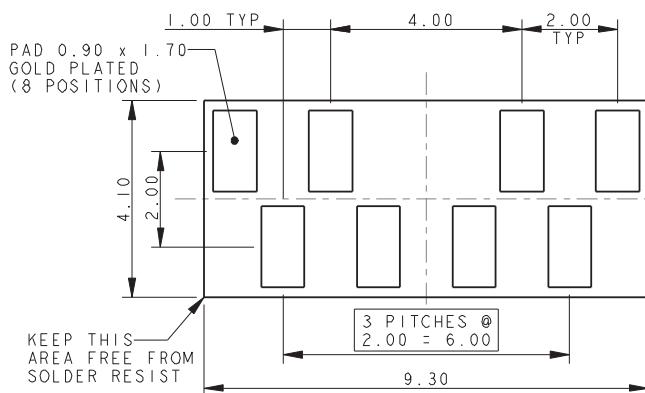

MATING CONDITION

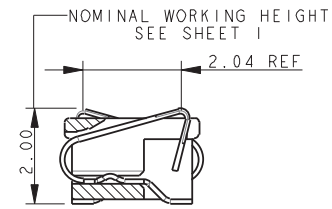

SECTION ON X-X

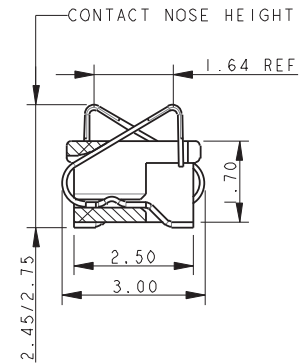

NOTES:

1. GENERAL TOLERANCE ± 0.20 UNLESS SPECIFIED.
2. FOR FULL PRODUCT SPECIFICATION REFER TO ELCO SPECIFICATION 201-01-121.
3. INSULATOR MATERIAL: HIGH TEMPERATURE PLASTIC UL94 HB. COLOR BLACK.
4. CONTACT MATERIAL: COPPER ALLOY.
5. CONTACT PLATING: 1.0 M NICKEL UNDERPLATED. SELECTIVE 0.25 M GOLD ON NOSE. 2.0 TO 4.0 M PURE TIN ON TAILS.
6. PACKING 2000 PIECES ON A 330MM REEL.

PACKING DETAILS

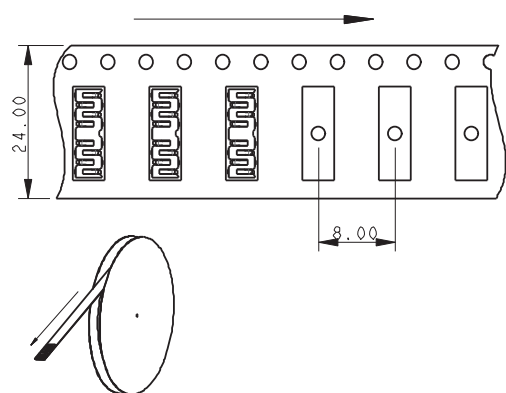

Ultra Low Profile Stacker: 00-9258-BTB

General Description

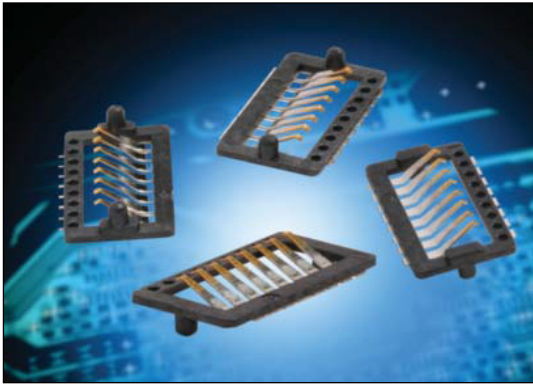

The SOLO series 9258 is a one-piece connector used to connect two PCBs in a cost effective manner.

This connector is a 1.0mm pitch available in an 8 position with stack heights of 0.40mm and 0.80mm. It is available with or without location bosses.

This connector is designed for PCB surface mounting and is supplied in tape and reel packaging. Gold plated pads on the mating PCB or suitable flex circuits provide connection between the boards.

APPLICATIONS

- Mobile phones
- Handheld scanners
- Portable medical devices
- Display interface

FEATURES AND BENEFITS

Single piece connector – no mating half connector required to connect two boards together which means:

- Reduced assembly time
- Only one part to purchase and stock
- Due to the unique contact design, the mating device does not have to be parallel
- Extremely robust when it comes to shock and vibration

ELECTRICAL

- Current Rating: 1 Amp/Contact
- Voltage Rating: 125V
Based on placement distance

ENVIRONMENTAL

- Operating Temperature:
-55°C to +125°C

MECHANICAL

- Insulator Material: High Temperature Plastic; UL94 V-0
- Contact Material: Beryllium Copper
- Plating: Gold over Nickel
- Durability: 50 Cycles

HOW TO ORDER

00 **9258** **008**
 Prefix Series Number of Ways
 008 = 8

00X

Connector Height

Code	Stack Height	Contact Height	Qty
004	0.40mm	1.00-1.30	No. of Ways
008	0.80mm	1.40-1.70	

06

Plating Variation

06 = Selective Gold
 0.25µm Gold Plated
 Contact Nose Pure
 Tin Tail

X

PCB Location Bosses

1 = With PCB Location Bosses (top side)
 2 = Without PCB Location Bosses
 3 = With SMT PCB Location Bosses (bottom side)
 4 = With SMT and Mating PCB Location Bosses (top and bottom side)



Ultra Low Profile Stacker: 00-9258-BTB

0.4mm

0.4MM ULTRA LOW PROFILE STACKER

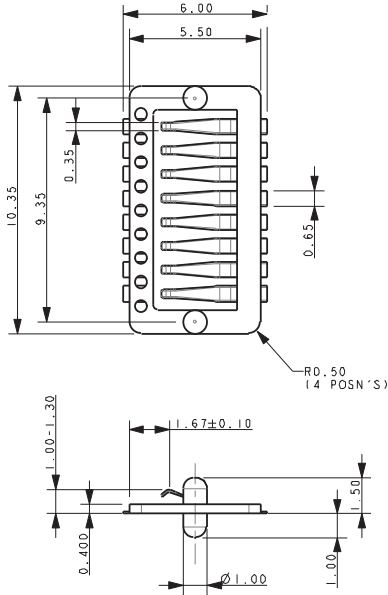

NOTES:

1. 8 WAY ULTRA LOW PROFILE STACKER IN 0.8MM STACK HEIGHT.
2. INSULATOR MATERIAL: NYLON 46 HF5040, 40% GLASS FILLED UL94 V-0. COLOR BLACK.
3. CONTACT MATERIAL; 0.10MM THICK BeCu.
4. CONTACT PLATING: NICKEL UNDERPLATE, SELECTIVE GOLD PLATED CONTACT NOSES PURE TIN PLATED CONTACT SMT TAILS.
5. PARTS TO BE PACKED IN TAPE AND REEL, QTY: 1200.
6. ALL DIMENSIONS FOR REFERENCE UNLESS TOLERANCED.
7. FOR FURTHER INFORMATION REFER TO SPECIFICATION 201-01-115.

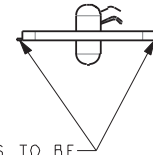
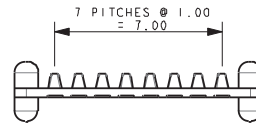

ALL TAILS TO BE WITHIN 0.10 MAX COPLANARITY TOLERANCE

PROPOSED SMT PCB LAYOUT

ALL PADS PURE TIN PLATE

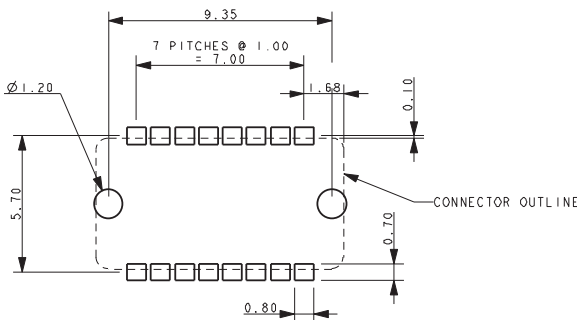

PROPOSED MATING PCB LAYOUT

ALL PADS GOLD PLATE

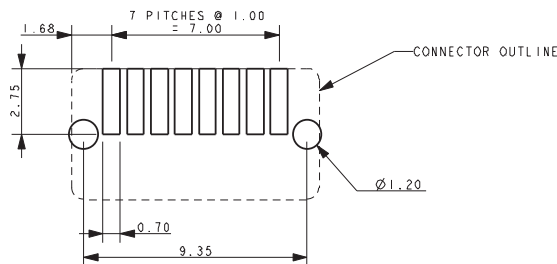

PACKING TAPE DETAILS

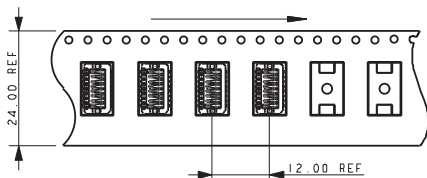

WITH MATING PCB LOCATION BOSSES

(TOP SIDE)

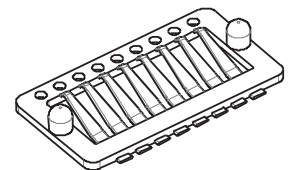

WITHOUT PCB LOCATION BOSSES

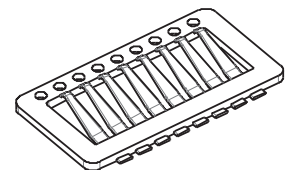

WITH SMT PCB LOCATION BOSSES

(BOTTOM SIDE)

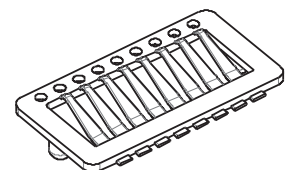

WITH PCB AND SMT LOCATION BOSSES

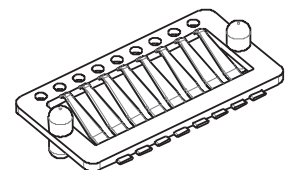

Ultra Low Profile Stacker: 00-9258-BTB

0.8mm

0.8MM ULTRA LOW PROFILE STACKER

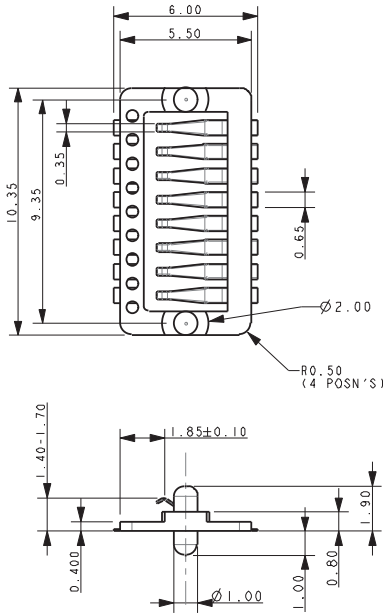

NOTES:

1. 8 WAY ULTRA LOW PROFILE STACKER IN 0.4MM STACK HEIGHT.
2. INSULATOR MATERIAL: NYLON 46 HF5040, 40% GLASS FILLED UL94 V-0. COLOR BLACK.
3. CONTACT MATERIAL; 0.10MM THICK BeCu.
4. CONTACT PLATING: NICKEL UNDERPLATE, SELECTIVE GOLD PLATED CONTACT NOSES PURE TIN PLATED CONTACT SMT TAILS.
5. PARTS TO BE PACKED IN TAPE AND REEL, QTY: 1400.
6. ALL DIMENSIONS FOR REFERENCE UNLESS TOLERANCED.
7. FOR FURTHER INFORMATION REFER TO SPECIFICATION 201-01-115.

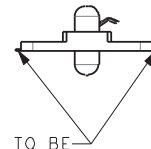
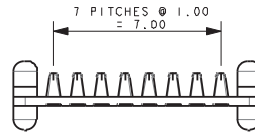

ALL TAILS TO BE WITHIN 0.10 MAX COPLANARITY TOLERANCE

PROPOSED SMT PCB LAYOUT

ALL PADS PURE TIN PLATE

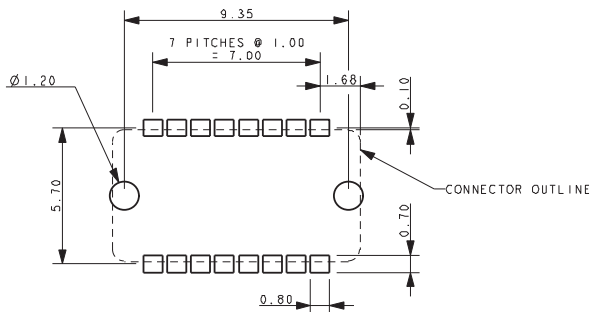

WITH MATING PCB LOCATION BOSSES

(TOP SIDE)

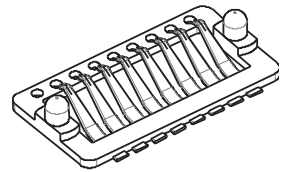

PROPOSED MATING PCB LAYOUT

ALL PADS GOLD PLATE

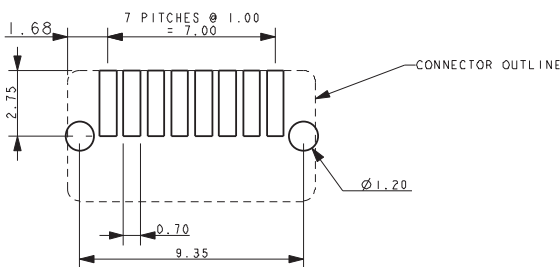

WITHOUT PCB LOCATION BOSSES

WITH SMT PCB LOCATION BOSSES

(BOTTOM SIDE)

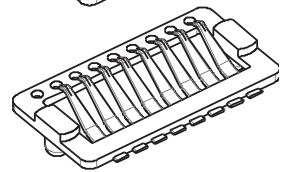
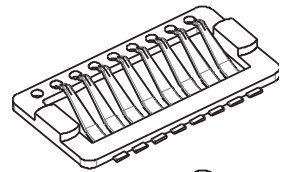

PACKING TAPE DETAILS

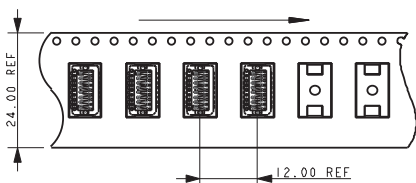

WITH PCB AND SMT LOCATION BOSSES

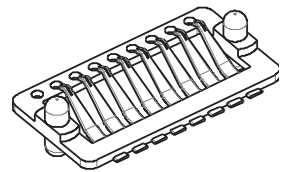

Pogo Pin Single Contact: 70-9150-BTB

General Description

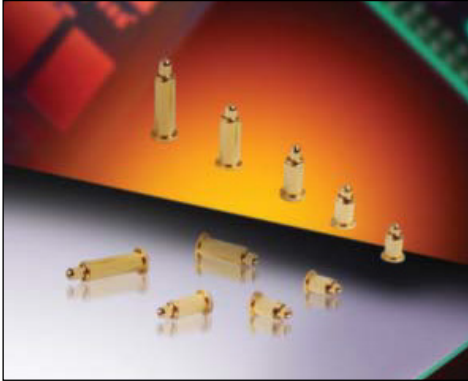

Single Pogo Pin contacts provide high cycle life in industrial and medical applications where reliability and robustness is critical. Pogo Pins provide 10,000 mating cycles and are ideal in pluggable module applications where the end customer has to handle a product daily. Pogo Pins are designed to mate with gold plated PCB pads or flat contacts in docking/cradle applications to function as the charging, data transfer or programming interface to a portable device.

The standard range single contacts from KYOCERA AVX provides the maximum flexibility in pin count, placement location and broad compressed stacking heights ranging from 2.0mm up to 5.5mm. The contacts are provided in standard tape and reel packaging for automatic in-line SMT placement. A disposable plastic cap facilitates vacuum pick-up and then is removed after reflow soldering prior to product mating. Contacts are gold plated and incorporate high force stainless steel springs for durability and signal integrity.

APPLICATIONS

- Base/Docking stations for portable electronic devices to recharge batteries or download data
- Testing and programming of electronic modules
- Interface to disposable medical or measurement components

FEATURES AND BENEFITS

- Contacts range from 2.0mm to 5.5mm providing off-the-shelf availability for almost any application
- Each contact height provides the maximum working range and compressed height tolerance possible
- Gold plated contacts provide high reliability and signal integrity over 10,000 cycles
- Removable pick-up cap facilitates automatic placement for SMT reflow

ELECTRICAL

- Current Rating: 1 Amp
- Voltage Rating:
Based on placement distance

ENVIRONMENTAL

- Operating Temperature:
-40°C to +125°C

MECHANICAL

- Contact Material: Brass
- Contact Plating: Gold over Nickel
- Spring Material: SUS304
- Durability: 10k Cycles

HOW TO ORDER

70	9150	001	0XX	0	0	6
Prefix	Series	Number of Ways	Contact Operating Range	Sleeve Diameter	Packing Option	Plating Option
70 = Contact		001 = 1	020 = 1.90 to 2.30 025 = 2.40 to 2.80 030 = 2.90 to 3.40 040 = 3.90 to 4.50 050 = 4.90 to 5.50	0 = 1.50	0 = Tape & Reel	6 = Gold over Nickel



Pogo Pin Single Contact: 70-9150-BTB

2mm High Pin

1.50MM DIAMETER 2MM HIGH POGO PIN

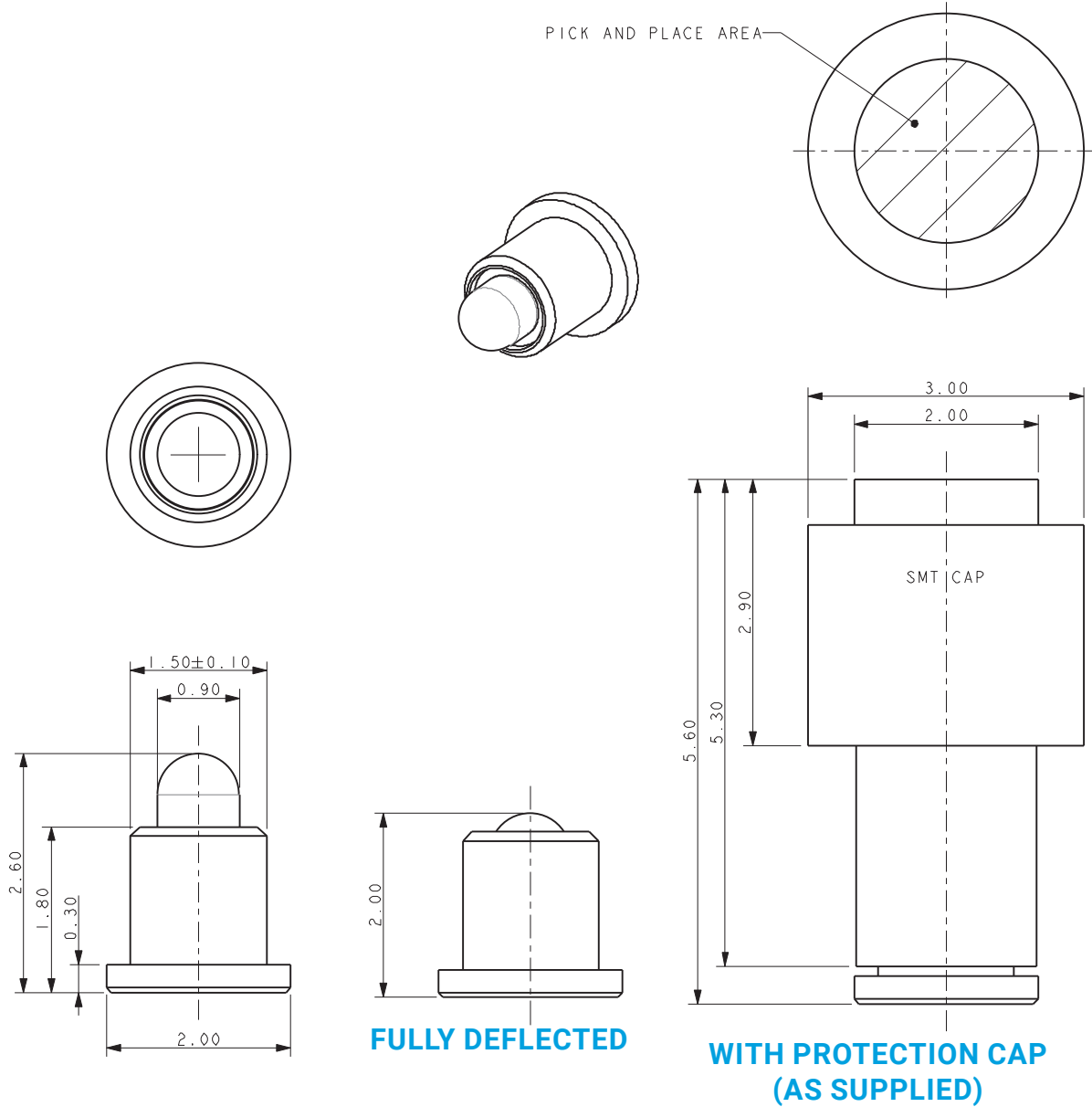

NOTES:

1. SERIES 9150 POGO PIN, WORKING HEIGHT 2MM TO 2.3MM.
2. MATERIAL: PIN AND SLEEVE, COPPER ALLOW PLATED GOLD OVER NICKEL. SPRING STAINLESS STEEL.
3. SUPPLIED WITH A PROTECTION CAP IN PA9T. SUITABLE FOR PICK AND PLACE AND RE-FLOW.
4. PACKING IN TAPE AND REEL, QUANTITY PER REEL 1400.
5. DURABILITY 10,000 OPERATIONS FOR OTHER PRODUCT DETAILS REFER TO SPECIFICATION 201-01-158.
6. GENERAL TOLERANCE ± 0.20 UNLESS STATED.
7. PCB DETAILS ON PAGE 131.

PACKING DETAILS

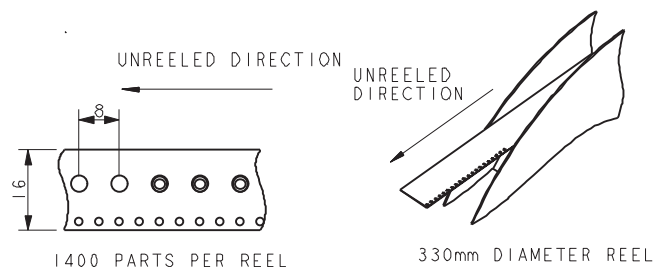

Pogo Pin Single Contact: 70-9150-BTB

2.5mm High Pin

1.50MM DIAMETER 2.5MM HIGH POGO PIN

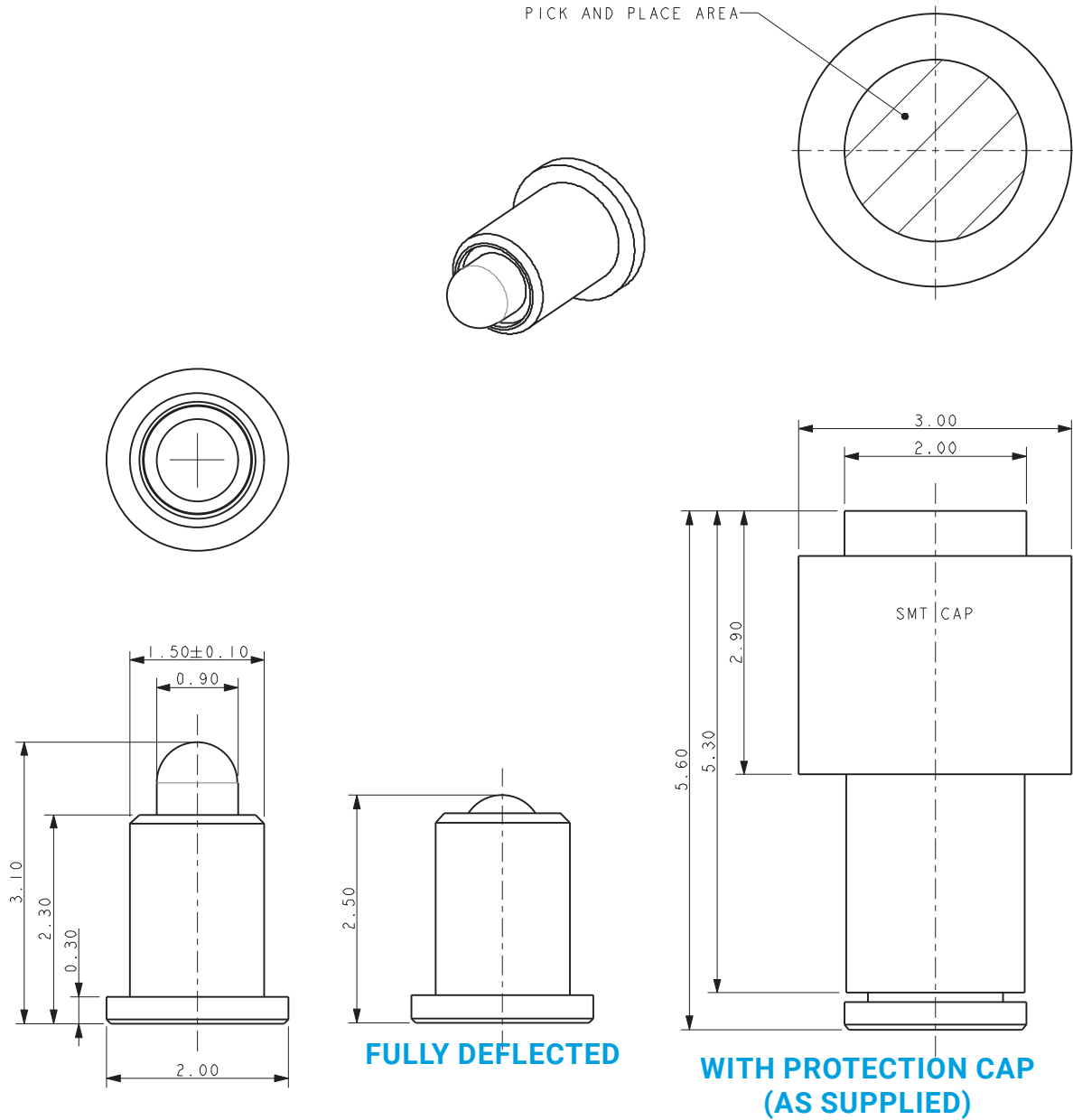

NOTES:

1. SERIES 9150 POGO PIN, WORKING HEIGHT 2.5MM TO 2.8MM.
2. MATERIAL: PIN AND SLEEVE, COPPER ALLOW PLATED GOLD OVER NICKEL. SPRING STAINLESS STEEL.
3. SUPPLIED WITH A PROTECTION CAP IN PA9T. SUITABLE FOR PICK AND PLACE AND RE-FLOW.
4. PACKING IN TAPE AND REEL, QUANTITY PER REEL 1400.
5. DURABILITY 10,000 OPERATIONS FOR OTHER PRODUCT DETAILS REFER TO SPECIFICATION 201-01-158.
6. GENERAL TOLERANCE ± 0.20 UNLESS STATED.
7. PCB DETAILS ON PAGE 131.

PACKING DETAILS

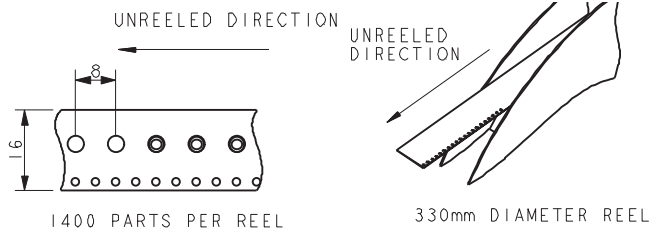

Pogo Pin Single Contact: 70-9150-BTB

3mm High Pin

1.50MM DIAMETER 3MM HIGH POGO PIN

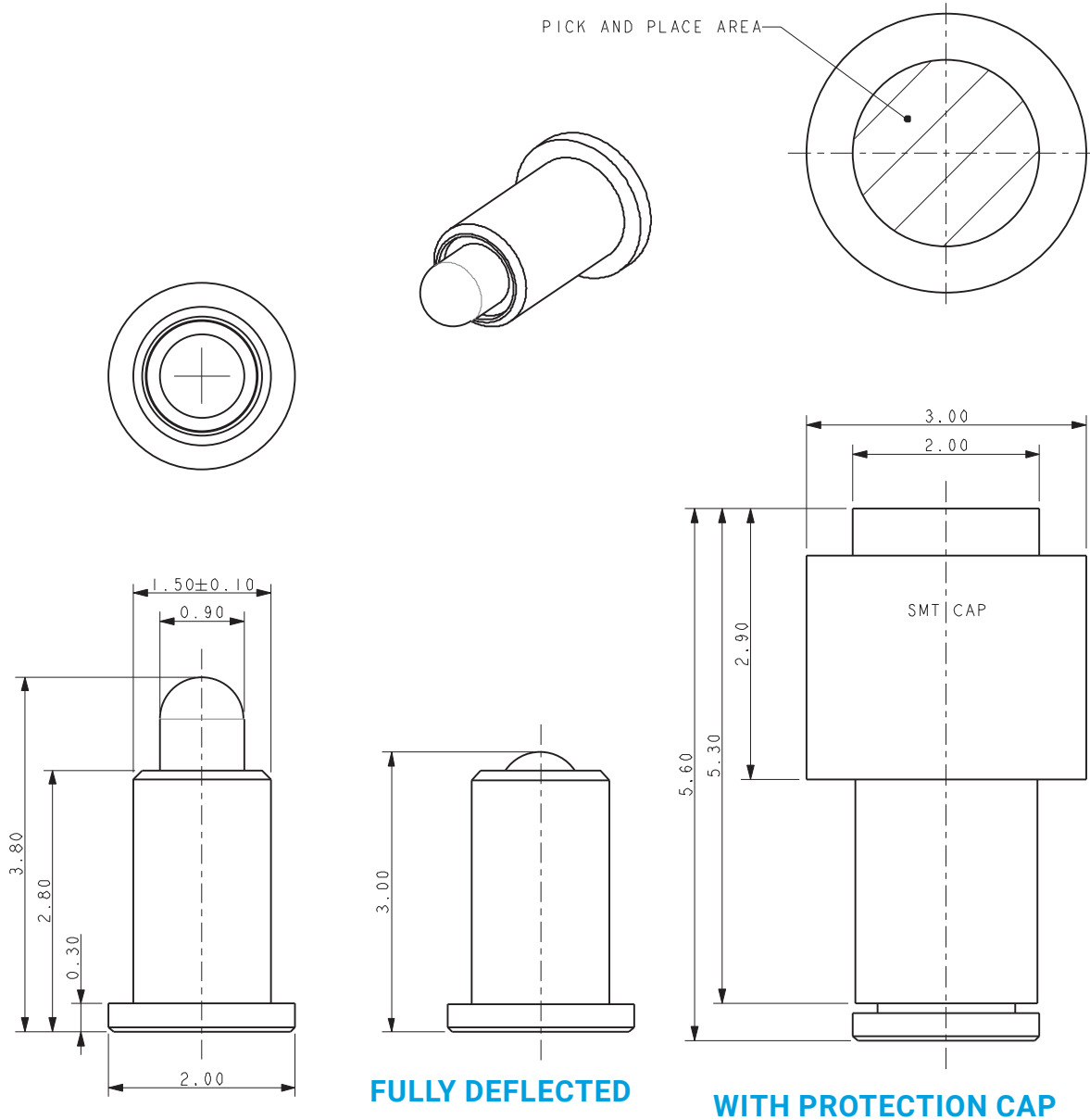

NOTES:

1. SERIES 9150 POGO PIN, WORKING HEIGHT 3MM TO 3.4MM.
2. MATERIAL: PIN AND SLEEVE, COPPER ALLOW PLATED GOLD OVER NICKEL. SPRING STAINLESS STEEL.
3. SUPPLIED WITH A PROTECTION CAP IN PA9T. SUITABLE FOR PICK AND PLACE AND RE-FLOW.
4. PACKING IN TAPE AND REEL, QUANTITY PER REEL 1400.
5. DURABILITY 10,000 OPERATIONS FOR OTHER PRODUCT DETAILS REFER TO SPECIFICATION 201-01-158.
6. GENERAL TOLERANCE ± 0.20 UNLESS STATED.
7. PCB DETAILS ON PAGE 131.

PACKING DETAILS

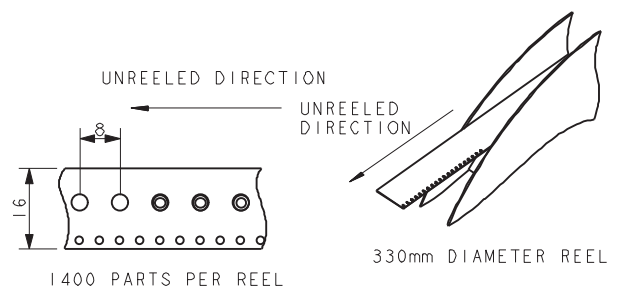

Pogo Pin Single Contact: 70-9150-BTB

4mm High Pin

1.50MM DIAMETER 4MM HIGH POGO PIN

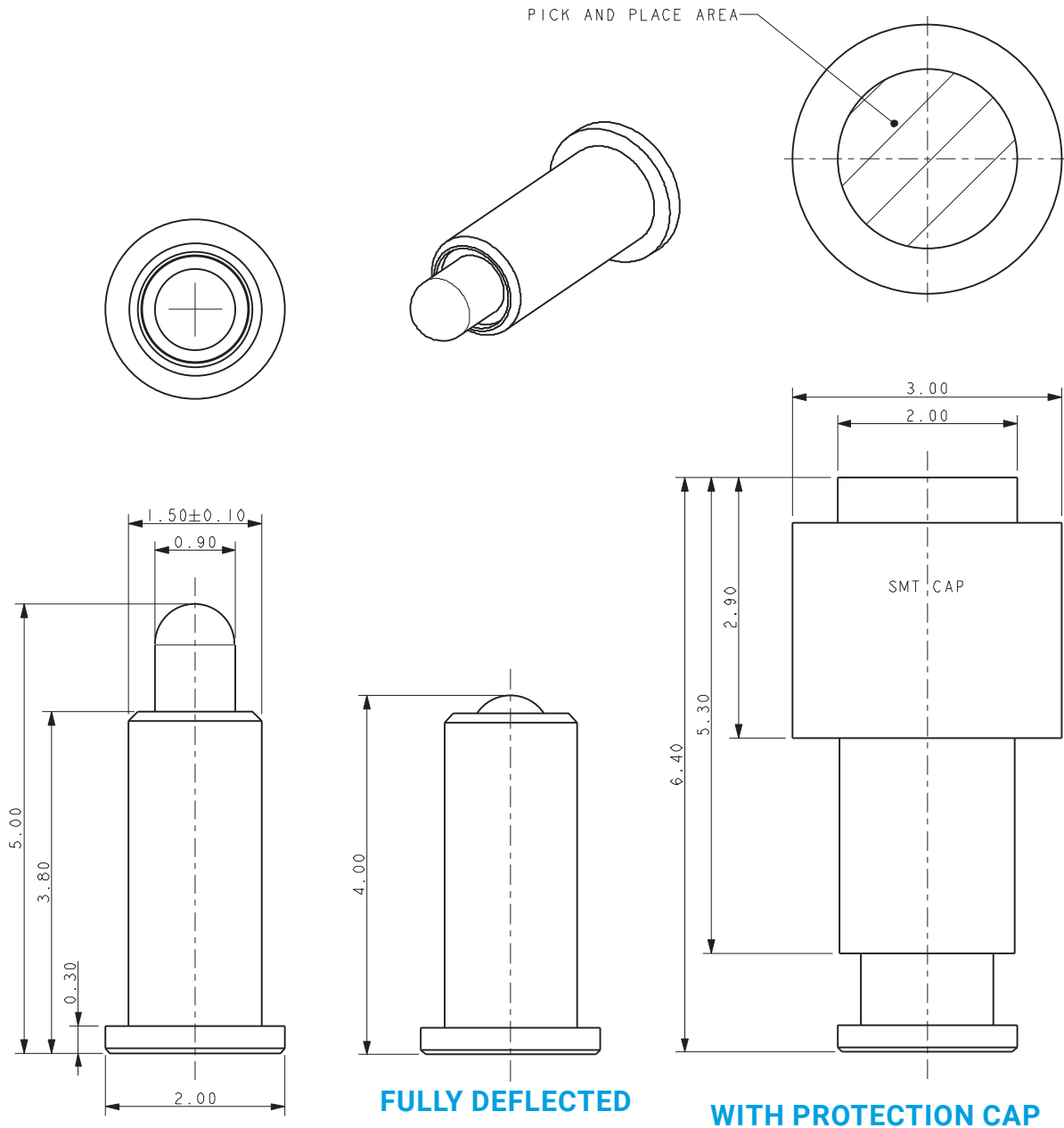

NOTES:

1. SERIES 9150 POGO PIN, WORKING HEIGHT 4MM TO 4.5MM.
2. MATERIAL: PIN AND SLEEVE, COPPER ALLOW PLATED GOLD OVER NICKEL. SPRING STAINLESS STEEL.
3. SUPPLIED WITH A PROTECTION CAP IN PA9T. SUITABLE FOR PICK AND PLACE AND RE-FLOW.
4. PACKING IN TAPE AND REEL, QUANTITY PER REEL 1400.
5. DURABILITY 10,000 OPERATIONS FOR OTHER PRODUCT DETAILS REFER TO SPECIFICATION 201-01-158.
6. GENERAL TOLERANCE ± 0.20 UNLESS STATED.
7. PCB DETAILS ON PAGE 131.

PACKING DETAILS

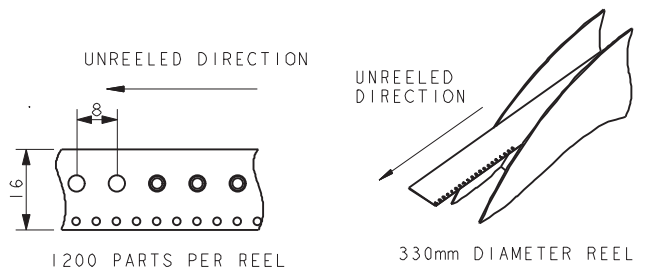

Pogo Pin Single Contact: 70-9150-BTB

5mm High Pin

1.50MM DIAMETER 5MM HIGH POGO PIN

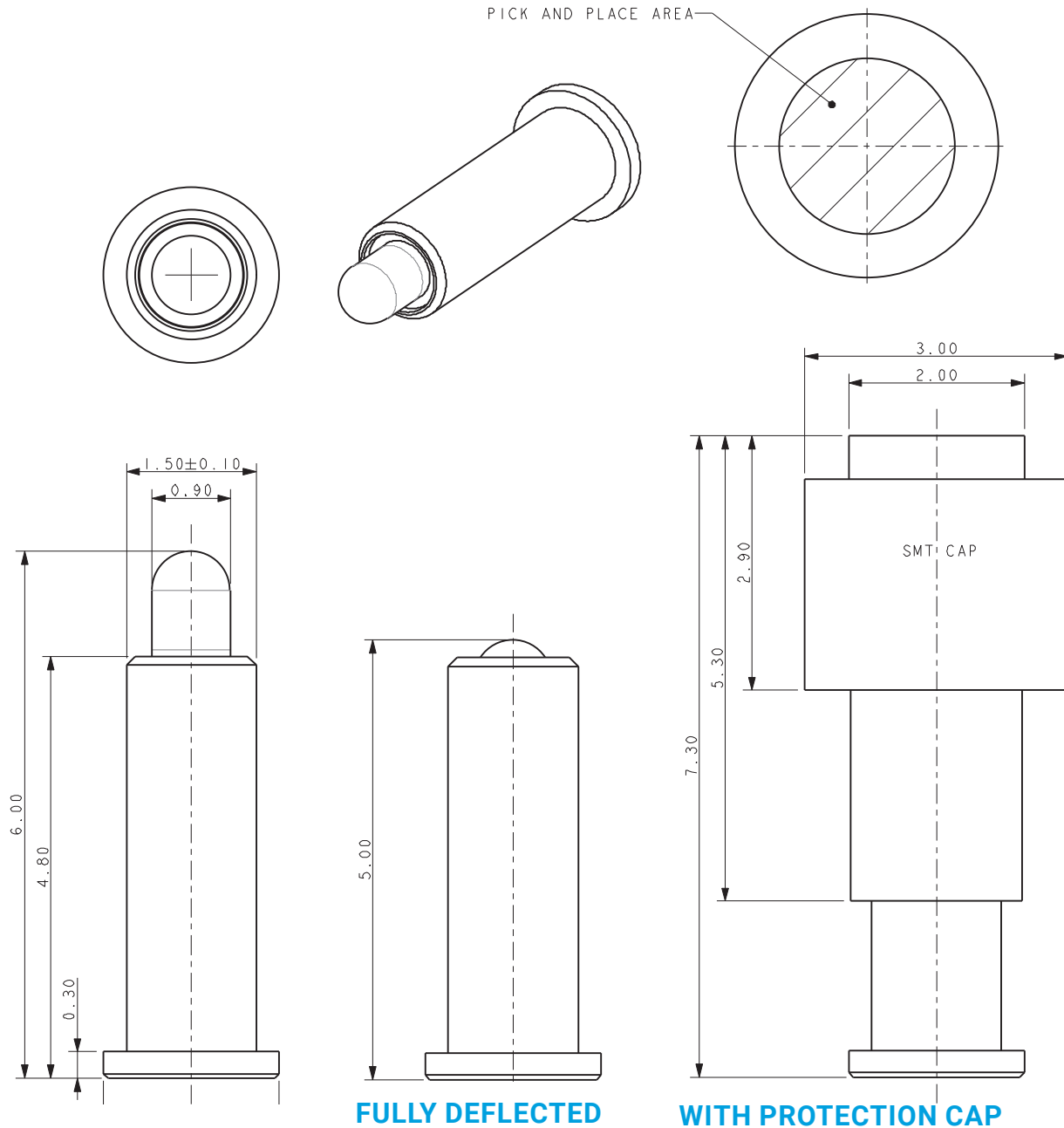

FULLY DEFLECTED

WITH PROTECTION CAP

NOTES:

1. SERIES 9150 POGO PIN, WORKING HEIGHT 5MM TO 5.5MM.
2. MATERIAL: PIN AND SLEEVE, COPPER ALLOW PLATED GOLD OVER NICKEL. SPRING STAINLESS STEEL.
3. SUPPLIED WITH A PROTECTION CAP IN PA9T. SUITABLE FOR PICK AND PLACE AND RE-FLOW.
4. PACKING IN TAPE AND REEL, QUANTITY PER REEL 1400.
5. DURABILITY 10,000 OPERATIONS FOR OTHER PRODUCT DETAILS REFER TO SPECIFICATION 201-01-158.
6. GENERAL TOLERANCE ± 0.20 UNLESS STATED.
7. PCB DETAILS ON PAGE 131.

PACKING DETAILS

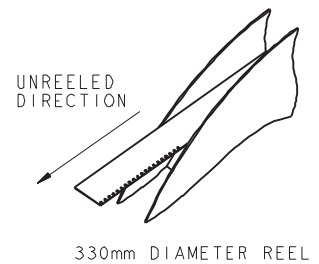
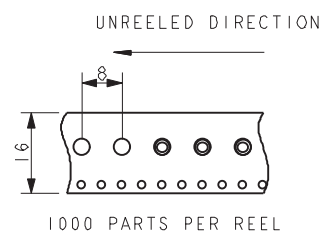

Pogo Pin Single Contact: 70-9150-BTB

PCB Details

PCB DETAILS

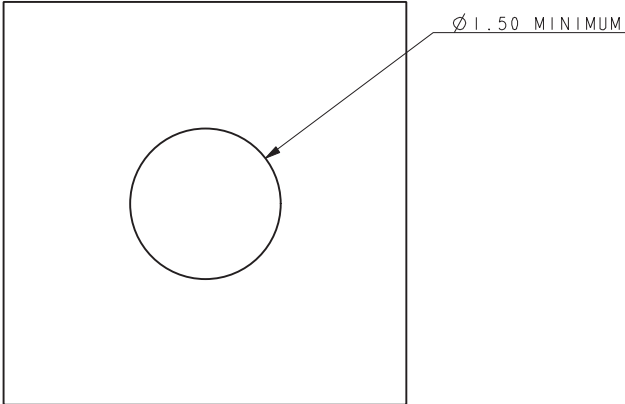

**SUGGESTED MATING PCB
PAD TO BE PLATED GOLD OVER NICKEL**

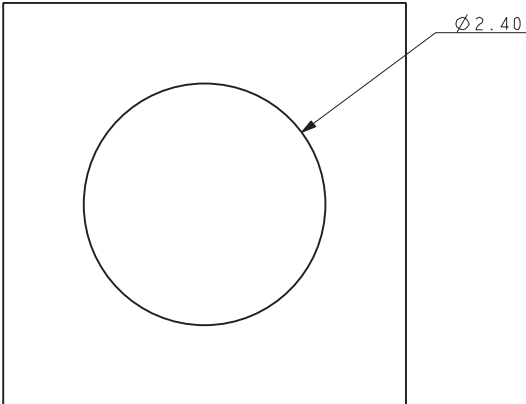

SUGGESTED MOUNTING PCB

Jumper: 10-9296 BTB

General Description

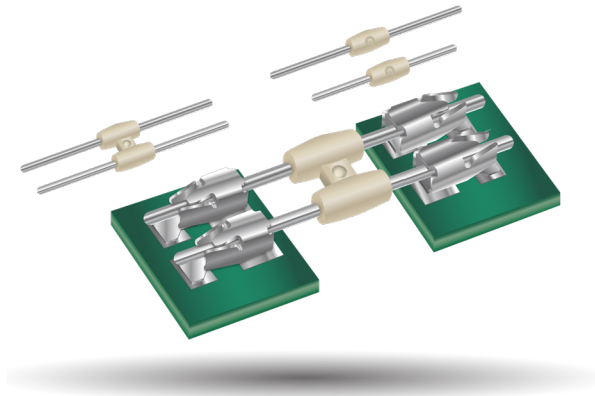

- Multiple jumper pins to be used in linear BTB applications
- 1.0mm pin diameter comes in a 38.15mm and 26mm length
 - 1.0mm pin to be used with 709296001025016
- 0.8mm pin diameter comes in a 16mm length
 - 0.8mm pin to be used with 709296001002016 and the 9296-202 series



APPLICATIONS

- The 709296001025016 and 709296001002016 contacts without a wire stop, allow the pin header to pass straight thru the contacts until the final seating/mating dimension is achieved
- Single pin connection between linear PCB's
- 38mm pin allows for modules to be connected where the PCB is recessed within the plastic housing.

FEATURES AND BENEFITS

- Absorption of PCB and module mating tolerances by allowing the unrestricted pin to pass through the contact by eliminating the traditional wire stop
- Two different pin lengths and pin diameters to accommodate a
- number of board-to-board and module-to-module connections
- The unique geometry of the insulator lends itself to water tightness when matched with a corresponding housing cavity

ELECTRICAL

- Current Rating:
1.0mm Pin Diameter = 6.5A
0.8mm Pin Diameter = 5A
- Voltage Rating:
300V (based on contact spacing)

ENVIRONMENTAL

- Operating Temperature:
-40°C to +105°C

MECHANICAL

- Insulator Material: Glass-Filled Nylon PA-66; UL94V0
- Contact Material: Brass
- Plating: Lead-Free Tin Over Nickel
- Durability: 3 Cycles

HOW TO ORDER

10	9296	00X	XXX	X	X	6
Prefix	Series	Number of Positions	Pin Length 0.8mm Dia. Pin	Housing Color Standard	Pin Size/Spacing	Contact Plating
10 = Plug		001 = 1 pin 002 = 2 pin	160 = 16mm 1.0mm Dia. Pin 260 = 26mm 381 = 38.15mm	9 = White/Natural Special Order 2 = Brown 3 = Blue 4 = Yellow 5 = Red 6 = Green 7 = Orange	Pin diameter/Spacing* 0 = ϕ 1.00 on 4.00mm Pitch 1 = ϕ 0.80 on 3.00mm Pitch	6 = Pure Tin

Certification: UL File #E90723



Jumper: 10-9296 BTB

10-9296-001-XXX-X06 (1.0MM)

Part Number	Dim. A
10-9296-001-260-X06	26.0
10-9296-001-381-X06	38.15

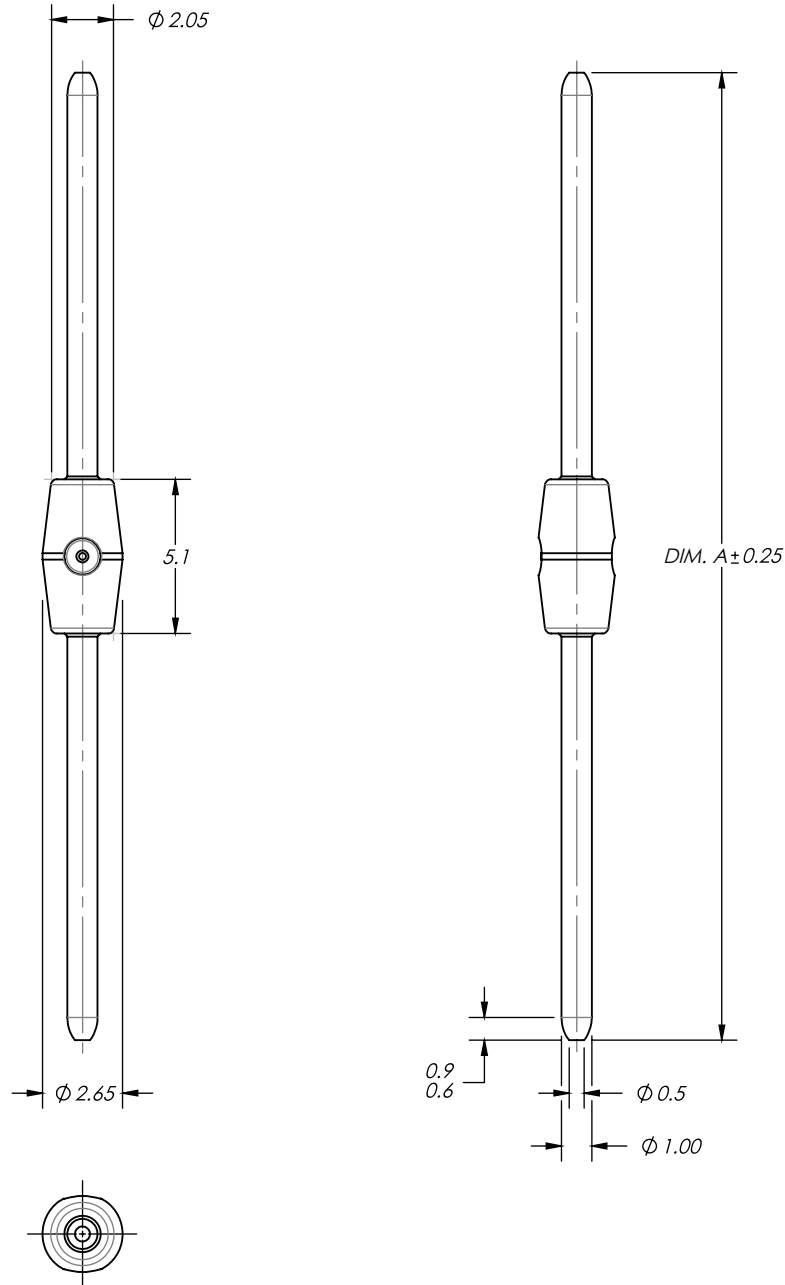

NOTES:

- HOUSING MATERIAL: GLASS-FILLED NYLON; PA-66; FLAME RETARDANT PER UL94V-0; COLOR: PER CODE.
- PIN MATERIAL: BRASS.
- PIN PLATING: LEAD-FREE TIN OVER NICKEL.
- PACKAGING TO BE BULK, 1,000 PER BAG.
- SPECIFICATIONS:
 - CURRENT RATING: 6.5A
 - INSULATION RESISTANCE: 1,000M Ω MINIMUM
 - CONTACT RESISTANCE: 25 Ω MAXIMUM
 - DIELECTRIC WITHSTANDING VOLTAGE: 1,600V AC/DC
 - OPERATING TEMPERATURE: SPEC -40°C TO +125°C - UL RATING UP TO 130°C.

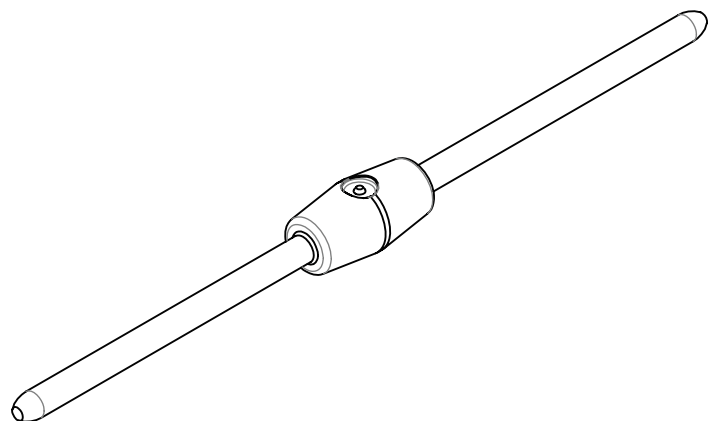

Jumper: 10-9296 BTB

10-9296-002-XXX-X06 (1.0MM)

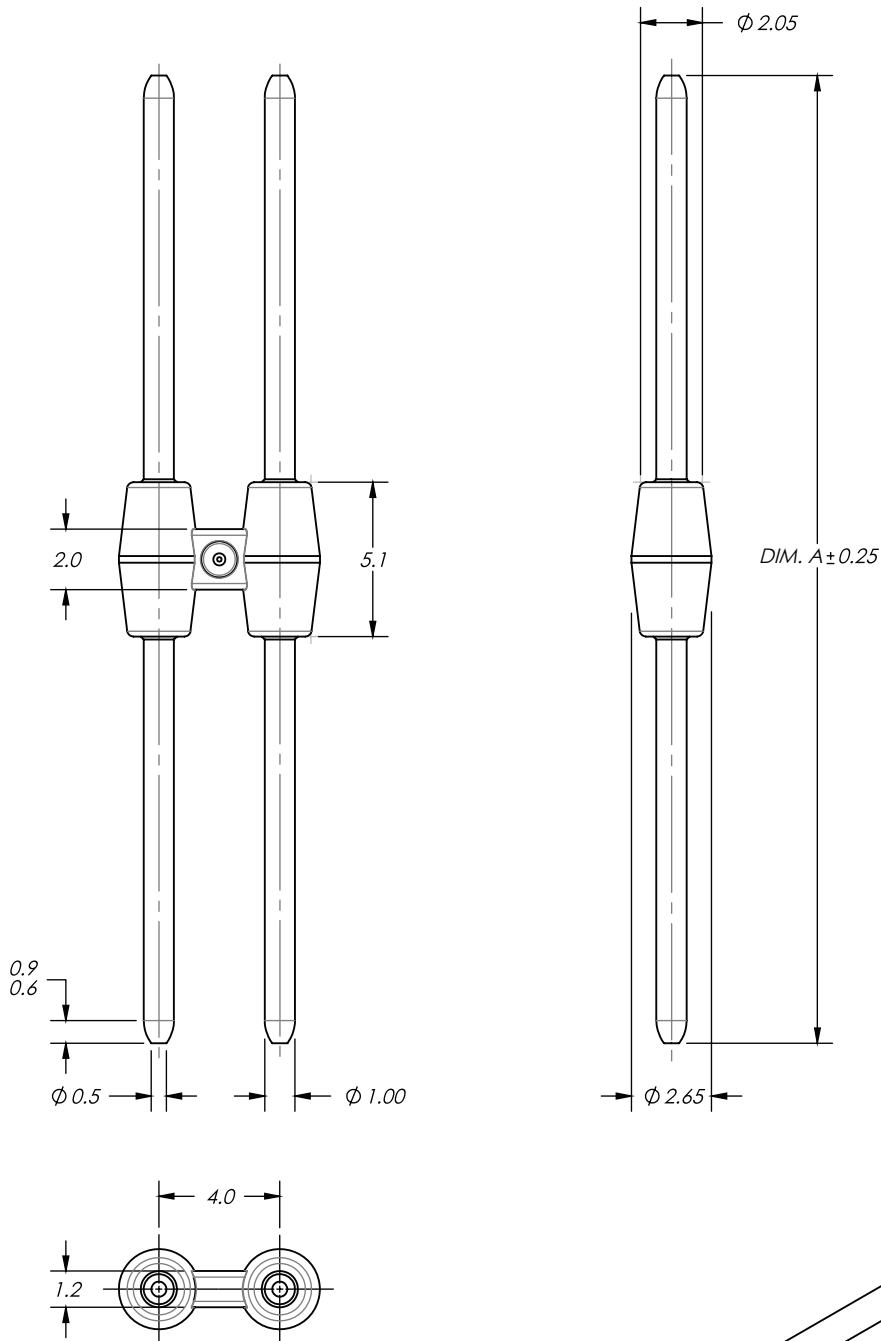

Part Number	Dim. A
10-9296-001-260-906	26.0
10-9296-001-381-906	38.15

NOTES:

1. HOUSING MATERIAL: GLASS-FILLED NYLON; PA-66;
FLAME RETARDANT PER UL94V-0; COLOR: PER CODE.
2. PIN MATERIAL: BRASS.
3. PIN PLATING: LEAD-FREE TIN OVER NICKEL.
4. PACKAGING TO BE BULK, 500 PER BAG.
5. SPECIFICATIONS:
 - CURRENT RATING: 6.5A
 - INSULATION RESISTANCE: 1,000M Ω MINIMUM
 - CONTACT RESISTANCE: 25 Ω MAXIMUM
 - DIELECTRIC WITHSTANDING VOLTAGE: 1,600V AC/DC
 - OPERATING TEMPERATURE: SPEC -40°C TO +125°C - UL RATING UP TO 130°C.

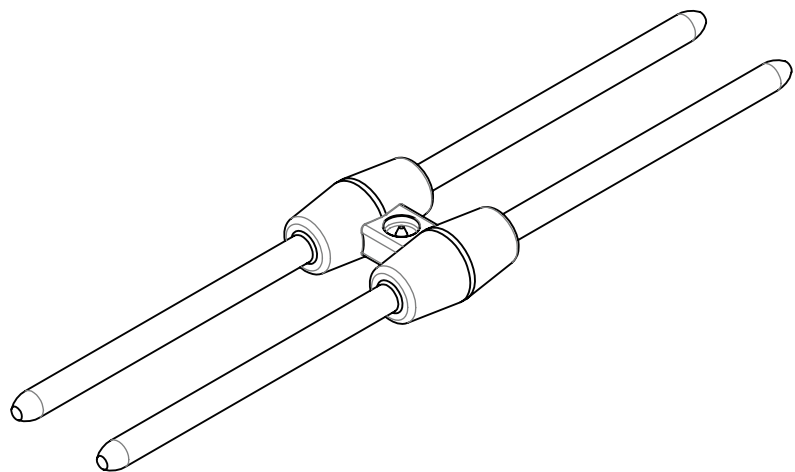

Jumper: 10-9296 BTB

10-9296-001-XXX-X16 (0.8MM)

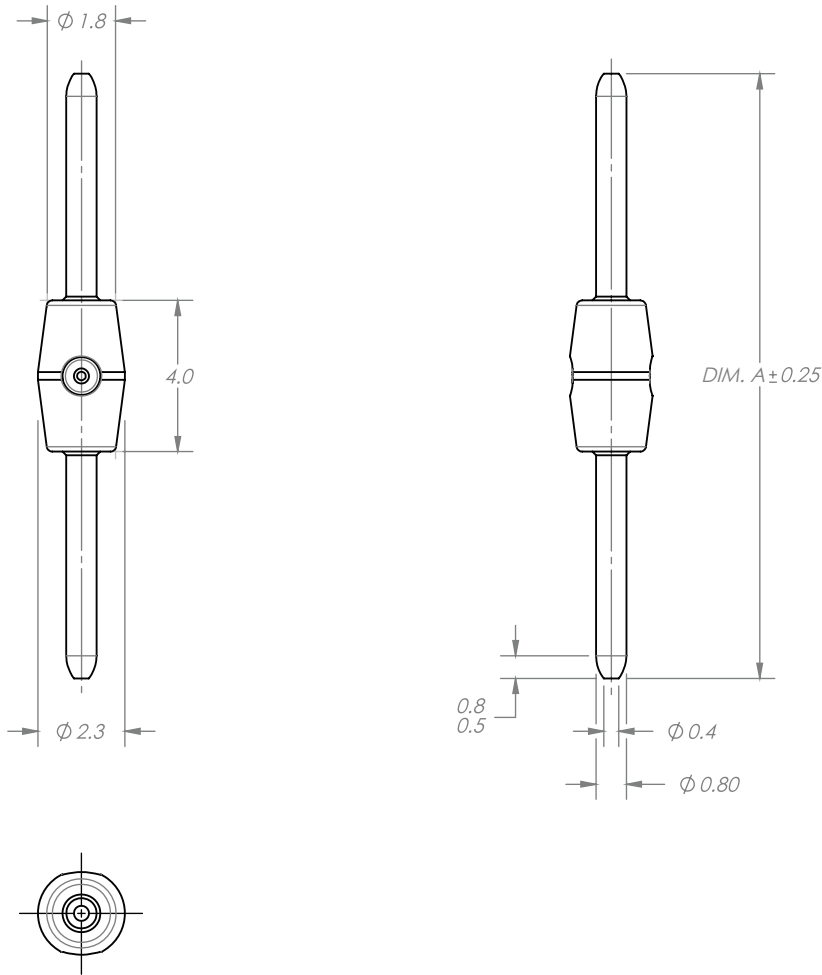

Part Number	Dim. A
10-9296-001-160-X16	26.0
T.B.D.	T.B.D.

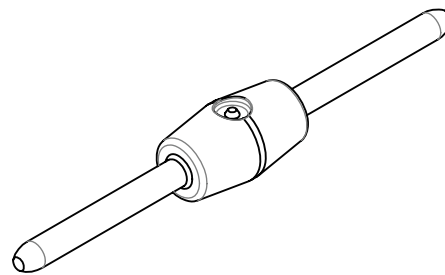

NOTES:

1. HOUSING MATERIAL: GLASS-FILLED NYLON; PA-66;
FLAME RETARDANT PER UL94V-0; COLOR: PER CODE.
2. PIN MATERIAL: BRASS.
3. PIN PLATING: LEAD-FREE TIN OVER NICKEL.
4. PACKAGING TO BE BULK, 1,000 PER BAG.
5. SPECIFICATIONS:
 - CURRENT RATING: 5.0 AMPS
 - INSULATION RESISTANCE: 1,000M Ω MINIMUM
 - CONTACT RESISTANCE: 25 Ω MAXIMUM
 - DIELECTRIC WITHSTANDING VOLTAGE: 1,600V AC/DC
 - OPERATING TEMPERATURE: SPEC -40°C TO +125°C - UL RATING UP TO 130°C.
6. GENERAL TOLERANCE - ± 0.2 .

Jumper: 10-9296 BTB

10-9296-002-XXX-X16 (0.8MM)

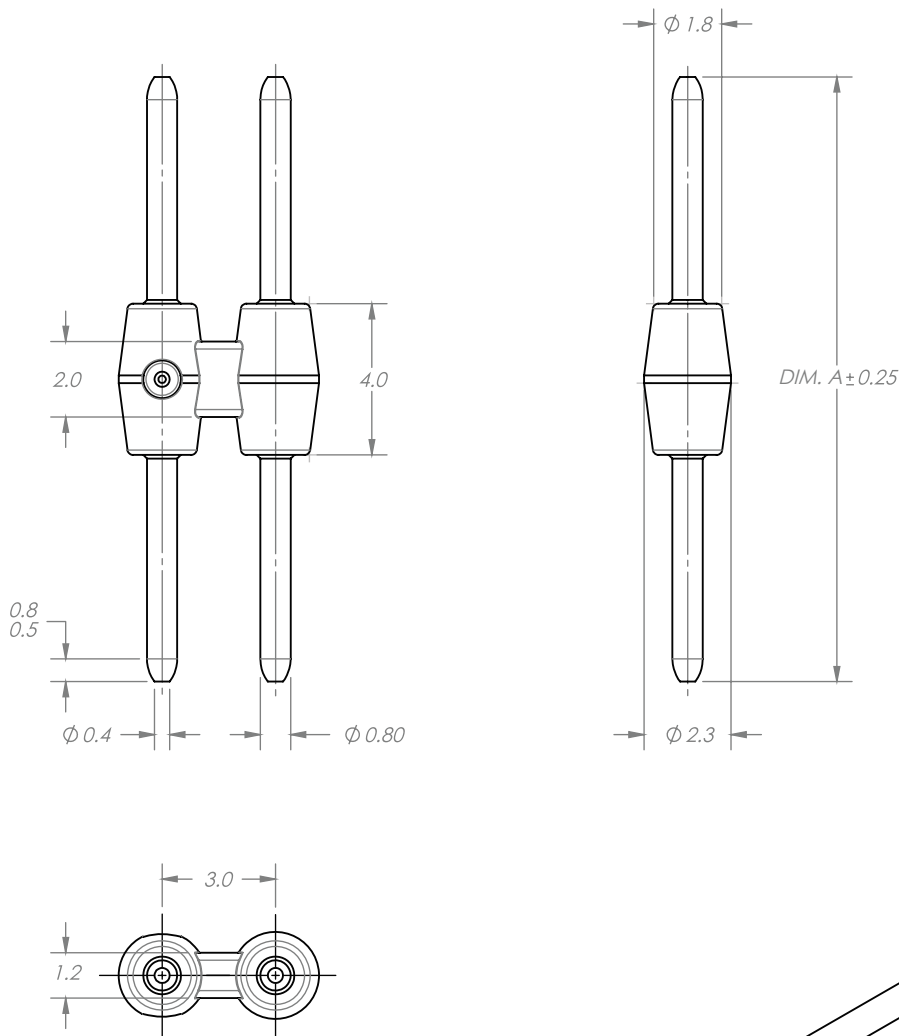

Part Number	Dim. A
10-9296-001-160-X16	16.0
T.B.D.	T.B.D.

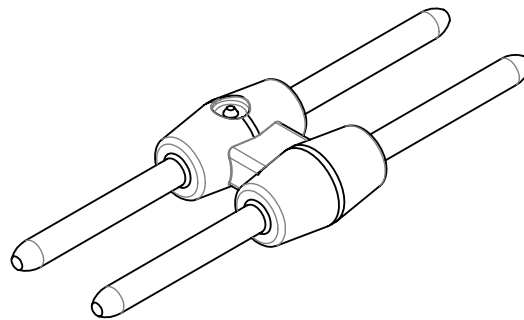

NOTES:

- HOUSING MATERIAL: GLASS-FILLED NYLON; PA-66;
FLAME RETARDANT PER UL94V-0; COLOR: PER CODE.
- PIN MATERIAL: BRASS.
- PIN PLATING: LEAD-FREE TIN OVER NICKEL.
- PACKAGING TO BE BULK, 1,000 PER BAG.
- SPECIFICATIONS:
 - CURRENT RATING: 5.0 AMPS
 - INSULATION RESISTANCE: 1,000M Ω MINIMUM
 - CONTACT RESISTANCE: 25 Ω MAXIMUM
 - DIELECTRIC WITHSTANDING VOLTAGE: 1,600V AC/DC
 - OPERATING TEMPERATURE: SPEC -40°C TO +125°C - UL RATING UP TO 130°C.
- GENERAL TOLERANCE - ± 0.2 .

Linking Contact System: 70-9159 BTB

General Description

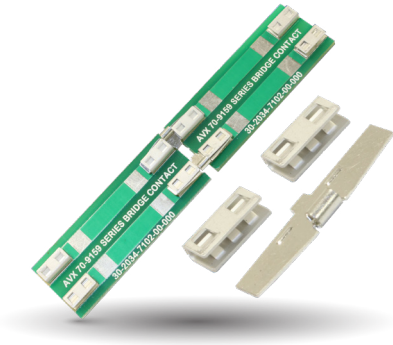

STRIPT™ or naked contacts have been proven to provide high performance at a lower cost structure than traditional insulated connectors. Adding to the list of UL certified contacts already on the market from KYOCERA AVX, the new high spring force “C-Clip” designed SMT contact can be linked together with a bridging contact to provide ultra-reliability in linear BTB connections. In addition to robustness, this three-piece component set absorbs mating tolerances between the boards and can handle 20 amps of continuous current.

APPLICATIONS

- Linear LED Board-to-Board connections
- Co-Planar PCB mating

FEATURES AND BENEFITS

- Fatigue resistant phosphor bronze material which generates and maintains high mating forces
- Integral dimples on the bridge contact provides positive retention in the c-clip contact
- Center placed attachment tang prevents the bridge contact from moving forward or backwards

ELECTRICAL

- Current Rating: 9 Amps
- Voltage Rating: 300V

ENVIRONMENTAL

- Operating Temperature: -40°C to +125°C

MECHANICAL

- Contact Material: Phosphor Bronze
- Plating: Lead-Free Matte Tin Over Nickel
- Durability: 5 Cycles

HOW TO ORDER

70	9159	001	3XX	006
Prefix	Series	Number of Ways 001 = 1	Contact Description 302 = SMT Contact 311 = Bridge Contact	Plating Option 006 = Tin Over Nickel

Архангельск (8182)63-90-72
 Астана (7172)727-132
 Астрахань (8512)99-46-04
 Барнаул (3852)73-04-60
 Белгород (4722)40-23-64
 Брянск (4832)59-03-52
 Владивосток (423)249-28-31
 Волгоград (844)278-03-48
 Вологда (8172)26-41-59
 Воронеж (473)204-51-73
 Екатеринбург (343)384-55-89
 Иваново (4932)77-34-06

Ижевск (3412)26-03-58
 Иркутск (395)279-98-46
 Казань (843)206-01-48
 Калининград (4012)72-03-81
 Калуга (4842)92-23-67
 Кемерово (3842)65-04-62
 Киров (8332)68-02-04
 Краснодар (861)203-40-90
 Красноярск (391)204-63-61
 Курск (4712)77-13-04
 Липецк (4742)52-20-81
 Киргизия (996)312-96-26-47

Магнитогорск (3519)55-03-13
 Москва (495)268-04-70
 Мурманск (8152)59-64-93
 Набережные Челны (8552)20-53-41
 Нижний Новгород (831)429-08-12
 Новокузнецк (3843)20-46-81
 Новосибирск (383)227-86-73
 Омск (3812)21-46-40
 Орел (4862)44-53-42
 Оренбург (3532)37-68-04
 Пенза (8412)22-31-16
 Россия (495)268-04-70

Пермь (342)205-81-47
 Ростов-на-Дону (863)308-18-15
 Рязань (4912)46-61-64
 Самара (846)206-03-16
 Санкт-Петербург (812)309-46-40
 Саратов (845)249-38-78
 Севастополь (8692)22-31-93
 Симферополь (3652)67-13-56
 Смоленск (4812)29-41-54
 Сочи (862)225-72-31
 Ставрополь (8652)20-65-13
 Казахстан (772)734-952-31

Сургут (3462)77-98-35
 Тверь (4822)63-31-35
 Томск (3822)98-41-53
 Тула (4872)74-02-29
 Тюмень (3452)66-21-18
 Ульяновск (8422)24-23-59
 Уфа (347)229-48-12
 Хабаровск (4212)92-98-04
 Челябинск (351)202-03-61
 Череповец (8202)49-02-64
 Ярославль (4852)69-52-93

<https://avx.nt-rt.ru/> || axv@nt-rt.ru

LOW PROFILE HIGH CURRENT SURFACE MOUNT CONTACT

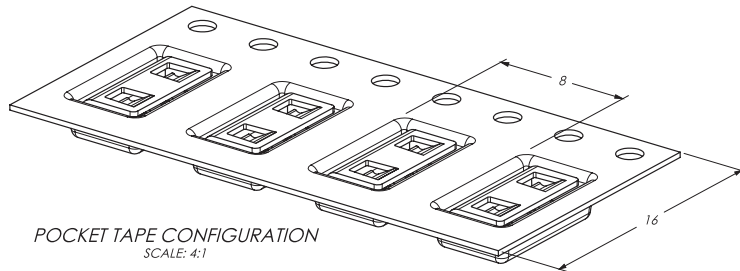

POCKET TAPE CONFIGURATION
SCALE: 4:1

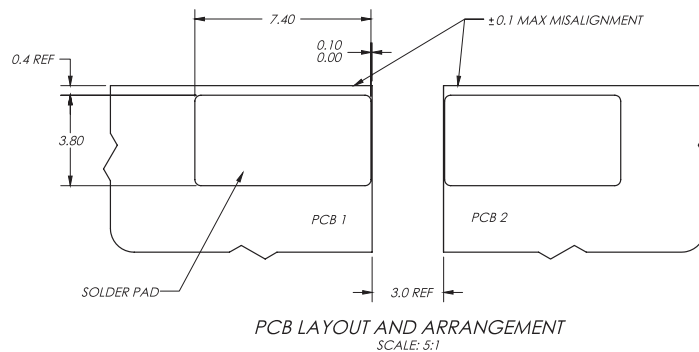
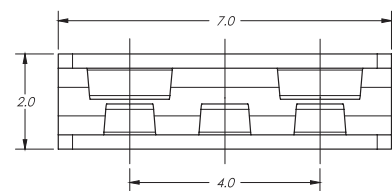
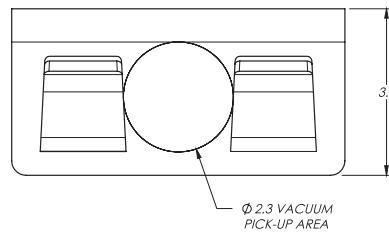
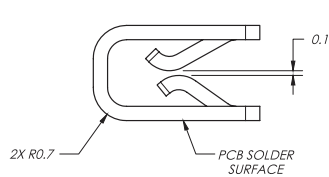
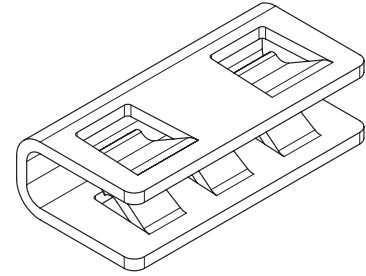

BRIDGE CONTACT 9159 SERIES SPECIAL

