

Архангельск (8182)63-90-72
Астана (7172)727-132
Астрахань (8512)99-46-04
Барнаул (3852)73-04-60
Белгород (4722)40-23-64
Брянск (4832)59-03-52
Владивосток (423)249-28-31
Волгоград (844)278-03-48
Вологда (8172)26-41-59
Воронеж (473)204-51-73
Екатеринбург (343)384-55-89
Иваново (4932)77-34-06

Ижевск (3412)26-03-58
Иркутск (395)279-98-46
Казань (843)206-01-48
Калининград (4012)72-03-81
Калуга (4842)92-23-67
Кемерово (3842)65-04-62
Киров (8332)68-02-04
Краснодар (861)203-40-90
Красноярск (391)204-63-61
Курск (4712)77-13-04
Липецк (4742)52-20-81
Киргизия (996)312-96-26-47

Магнитогорск (3519)55-03-13
Москва (495)268-04-70
Мурманск (8152)59-64-93
Набережные Челны (8552)20-53-41
Нижний Новгород (831)429-08-12
Новокузнецк (3843)20-46-81
Новосибирск (383)227-86-73
Омск (3812)21-46-40
Орел (4862)44-53-42
Оренбург (3532)37-68-04
Пенза (8412)22-31-16
Россия (495)268-04-70

Пермь (342)205-81-47
Ростов-на-Дону (863)308-18-15
Рязань (4912)46-61-64
Самара (846)206-03-16
Санкт-Петербург (812)309-46-40
Саратов (845)249-38-78
Севастополь (8692)22-31-93
Симферополь (3652)67-13-56
Смоленск (4812)29-41-54
Сочи (862)225-72-31
Ставрополь (8652)20-65-13
Казахстан (772)734-952-31

Сургут (3462)77-98-35
Тверь (4822)63-31-35
Томск (3822)98-41-53
Тула (4872)74-02-29
Тюмень (3452)66-21-18
Ульяновск (8422)24-23-59
Уфа (347)229-48-12
Хабаровск (4212)92-98-04
Челябинск (351)202-03-61
Череповец (8202)49-02-64
Ярославль (4852)69-52-93

<https://avx.nt-rt.ru/> || axv@nt-rt.ru



Multilayer Ceramic SMD Feedthru Capacitors

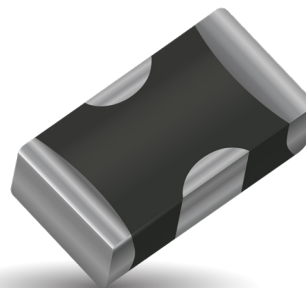
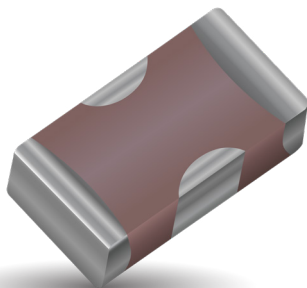

IMPORTANT INFORMATION/DISCLAIMER

All product specifications, statements, information and data (collectively, the “Information”) in this datasheet or made available on the website are subject to change. The customer is responsible for checking and verifying the extent to which the Information contained in this publication is applicable to an order at the time the order is placed. All Information given herein is believed to be accurate and reliable, but it is presented without guarantee, warranty, or responsibility of any kind, expressed or implied.

Statements of suitability for certain applications are based on KYOCERA AVX’s knowledge of typical operating conditions for such applications, but are not intended to constitute and KYOCERA AVX specifically disclaims any warranty concerning suitability for a specific customer application or use.

ANY USE OF PRODUCT OUTSIDE OF SPECIFICATIONS OR ANY STORAGE OR INSTALLATION INCONSISTENT WITH PRODUCT GUIDANCE VOIDS ANY WARRANTY.

The Information is intended for use only by customers who have the requisite experience and capability to determine the correct products for their application. Any technical advice inferred from this Information or otherwise provided by KYOCERA AVX with reference to the use of KYOCERA AVX’s products is given without regard, and KYOCERA AVX assumes no obligation or liability for the advice given or results obtained.

Although KYOCERA AVX designs and manufactures its products to the most stringent quality and safety standards, given the current state of the art, isolated component failures may still occur. Accordingly, customer applications which require a high degree of reliability or safety should employ suitable designs or other safeguards (such as installation of protective circuitry or redundancies) in order to ensure that the failure of an electrical component does not result in a risk of personal injury or property damage.

Unless specifically agreed to in writing, KYOCERA AVX has not tested or certified its products, services or deliverables for use in high risk applications including medical life support, medical device, direct physical patient contact, water treatment, nuclear facilities, weapon systems, mass and air transportation control, flammable environments, or any other potentially life critical uses. Customer understands and agrees that KYOCERA AVX makes no assurances that the products, services or deliverables are suitable for any high-risk uses. Under no circumstances does KYOCERA AVX warrant or guarantee suitability for any customer design or manufacturing process.

Although all product-related warnings, cautions and notes must be observed, the customer should not assume that all safety measures are indicated or that other measures may not be required.

FEEDTHRU 0805/1206 CAPACITORS

Table of Contents

FEEDTHRU 0805/1206 CAPACITORS

W2F/W3F Series, High Current W2H SeriesCommercial, Automotive, High Current, RoHS & SnPb	1
Application Notes	5

FEEDTHRU 0805/1206 CAPACITORS

W2F/W3F Series, High Current W2H Series

Commercial, Automotive, High Current, RoHS & SnPb

GENERAL DESCRIPTION

Available in both a standard 0805 and 1206 size, KYOCERA AVX's line of feedthru capacitors are ideal choices for EMI suppression, broadband I/O filtering, or Vcc power line conditioning. The unique construction of a feedthru capacitor provides low parallel inductance and offers excellent decoupling capability for all high di/dt environments and provides significant noise reduction in digital circuits to <5 GHz. A large range of capacitor values are available in either NP0 or X7R ceramic dielectrics. KYOCERA AVX FeedThru filters are AEC Q200 qualified. High reliability screening options, and SnPb termination are available for spacecraft designs.

W2F/W2H Series 0805



W3F Series 1206



ELECTRICAL PARAMETERS

Type	Case Size (EIA)	Part Number				Capacitance (pF)	Capacitance Tolerance	Rated DC Voltage	Rated Current (Amps)	Dielectric
		Standard	SnPb Termination Finish	Automotive	Automotive w/ SnPb Termination Finish					
High Current	0805	W2H11A2208ATxx	L2H11A2208ABxx	W2H11A22084Txx	L2H11A22084Bxx	22	+50%, -20%	100V	0.5	NP0
	0805	W2H11A4708ATxx	L2H11A4708ABxx	W2H11A47084Txx	L2H11A47084Bxx	47	+50%, -20%	100V	0.5	NP0
	0805	W2H11A1018ATxx	L2H11A1018ABxx	W2H11A10184Txx	L2H11A10184Bxx	100	+50%, -20%	100V	0.5	NP0
	0805	W2H11A2218ATxx	L2H11A2218ABxx	W2H11A22184Txx	L2H11A22184Bxx	220	+50%, -20%	100V	0.5	NP0
	0805	W2H11A4718ATxx	L2H11A4718ABxx	W2H11A47184Txx	L2H11A47184Bxx	470	+50%, -20%	100V	0.5	NP0
	0805	W2H15C1028ATxx	L2H15C1028ABxx	W2H15C10284Txx	L2H15C10284Bxx	1000	+50%, -20%	50V	1.0	X7R
	0805	W2H15C1038ATxx	L2H15C1038ABxx	W2H15C10384Txx	L2H15C10384Bxx	10000	+50%, -20%	50V	1.0	X7R
	0805	W2H15C2238ATxx	L2H15C2238ABxx	W2H15C22384Txx	L2H15C22384Bxx	22000	+50%, -20%	50V	1.0	X7R
	0805	W2H15C4738ATxx	L2H15C4738ABxx	W2H15C47384Txx	L2H15C47384Bxx	47000	+50%, -20%	50V	2.0	X7R
	0805	W2H13C1048ATxx	L2H13C1048ABxx	W2H13C10484Txx	L2H13C10484Bxx	100000	+50%, -20%	25V	2.0	X7R
Standard	0805	W2F11A2208ATxx	L2F11A2208ABxx	W2F11A22084Txx	L2F11A22084Bxx	22	+50%, -20%	100V	0.3	NP0
	0805	W2F11A4708ATxx	L2F11A4708ABxx	W2F11A47084Txx	L2F11A47084Bxx	47	+50%, -20%	100V	0.3	NP0
	0805	W2F11A1018ATxx	L2F11A1018ABxx	W2F11A10184Txx	L2F11A10184Bxx	100	+50%, -20%	100V	0.3	NP0
	0805	W2F11A2218ATxx	L2F11A2218ABxx	W2F11A22184Txx	L2F11A22184Bxx	220	+50%, -20%	100V	0.3	NP0
	0805	W2F11A4718ATxx	L2F11A4718ABxx	W2F11A47184Txx	L2F11A47184Bxx	470	+50%, -20%	100V	0.3	NP0
	0805	W2F15C1028ATxx	L2F15C1028ABxx	W2F15C10284Txx	L2F15C10284Bxx	1000	+50%, -20%	50V	0.3	X7R
	0805	W2F15C2228ATxx	L2F15C2228ABxx	W2F15C22284Txx	L2F15C22284Bxx	2200	+50%, -20%	50V	0.3	X7R
	0805	W2F15C4728ATxx	L2F15C4728ABxx	W2F15C47284Txx	L2F15C47284Bxx	4700	+50%, -20%	50V	0.3	X7R
	0805	W2F15C1038ATxx	L2F15C1038ABxx	W2F15C10384Txx	L2F15C10384Bxx	10000	+50%, -20%	50V	0.3	X7R
	0805	W2F15C2238ATxx	L2F15C2238ABxx	W2F15C22384Txx	L2F15C22384Bxx	22000	+50%, -20%	50V	0.3	X7R
	0805	W2F15C4738ATxx	L2F15C4738ABxx	W2F15C47384Txx	L2F15C47384Bxx	47000	+50%, -20%	50V	0.3	X7R
	1206	W3F11A2208ATxx	L3F11A2208ABxx	W3F11A22084Txx	L3F11A22084Bxx	22	+50%, -20%	100V	0.3	NP0
	1206	W3F11A4708ATxx	L3F11A4708ABxx	W3F11A47084Txx	L3F11A47084Bxx	47	+50%, -20%	100V	0.3	NP0
	1206	W3F11A1018ATxx	L3F11A1018ABxx	W3F11A10184Txx	L3F11A10184Bxx	100	+50%, -20%	100V	0.3	NP0
	1206	W3F11A2218ATxx	L3F11A2218ABxx	W3F11A22184Txx	L3F11A22184Bxx	220	+50%, -20%	100V	0.3	NP0
	1206	W3F11A4718ATxx	L3F11A4718ABxx	W3F11A47184Txx	L3F11A47184Bxx	470	+50%, -20%	100V	0.3	NP0
	1206	W3F15C1028ATxx	L3F15C1028ABxx	W3F15C10284Txx	L3F15C10284Bxx	1000	+50%, -20%	50V	0.3	X7R
	1206	W3F15C2228ATxx	L3F15C2228ABxx	W3F15C22284Txx	L3F15C22284Bxx	2200	+50%, -20%	50V	0.3	X7R
	1206	W3F15C4728ATxx	L3F15C4728ABxx	W3F15C47284Txx	L3F15C47284Bxx	4700	+50%, -20%	50V	0.3	X7R
	1206	W3F15C1038ATxx	L3F15C1038ABxx	W3F15C10384Txx	L3F15C10384Bxx	10000	+50%, -20%	50V	0.3	X7R
1206	W3F15C2238ATxx	L3F15C2238ABxx	W3F15C22384Txx	L3F15C22384Bxx	22000	+50%, -20%	50V	0.3	X7R	
1206	W3F15C4738ATxx	L3F15C4738ABxx	W3F15C47384Txx	L3F15C47384Bxx	47000	+50%, -20%	50V	0.3	X7R	

xx = Packaging and quantity code - see "How To Order" section.

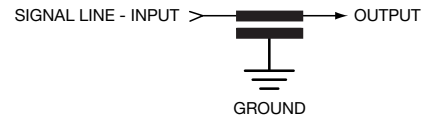

Parameter	High Current	Standard
Insulation Resistance (Minimum)	1000 MΩ	1000 MΩ
DC Resistance	<0.15 Ω	<0.60 Ω
Operating Temperature	-55C to +125C	

HOW TO ORDER

W	3	F	1	5	C	223	8	A	T	3	A
Style	Size	Feedthru	Number of Elements	Voltage	Dielectric	Capacitance Code	Capacitance Tolerance	Failure Rate	Termination	Packaging Code (Reel Size)	Quantity Code (Pcs./Reel)
W = Plated Ni & Sn L = Plated SnPb	2 = 0805 3 = 1206	F = Feedthru H = High Current Feedthru		1 = 100V 5 = 50V 3 = 25V	A = NP0 C = X7R		8 = +50/-20%	A = Not Applicable 4 = AUTOMOTIVE	T = Plated Ni&Sn B* = Plated SnPb *Not RoHS Compliant	1 = 7" Reel A = 2,000 3 = 13" Reel Embossed Tape	F = 1,000 A = 2,000 4,000 or 10,000

FEEDTHRU 0805/1206 CAPACITORS

W2F/W3F Series, High Current W2H Series

Commercial, Automotive, High Current, RoHS & SnPb

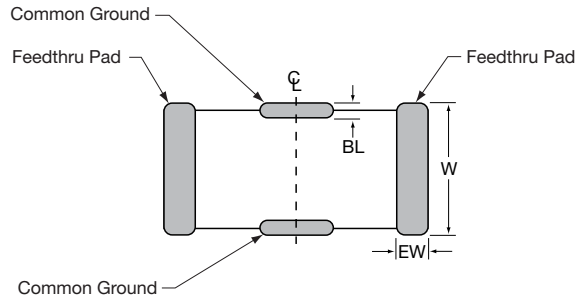
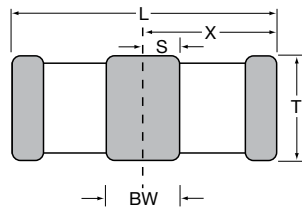

DIMENSIONS

	L	W	T	BW	BL	EW	X	S
0805 MM (in.)	2.01 ± 0.20 (0.079 ± 0.008)	1.25 ± 0.20 (0.049 ± 0.008)	1.14 Max. (0.045 Max.)	0.46 ± 0.10 (0.018 ± 0.004)	0.18 + 0.25 - 0.08 (0.007 + 0.010 - 0.003)	0.25 ± 0.13 (0.010 ± 0.005)	1.02 ± 0.10 (0.040 ± 0.004)	0.23 ± 0.15 (0.009 ± 0.006)
1206 MM (in.)	3.20 ± 0.20 (0.126 ± 0.008)	1.60 ± 0.20 (0.063 ± 0.008)	1.27 Max. (0.050 Max.)	0.89 ± 0.10 (0.035 ± 0.004)	0.18 + 0.25 - 0.08 (0.007 + 0.010 - 0.003)	0.38 ± 0.18 (0.015 ± 0.007)	1.60 ± 0.10 (0.063 ± 0.004)	0.46 ± 0.15 (0.018 ± 0.006)

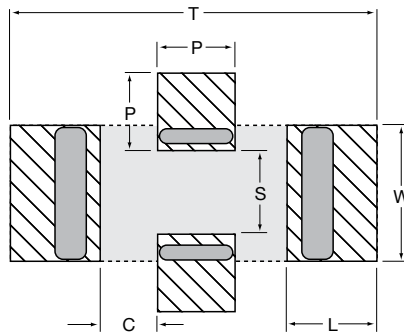

RECOMMENDED SOLDER PAD LAYOUT (TYPICAL DIMENSIONS)

	T	P	S	W	L	C
0805 MM (in.)	3.45 (0.136)	0.51 (0.020)	0.76 (0.030)	1.27 (0.050)	1.02 (0.040)	0.46 (0.018)
1206 MM (in.)	4.54 (0.179)	0.94 (0.037)	1.02 (0.040)	1.65 (0.065)	1.09 (0.043)	0.71 (0.028)

TYPICAL FEEDTHRU CHIP CAP CONNECTION

Feedthru Chip Component Model

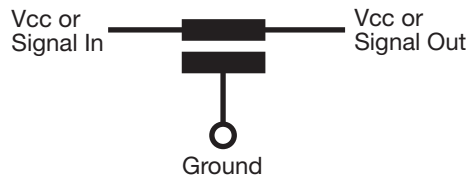

Physical Layout - A

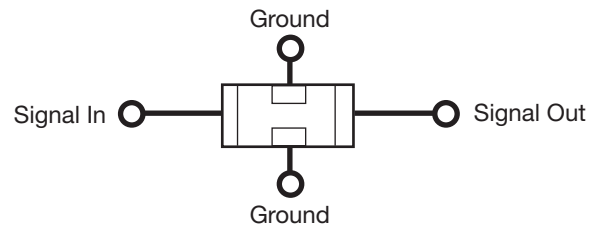

Physical Layout - B

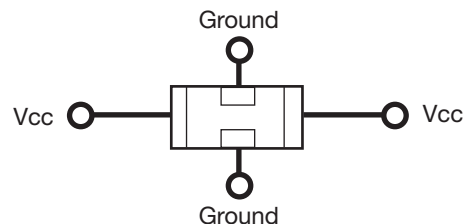

The terminals are connected internally side to side. Left side and right side are connected and front and back are connected internally.

For Decoupling, the chip is usually surrounded by four vias, two for Vcc and two for GND.

For Signal Filtering, the in and out lines need to be separated on the circuit board.

FEEDTHRU 0805/1206 CAPACITORS

W2F/W3F Series, High Current W2H Series

Commercial, Automotive, High Current, RoHS & SnPb

PERFORMANCE CHARACTERISTICS

S21 0805 – 100V

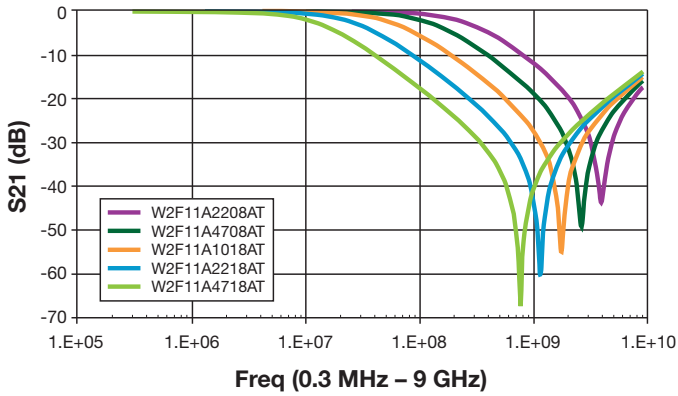

IMPEDANCE 0805 – 100V

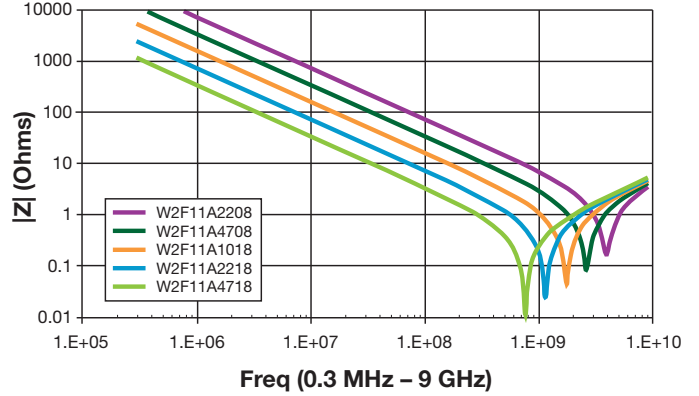

S21 1206 – 100V

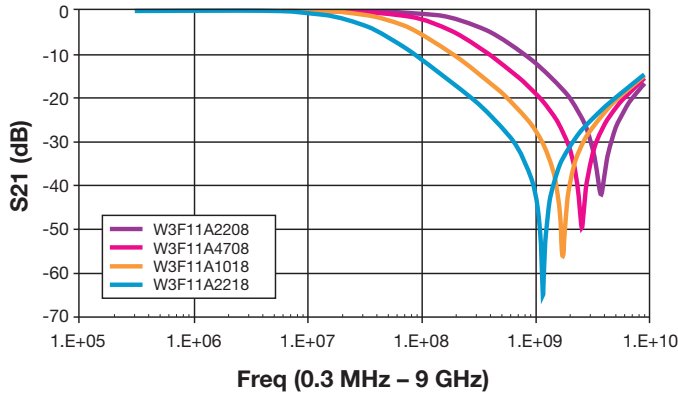

IMPEDANCE 1206 – 100V

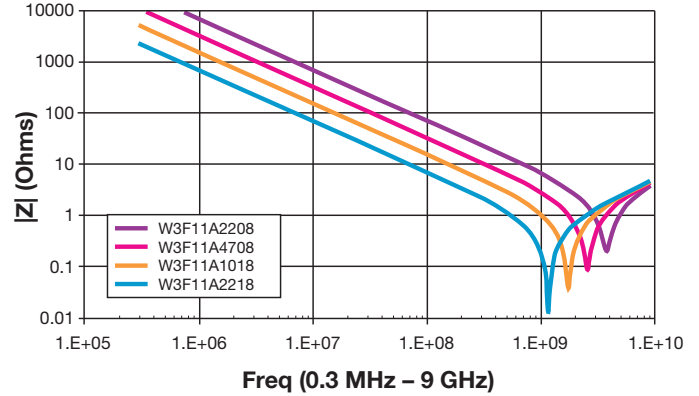

S21 1206 – 50V

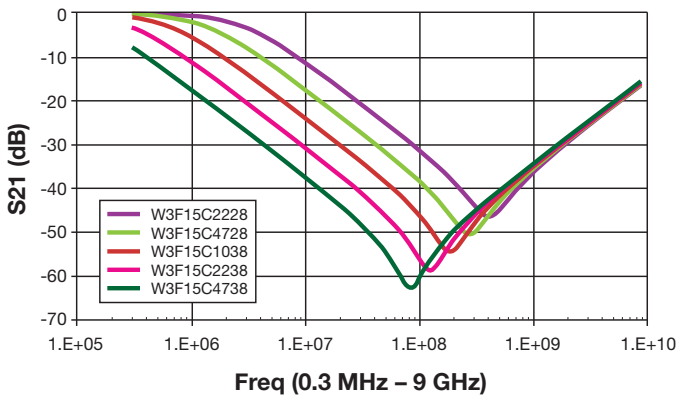

IMPEDANCE 1206 – 50V

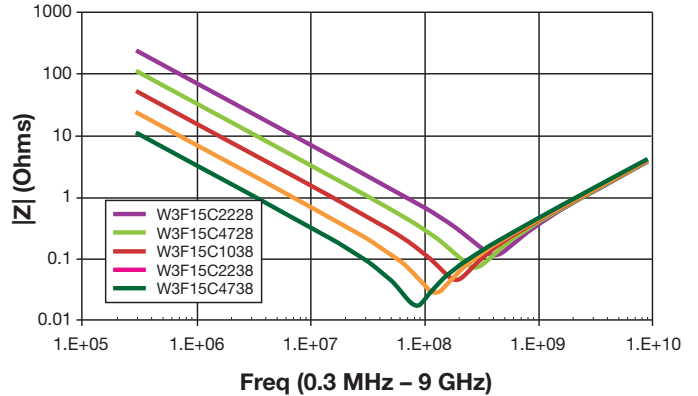

FEEDTHRU 0805/1206 CAPACITORS

W2F/W3F Series, High Current W2H Series

Commercial, Automotive, High Current, RoHS & SnPb

PERFORMANCE CHARACTERISTICS

0805 NPO
Current vs. Temperature

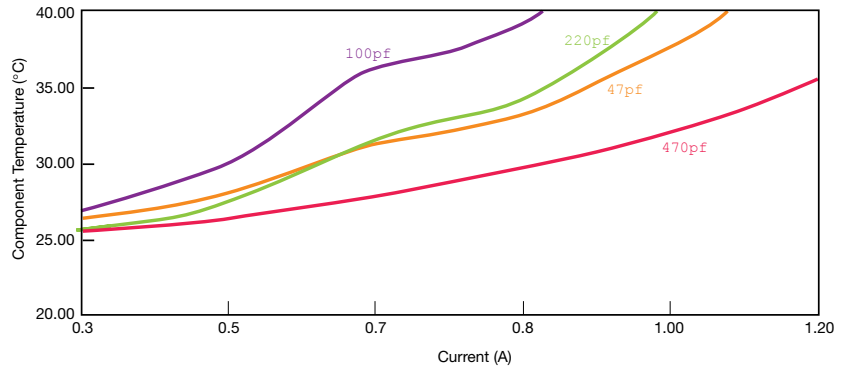

0805 X7R
Current vs. Temperature

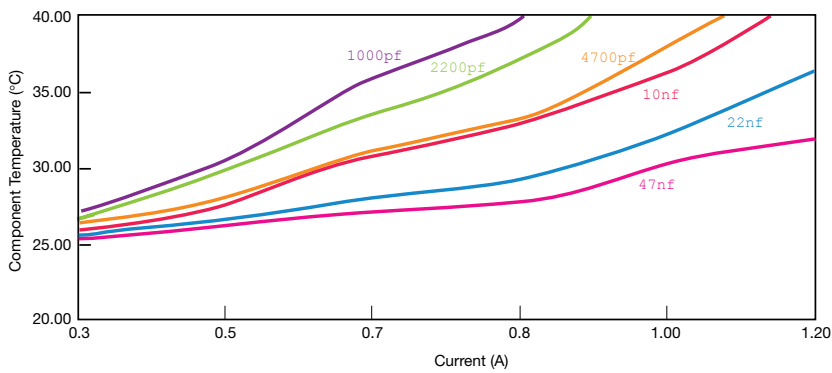

1206 NPO
Current vs. Temperature

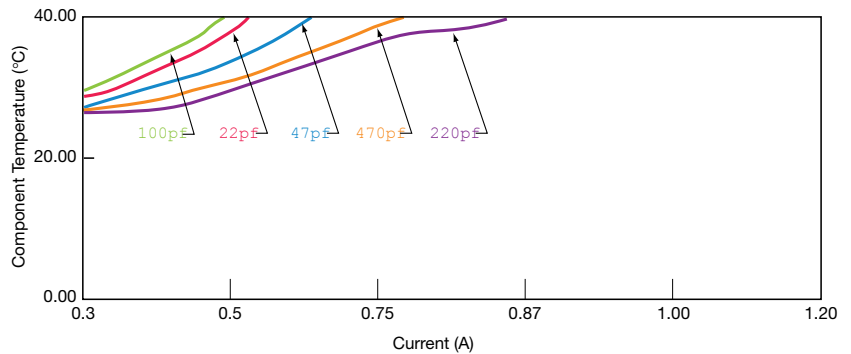

1206 X7R
Current vs. Temperature

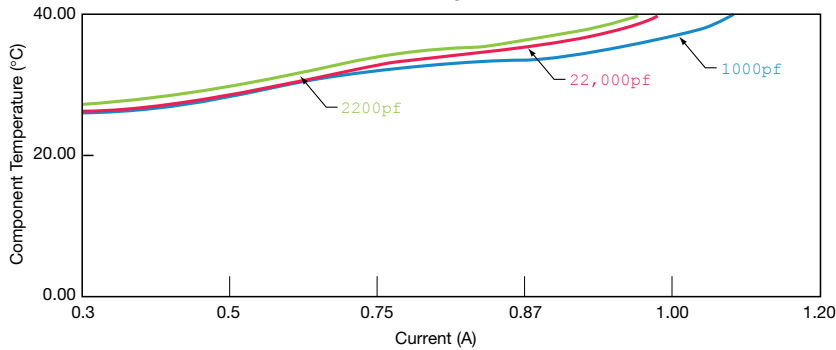

FEEDTHRU 0805/1206 CAPACITORS

Application Notes – W2F/W3F Series

Applications

APPLICATIONS

- EMI Suppression
- Broadband I/O Filtering
- Vcc Line Conditioning

FEATURES

- Standard EIA Sizes
- Broad Frequency Response
- Low ESR
- 8 mm Tape and Reel

MARKET SEGMENTS

- Computers
- Automotive
- Power Supplies
- Multimedia Add-On Cards
- Bar Code Scanners and Remote Terminals
- PCMCIA Cards
- Medical Instrumentation
- Test Equipment
- Transceivers/Cell Phones

Typical Circuits Requiring EMI Filtering

THE FOLLOWING APPLICATIONS AND SCHEMATIC DIAGRAMS SHOW WHERE FEEDTHRU CAPACITORS MIGHT BE USED FOR EMI SUPPRESSION

- Digital to RF Interface Filtering
- Voltage Conditioning in RF Amplifiers
- Power Decoupling GaAs FET Transistor Preamplifier
- Vcc Line Filtering on Frequency Control Circuit
- Clock, Data, Control Line High Frequency Decoupling (Frequency Synthesizer)
(SEE APPLICATION NOTES)

DIGITAL TO RF INTERFACE FILTERING

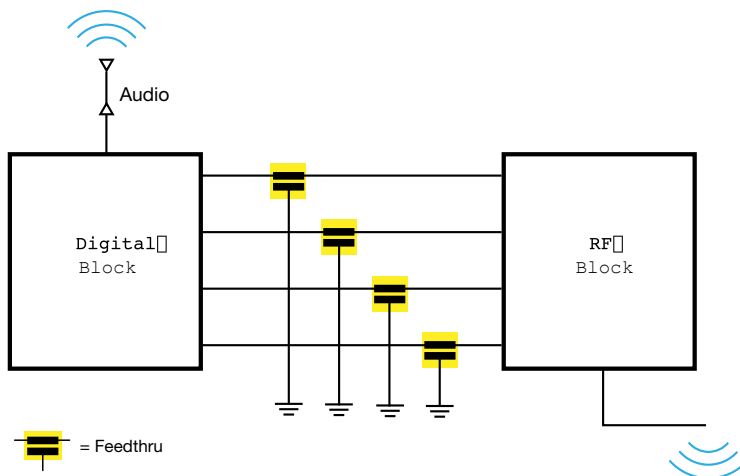

FEEDTHRU 0805/1206 CAPACITORS

W2F/W3F Series

VOLTAGE CONDITIONING IN RF AMPLIFIERS

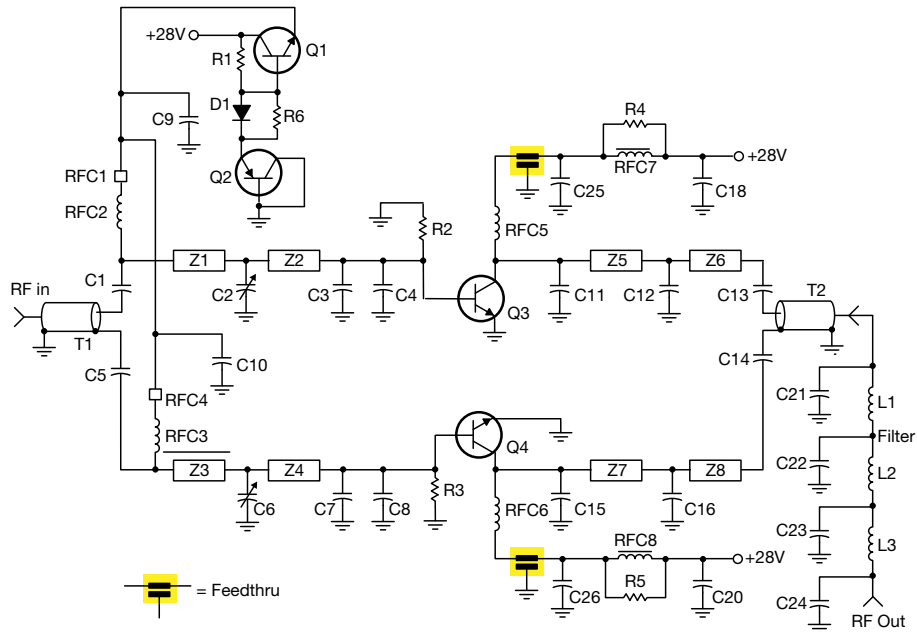

POWER DECOUPLING GAAS FET TRANSISTOR PREAMPLIFIER

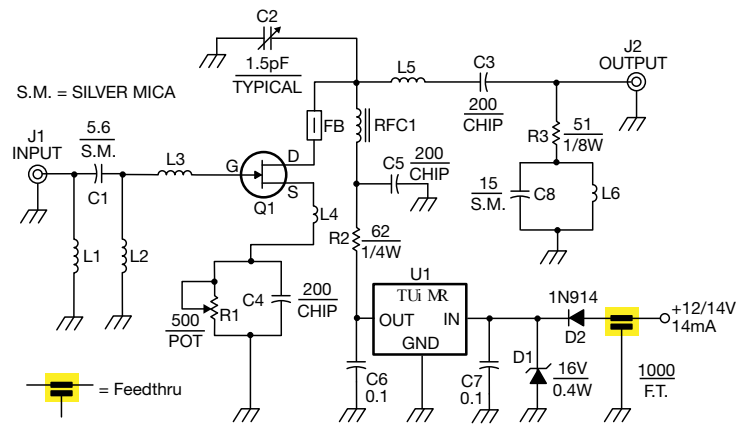

VCC LINE FILTERING ON FREQUENCY CONTROL CIRCUIT

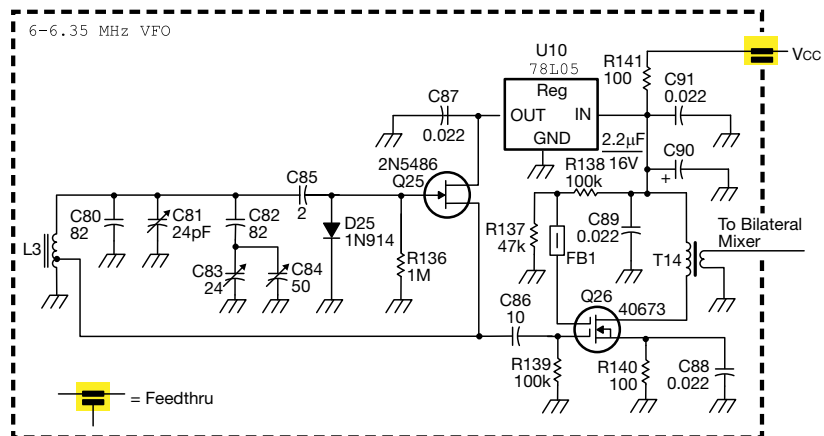

FEEDTHRU 0805/1206 CAPACITORS

W2F/W3F Series

APPLICATIONS

Dual Power Switch Filtering

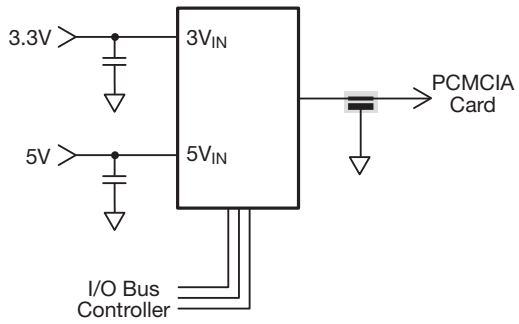

PA Filtering

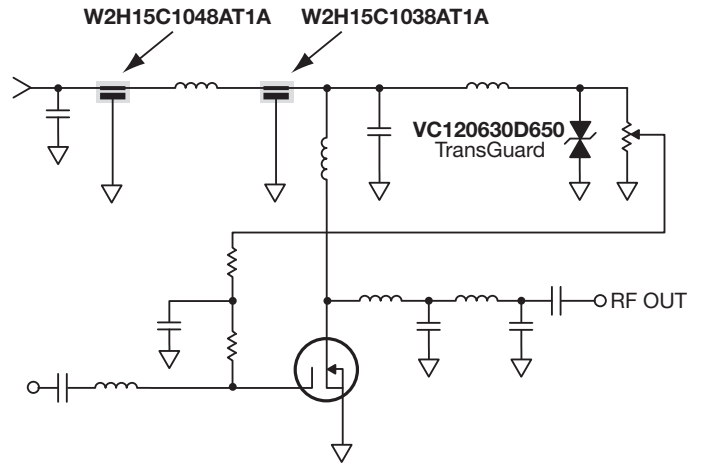

FEEDTHRU 0805/1206 CAPACITORS

W2F/W2H/W3F Series

EMI REDUCTION THROUGH THE USE OF SMT FEEDTHRU CAPACITORS

ABSTRACT

Today's high speed, miniaturized semiconductors have made EMI issues a key design consideration. This paper briefly defines EMI and illustrates the capability of SMT feedthru capacitors.

WHAT IS EMI?

The term EMI stands for Electromagnetic Interference and refers to signals/energy interfering with a circuit or systems functions.

In an electronic system, two classes of energy are generated - wanted and unwanted. Both are potential sources of EMI. Wanted signals such as clocks and bus lines could cause EMI if they were not decoupled, terminated or filtered properly. Unwanted signals (cell phones, police radios, power supply noise, etc.) could be conducted or radiated into the circuit due to poor circuit layout, improper decoupling or a lack of high frequency filtering.

In either type of EMI signal interference, the system could be rendered useless or put into a state which would cause early failure of its semiconductors. Even worse, the unwanted energy could cause an incorrect answer to be generated from a computer by randomly powering a gate up or down. From all of this we can gather that EMI is a complex problem, usually with no one solution. EMI interference can be a random single shot noise (like a SCR firing) or repetitive in nature (stepper motor or relay noise). The interference can enter into our designs either by being induced by E/B fields, or it can be conducted through control lines or a communication bus. EMI can even be self generated by internal components that generate steep risetime waveforms of voltage or current.

HOW CAN EMI BE CONTROLLED?

EMI is most efficiently controlled by realizing it to be a design parameter in the earliest stages of the design. This way, the board layout can be optimized with large power and ground planes which will be low impedance in nature. The use of SMT feedthru filters will yield optimal results.

SMT FEEDTHRU CAPACITORS

KYOCERA AVX introduced feedthru capacitors to supply a broadband EMI filter capacitor for source suppression and receiver noise reduction.

SMT feedthru capacitors use the same material systems as standard ceramic capacitors. They exhibit the same reliability and can be processed in the same end user production methods as

standard capacitors. What feedthru capacitors offer is an optimized frequency response across a wide RF spectrum due to a modified internal electrode design.

An application comparison between an SMT feedthru and a discrete capacitor is shown in Figure 1.

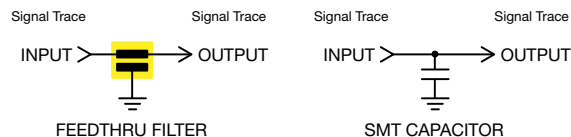

Figure 1. Comparison of Feedthru Capacitors to Discrete Capacitors

The key difference between the two filtering methods is that the feedthru has a much lower inductance between the signal line and ground than the capacitor. The difference in inductances can be in the range of roughly one order magnitude with a feedthru capacitor. This inductance can be shown in an electrical sense through the model for a feedthru and a capacitor (Figure 2).

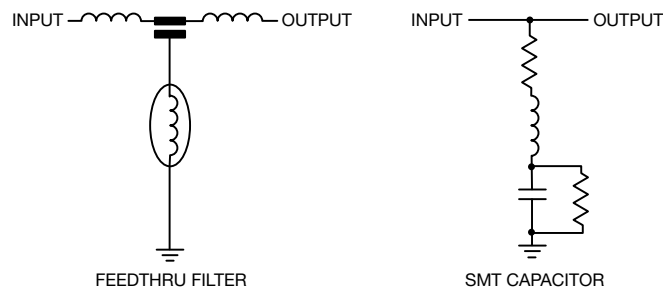

Figure 2. Comparison of Feedthru Capacitors to Discrete Capacitors

The feedthru capacitor has a minimized parallel inductance and an optimal series inductance (which broadens the frequency response curve). Typical attenuation graphs are shown in Figure 3A.

These curves demonstrate feedthru capacitors advantage of a broad frequency response with high attenuation. They also serve as a comparison to the inductance of even lower inductance devices (primarily used in extreme decoupling cases and switch mode power supplies) - see Figure 3B.

(1) Practical Design for Electromagnetic Compatibility edited by Rocco F. Ficchi
Hayden Book Company 1978

FEEDTHRU 0805/1206 CAPACITORS

W2F/W2H/W3F Series

W3F15C2228AT High Frequency Analysis

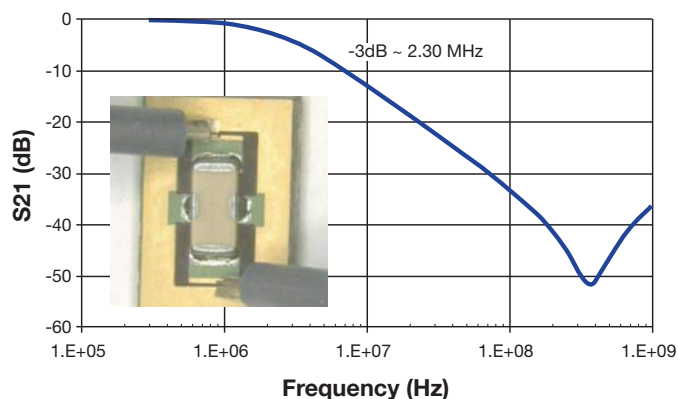

Figure 3A. Typical Attenuation Graph

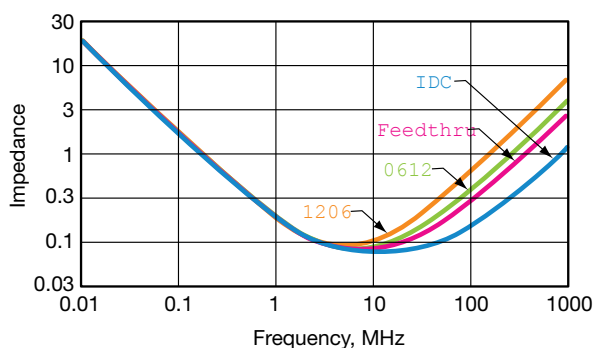

Figure 3B. Comparison of SMT Capacitor Frequency Response to Feedthru Filters

SMT FEEDTHRU CAPACITOR TERMINOLOGY

KYOCERA AVX's feedthru capacitors have additional technical terminologies relative to standard ceramic capacitors. The reason for this is due to the series manner in which the feedthru element is connected to the circuit.

The most important term is DC Resistance. The DC resistance of the feedthru is specified since it causes a minor signal attenuation which designers can calculate by knowing the maximum resistance of the part.

The maximum current capability of the part is also of interest to designers since the feedthru may be placed in series with the voltage line.

APPLICATION AND SELECTION OF SMT FEEDTHRU CAPACITOR FILTERS

EMI suppression and receiver noise reduction can be achieved most effectively with efficient filtering methods. Attenuations of over 100 dB are achievable depending on the complexity and size of the filters involved.

However, before filtering is discussed, another EMI reduction method is noise limiting, using a series element (inductors or resistors). This method is easy to implement and inexpensive. The problem it poses is that it can only reduce noise by -3 to -10 dB. Because of that, series element EMI reduction is primarily used where there is a poor ground.

SMT feedthru filter capacitors can actually replace discrete L/C filter networks (depending on the frequency response needed). The SMT filter capacitors should first be chosen for its specific frequency response. Then the voltage rating, DCR, and current capability must be evaluated for circuit suitability. If there is not a match on voltage, current and DC resistance ratings, the designer must select the closest available frequency response available on parts that will meet the design's power spec.

The top 5 applications for SMT feedthru filter capacitors are:

1. Digital to RF interface filtering.
2. Control line high frequency decoupling.
3. Data and clock high frequency decoupling.
4. Power line high frequency decoupling.
5. High gain and RF amplifier filtering.

Архангельск (8182)63-90-72
 Астана (7172)727-132
 Астрахань (8512)99-46-04
 Барнаул (3852)73-04-60
 Белгород (4722)40-23-64
 Брянск (4832)59-03-52
 Владивосток (423)249-28-31
 Волгоград (844)278-03-48
 Вологда (8172)26-41-59
 Воронеж (473)204-51-73
 Екатеринбург (343)384-55-89
 Иваново (4932)77-34-06

Ижевск (3412)26-03-58
 Иркутск (395)279-98-46
 Казань (843)206-01-48
 Калининград (4012)72-03-81
 Калуга (4842)92-23-67
 Кемерово (3842)65-04-62
 Киров (8332)68-02-04
 Краснодар (861)203-40-90
 Красноярск (391)204-63-61
 Курск (4712)77-13-04
 Липецк (4742)52-20-81
 Киргизия (996)312-96-26-47

Магнитогорск (3519)55-03-13
 Москва (495)268-04-70
 Мурманск (8152)59-64-93
 Набережные Челны (8552)20-53-41
 Нижний Новгород (831)429-08-12
 Новокузнецк (3843)20-46-81
 Новосибирск (383)227-86-73
 Омск (3812)21-46-40
 Орел (4862)44-53-42
 Оренбург (3532)37-68-04
 Пенза (8412)22-31-16
 Россия (495)268-04-70

Пермь (342)205-81-47
 Ростов-на-Дону (863)308-18-15
 Рязань (4912)46-61-64
 Самара (846)206-03-16
 Санкт-Петербург (812)309-46-40
 Саратов (845)249-38-78
 Севастополь (8692)22-31-93
 Симферополь (3652)67-13-56
 Смоленск (4812)29-41-54
 Сочи (862)225-72-31
 Ставрополь (8652)20-65-13
 Казахстан (772)734-952-31

Сургут (3462)77-98-35
 Тверь (4822)63-31-35
 Томск (3822)98-41-53
 Тула (4872)74-02-29
 Тюмень (3452)66-21-18
 Ульяновск (8422)24-23-59
 Уфа (347)229-48-12
 Хабаровск (4212)92-98-04
 Челябинск (351)202-03-61
 Череповец (8202)49-02-64
 Ярославль (4852)69-52-93

<https://avx.nt-rt.ru/> || avx@nt-rt.ru