

Архангельск (8182)63-90-72  
 Астана (7172)727-132  
 Астрахань (8512)99-46-04  
 Барнаул (3852)73-04-60  
 Белгород (4722)40-23-64  
 Брянск (4832)59-03-52  
 Владивосток (423)249-28-31  
 Волгоград (844)278-03-48  
 Вологда (8172)26-41-59  
 Воронеж (473)204-51-73  
 Екатеринбург (343)384-55-89  
 Иваново (4932)77-34-06

Ижевск (3412)26-03-58  
 Иркутск (395)279-98-46  
 Казань (843)206-01-48  
 Калининград (4012)72-03-81  
 Калуга (4842)92-23-67  
 Кемерово (3842)65-04-62  
 Киров (8332)68-02-04  
 Краснодар (861)203-40-90  
 Красноярск (391)204-63-61  
 Курск (4712)77-13-04  
 Липецк (4742)52-20-81  
 Киргизия (996)312-96-26-47

Магнитогорск (3519)55-03-13  
 Москва (495)268-04-70  
 Мурманск (8152)59-64-93  
 Набережные Челны (8552)20-53-41  
 Нижний Новгород (831)429-08-12  
 Новокузнецк (3843)20-46-81  
 Новосибирск (383)227-86-73  
 Омск (3812)21-46-40  
 Орел (4862)44-53-42  
 Оренбург (3532)37-68-04  
 Пенза (8412)22-31-16  
 Россия (495)268-04-70

Пермь (342)205-81-47  
 Ростов-на-Дону (863)308-18-15  
 Рязань (4912)46-61-64  
 Самара (846)206-03-16  
 Санкт-Петербург (812)309-46-40  
 Саратов (845)249-38-78  
 Севастополь (8692)22-31-93  
 Симферополь (3652)67-13-56  
 Смоленск (4812)29-41-54  
 Сочи (862)225-72-31  
 Ставрополь (8652)20-65-13  
 Казахстан (772)734-952-31

Сургут (3462)77-98-35  
 Тверь (4822)63-31-35  
 Томск (3822)98-41-53  
 Тула (4872)74-02-29  
 Тюмень (3452)66-21-18  
 Ульяновск (8422)24-23-59  
 Уфа (347)229-48-12  
 Хабаровск (4212)92-98-04  
 Челябинск (351)202-03-61  
 Череповец (8202)49-02-64  
 Ярославль (4852)69-52-93

<https://avx.nt-rt.ru/> || [avx@nt-rt](mailto:avx@nt-rt)

## Part No. ETH-LORA-M-AX-01

### LoRa Module

868 / 915 MHz

Supports: Light Sensors, Home Lighting, Smart Door Locks, Water Meters, Parking Sensors, Smart City, Smart Retail

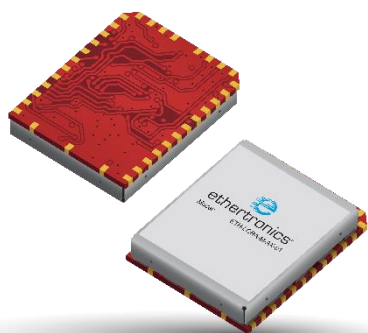

Ethertronics' LoRa Module ETH-LORA-M-AX-01 is an SMT mounted cost efficient and low power radio module that operates in the unlicensed 868/915 MHz bands. It combines a LoRa™ transceiver SX1272 of Semtech Corporation [1] with Ethertronics chipset and technologies to maximize the link budget and RF performance. A sensitivity of up to -138 dBm and a maximum output power of +19 dBm results in a link budget of more than 156 dB. The increase in the link budget results in much longer range and robustness without the need for additional components.

### ETH-LORA-M-AX-01 LoRa Module

868 MHz / 915 MHz

#### KEY BENEFITS

##### Antenna Impedance Matching Capability

LoRa module embedding Impedance Matching chipset and algorithm to maximize the power transfer between the radio and the antenna

##### Ethertronics Active Steering™ Ready

LoRa module embedding Ethertronics patented MCD algorithm and capable of driving Ethertronics Active Steering™ antennas

#### APPLICATIONS

- Smart metering
- Smart grids
- Smart city
- Telemetry
- IoT

#### Real-World Performance and Implementation

Designed for global market, pre-certified Ethertronics' ETH-LORA-M-AX-01 helps reducing time consuming for radio development and related costs. Compared to other available modules in the market, ETH-LORA-M-AX-01 is embedded with proprietary Impedance Matching and Active Steering™ capabilities to optimize the RF performance on its own in order to achieve an excellent ultra-long range spread spectrum communication.

ETH-LORA-M-AX-01 is designed with power saving techniques so that the current consumption is low even when in communication.

Fast time-to-market is also possible with two types of demo boards (Active/Passive) equipped with high performance antennas provided by Ethertronics.

The wide range functionalities of ETH-LORA-M-AX-01 can be tested conveniently.

#### Simplified Diagram

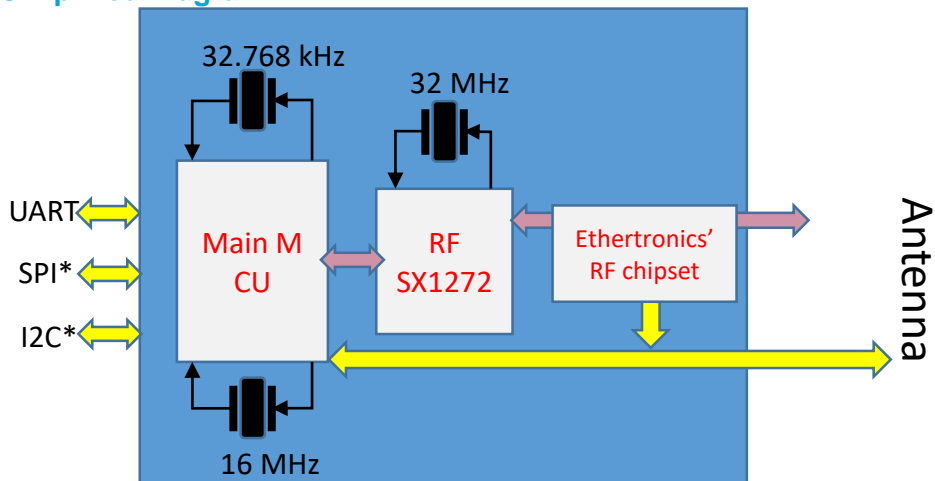

\* UART interface is available now. SPI and I2C are coming soon with Firmware Update

LoRa Module specifications  
 Ethertronics produces a wide variety of standard and custom antennas to meet user needs

**Absolute Maximum Rating**

Parameter	Min	Typ	Max	Unit
Supply Voltage (Vdd)	0	-	3.9	V
Storage Temperature	-40	-	85	°C
Operating Temperature	-40	-	85	°C
Max input Power	-	-	10	dBm
ESD	-	2000	-	V

**Global Electrical Parameters**

Parameter	Min	Typ	Max	Unit
Supply Voltage (Vdd)	2.5	3.0	3.6	V
Current Consumption Stop mode with RTC	-	1.8	-	µA
Current Consumption Sleep mode	-	3	-	mA
Current Consumption Run mode	-	9	-	mA
Current Consumption TX mode	-	100	-	mA
Current Consumption RX Mode	-	20	-	mA

**RF Transmitter Characteristic**

Parameter	Condition	Min	Typical	Max	Unit
Frequency		863	-	915	MHz
RF Output	868 MHz	-	14	-	dBm
	915 MHz	-	19	-	dBm
Modulation Techniques		LoRa™			
TX Frequency Variation vs. Temperature	-40 to +85°C	-	±10	-	kHz
TX Power Variation vs. Temperature		-	±0.5	-	dB

**LoRa Module specifications**  
 Ethertronics produces a wide variety of standard and custom antennas to meet user needs

**Module Interface Specifications**

All I/Os are CMOS and TTL compliant.

Symbol	Parameter	Condition	Min	Max	Unit
$V_{IL}$	Input low level voltage	$2.5 < VDD < 3.6$	-	$0.3VDD$	V
$V_{IH}$	Input high level voltage	$2.5 < VDD < 3.6$ Standard	$0.45$ $VDD+0.38$	-	
		$2.5 < VDD < 3.6$ Tolerant 5V	$0.39$ $VDD+0.59$	-	
$V_{OL}$	Output low level voltage	$2.7 V < VDD < 3.6 V$ Sink/source up to 8mA		$0.4$	
$V_{OH}$	Output high level voltage		$VDD-0.4$		
$V_{OL}$	Output low level voltage	$2.7 V < VDD < 3.6 V$ Sink/source up to 4mA		$0.45$	
$V_{OH}$	Output high level voltage		$VDD-0.45$		

For the current firmware version, ETH-LORA-M-AX-01 supports UART to interface with the host using AT commands. The UART interface consists of only two lines RXD (input) and TXD (output) thus simplify the connection with the host. To save power consumption, this module support low power mode: Deep Sleep and Stop. In deep sleep mode, the module can wake up from UART command, while in stop mode the wake-up pin (P11) must be connected to the RX line of this module on the user's PCB, so that the character sent by user can wake up the module. Please refer to document about the integration guideline [\[2\]](#) and at command [\[3\]](#) for more details.

UART Interface setup:

Parameter	Default Value
Baud rate	115200
Data length	8 bits
Parity	None
Stop bit	1 bit
Flow control	None

LoRa Module specifications  
 Ethertronics produces a wide variety of standard and custom antennas to meet user needs

Block diagram of the module used with a passive antenna

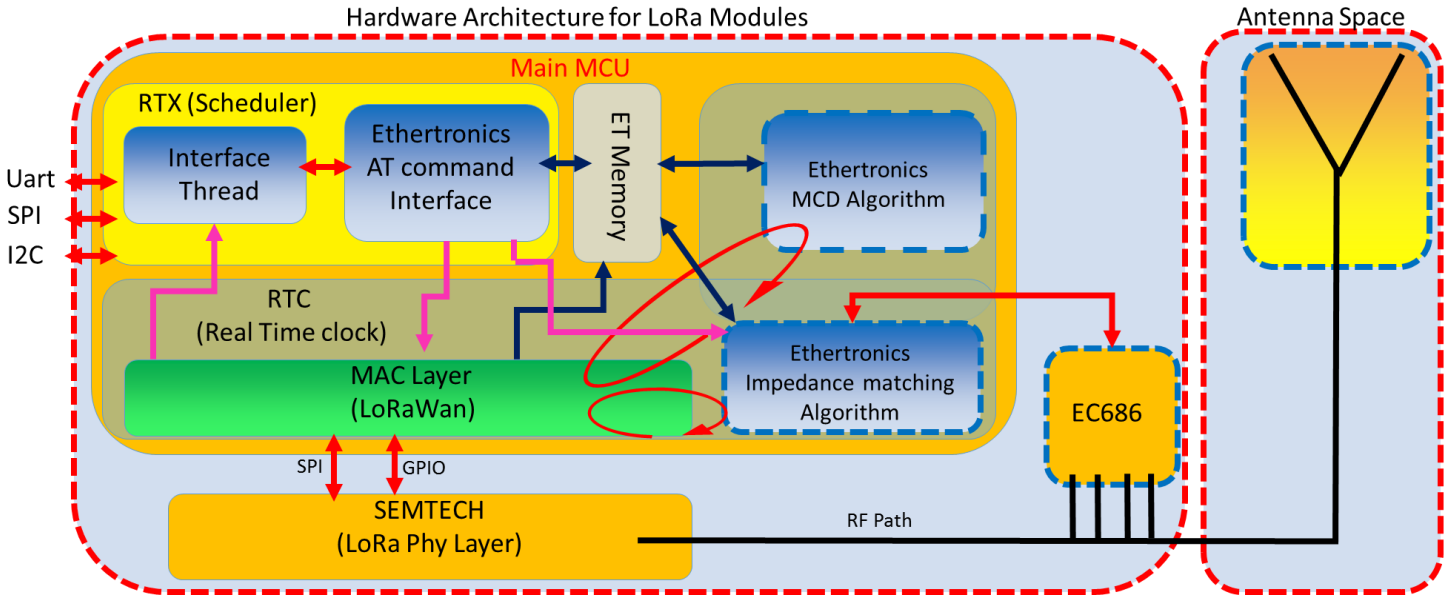

In this configuration, a proprietary impedance matching algorithm helps to maximize the power transfer to the antenna. Please refer to the application note about the passive evaluation board for more details [4].

Block diagram of the module used with an Ethertronics Active Steering™ antenna

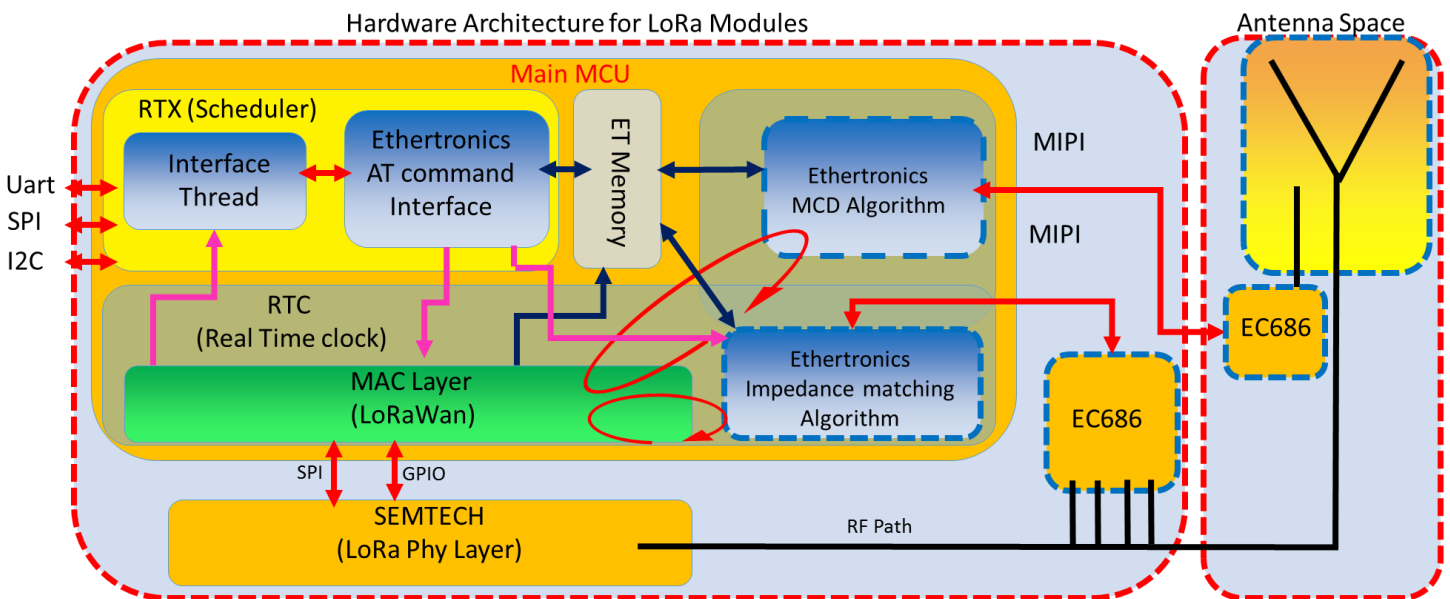

In this configuration, an active antenna with several radiation patterns must be used. In addition to the impedance matching algorithm, the MCD algorithm helps to choose the best radiation pattern regardless to the change of environment. Please refer to the application note about the active evaluation board for more details [5].

LoRa Module specifications

Ethertronics produces a wide variety of standard and custom antennas to meet user needs

Pin Diagram (Top View)

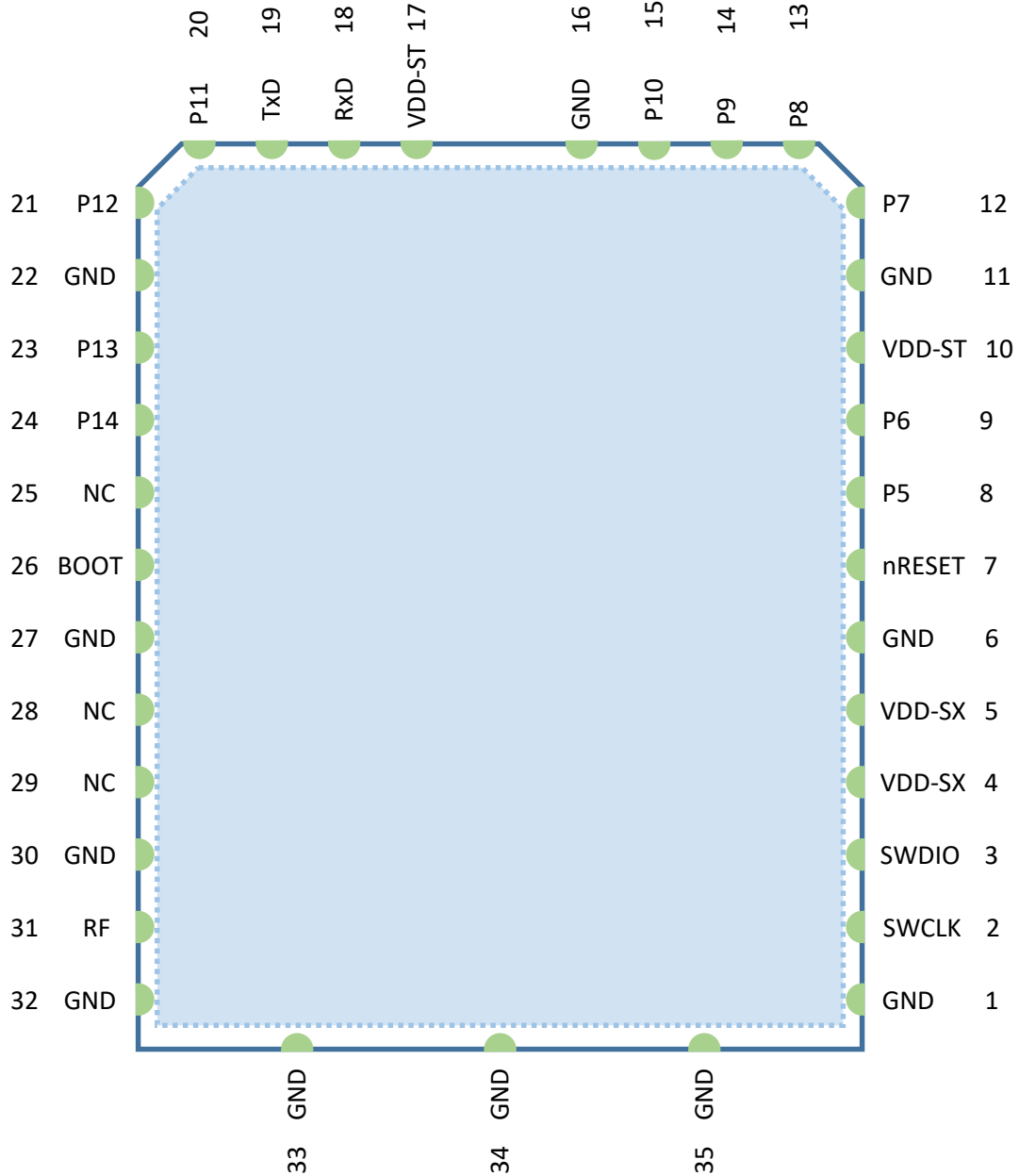

**Note:** Do not place any via or exposed pad in the inner area of the footprint to avoid short circuit between the via on customer board and the via on the bottom side of the ETH-LORA-M-AX-01

## LoRa Module specifications

Ethertronics produces a wide variety of standard and custom antennas to meet user needs

## Pins description

Pin Number	Pin Name	Pin Type	Description
1	GND	Supply	Ground Connection
2	SWCLK	Digital In/Out	Digital IO / JTCK / SWCLK
3	SWDIO	Digital In/Out	Digital IO / JTMS / SWDIO
4	VDD-SX	Supply	Supply Voltage for SX1272 part
5	VDD-SX	Supply	Supply Voltage for SX1272 part
6	GND	Supply	Ground Connection
7	nRESET	D In	nReset, internally pulled-up, internally filtered with capacitor
8	P5	Digital In/Out	Digital IO / USART1 CTS / MIPI DATA
9	P6	Digital In/Out	Digital IO / USART1 RTS / MIPI CLK
10	VDD-ST	Supply	Supply Voltage for ST part
11	GND	Supply	Ground Connection
12	P7	Digital In/Out	Digital IO / SPI2 MISO
13	P8	Digital In/Out	Digital IO / SPI2 MOSI / MIPI DATA
14	P9	Digital In/Out	Digital IO / SPI2 CLK / MIPI CLK
15	P10	Digital In/Out	Digital IO / SPI2 NSS / MIPI VIO
16	GND	Supply	Ground Connection
17	VDD-ST	Supply	Supply Voltage for ST part
18	RxD	Digital In/Out	Digital IO / USART1 RX
19	TxD	Digital In/Out	Digital IO / USART1 TX / MIPI VIO
20	P11	Digital In/Out	Digital IO/ Stop Mode Wake Up
21	P12	Digital In/Out	Digital IO / I2C1-SCL / Interface Selection
22	GND	Supply	Ground Connection
23	P13	Digital In/Out	Digital IO / I2C1-SDA / Interface Selection
24	P14	Digital In/Out	Digital IO / AS VDD
25	NC	NC	
26	BOOT	D In	Bootloader Pin 0, internally pulled down
27	GND	Supply	Ground Connection
28	NC	NC	
29	NC	NC	
30	GND	Supply	Ground Connection
31	RF	RF In/Out	LoRa Antenna Port
32,33,34,35	GND	Supply	Ground Connection

Please refer to document about the integration guideline for more details on pins description [\[2\]](#).

\*All dimensions provided in this document are for informational purposes only

LoRa Module specifications

Ethertronics produces a wide variety of standard and custom antennas to meet user needs

Recommended Landing Pattern (unit: mm, Top View)

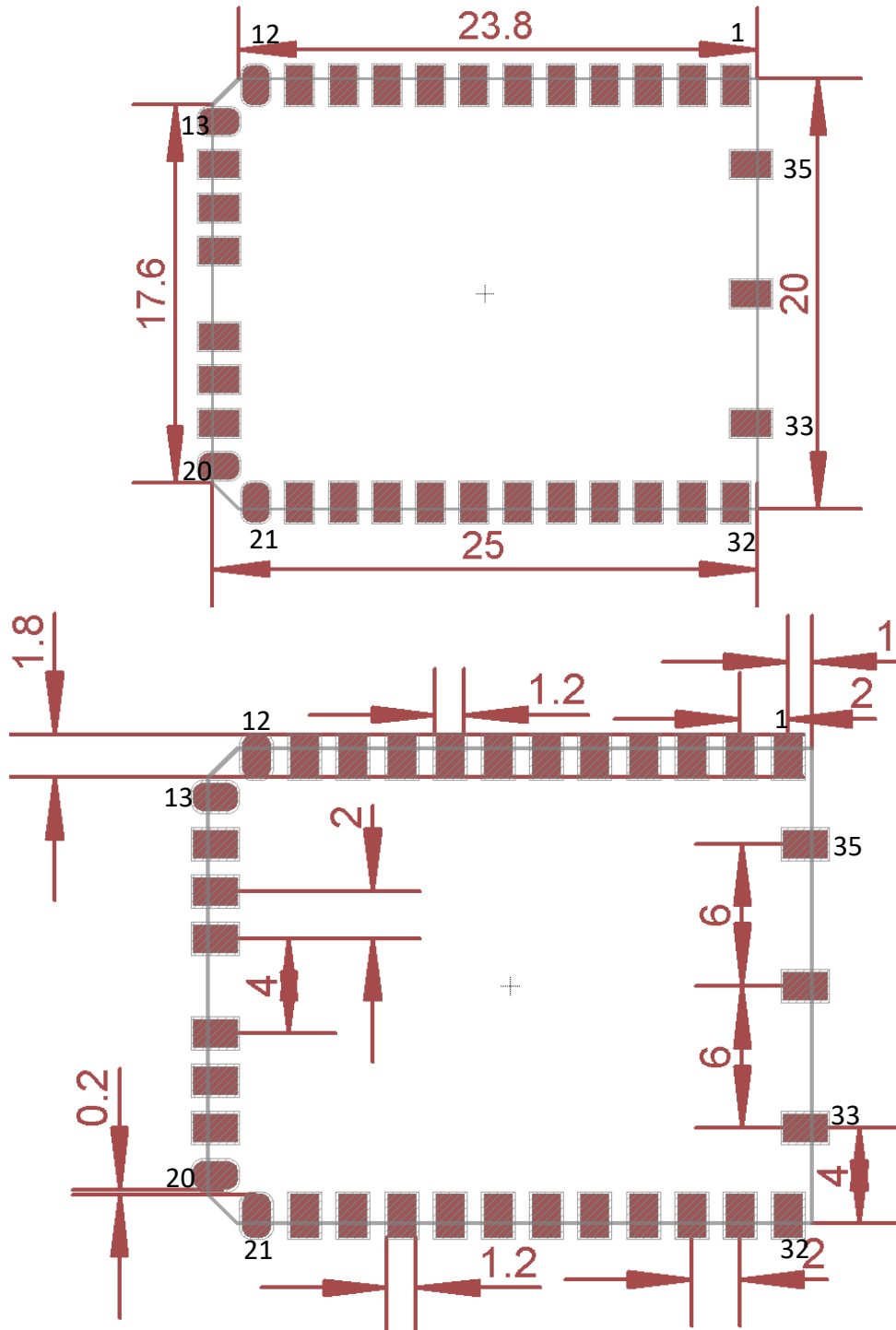

**Note:** Do not place any via or exposed pad in the inner area of the footprint to avoid short circuit between the via on customer board and the via on the bottom side of the EtherLoRa

\*All dimensions provided in this document are for informational purposes only

LoRa Module specifications

Ethertronics produces a wide variety of standard and custom antennas to meet user needs

Package dimension (in mm)

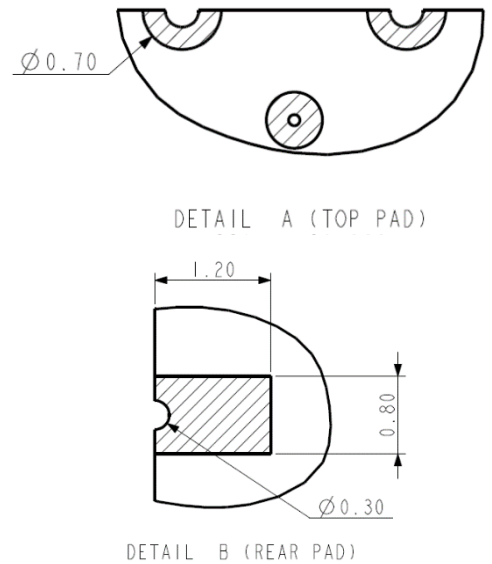
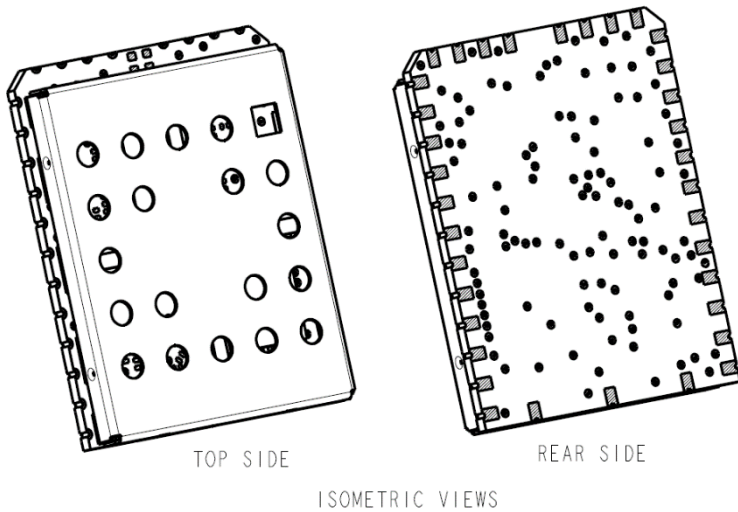
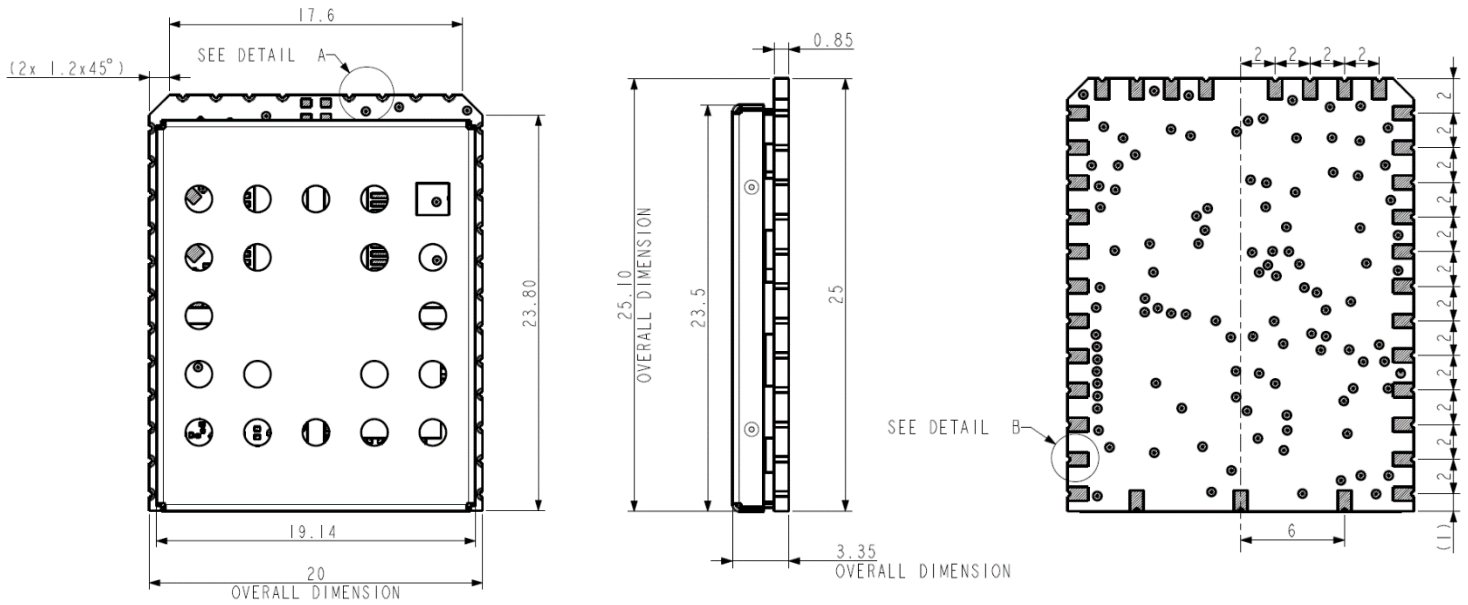

**Note:** Do not place any via or exposed pad in the inner area of the footprint to avoid short circuit between the via on customer board and the via on the bottom side of the EtherLoRa

\*All dimensions provided in this document are for informational purposes only



LoRa Module specifications

Ethertronics produces a wide variety of standard and custom antennas to meet user needs

Programming Interface

ETH-LORA-M-AX-01 is already pre-programmed with latest firmware available on the production date. Nonetheless, this module supports an In Application Programming (IAP) to perform a Firmware Upgrade. If in the future, the firmware is updated, user can download the firmware on the website and update the module using UART interface.

Please refer to application note about upgrading the module Firmware for more details [6].

Integration guide (UART Interface Application)

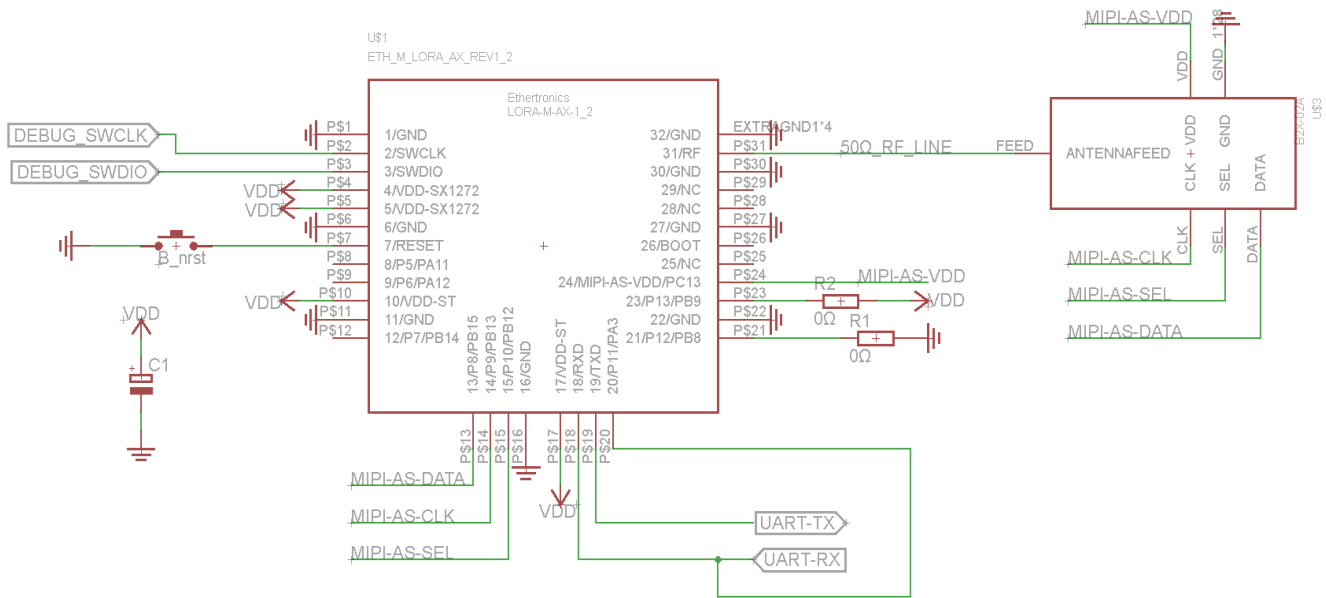

Schematic Part Name	Manufacturer	Manufacturer Part Number	Description
U\$1	Ethertronics, Inc.	LORA-M-AX-01	Lora Module V1.2
U\$3	Ethertronics, Inc.	B2	Active Steering Antenna (MIPI Interface)
B_nrst	Rafi	1.14002.1010000	SWITCH PUSH SPST-NO 0.1A 35V
R1	Panasonic	ERJ-S020R00X	Thick Film Resistors - SMD 0402 Zero ohm Jumper 0.05ohm AEC-Q200
R2	Panasonic	ERJ-S020R00X	Thick Film Resistors - SMD 0402 Zero ohm Jumper 0.05ohm AEC-Q200

This is a typical UART interface application schematic for ETH-LORA-M-AX-01. UART-RX signal is also connected to P11 in order to wake up the module when using the stop mode in low power mode. Please refer to document about the integration guideline for more details [2].

\*All dimensions provided in this document are for informational purposes only

## LoRa Module specifications

Ethertronics produces a wide variety of standard and custom antennas to meet user needs

## Ordering Information

Ordering Part Number	Description
ETH-LORA-M-AX-01-EU	Ethertronics SMD LoRa Module for 868 MHz
ETH-LORA-M-AX-01-US	Ethertronics SMD LoRa Module for 915 MHz

## Note

This device complies with part 15 of the FCC Rules. Operation is subject to the following two conditions:

- (1) This device may not cause harmful interference, and
- (2) This device must accept any interference received, including interference that may cause undesired operation.

**NOTE:** The grantee is not responsible for any changes or modifications not expressly approved by the party responsible for compliance. Such modifications could void the user's authority to operate the equipment.

Архангельск (8182)63-90-72  
 Астана (7172)727-132  
 Астрахань (8512)99-46-04  
 Барнаул (3852)73-04-60  
 Белгород (4722)40-23-64  
 Брянск (4832)59-03-52  
 Владивосток (423)249-28-31  
 Волгоград (844)278-03-48  
 Вологда (8172)26-41-59  
 Воронеж (473)204-51-73  
 Екатеринбург (343)384-55-89  
 Иваново (4932)77-34-06

Ижевск (3412)26-03-58  
 Иркутск (395)279-98-46  
 Казань (843)206-01-48  
 Калининград (4012)72-03-81  
 Калуга (4842)92-23-67  
 Кемерово (3842)65-04-62  
 Киров (8332)68-02-04  
 Краснодар (861)203-40-90  
 Красноярск (391)204-63-61  
 Курск (4712)77-13-04  
 Липецк (4742)52-20-81  
 Киргизия (996)312-96-26-47

Магнитогорск (3519)55-03-13  
 Москва (495)268-04-70  
 Мурманск (8152)59-64-93  
 Набережные Челны (8552)20-53-41  
 Нижний Новгород (831)429-08-12  
 Новокузнецк (3843)20-46-81  
 Новосибирск (383)227-86-73  
 Омск (3812)21-46-40  
 Орел (4862)44-53-42  
 Оренбург (3532)37-68-04  
 Пенза (8412)22-31-16  
 Россия (495)268-04-70

Пермь (342)205-81-47  
 Ростов-на-Дону (863)308-18-15  
 Рязань (4912)46-61-64  
 Самара (846)206-03-16  
 Санкт-Петербург (812)309-46-40  
 Саратов (845)249-38-78  
 Севастополь (8692)22-31-93  
 Симферополь (3652)67-13-56  
 Смоленск (4812)29-41-54  
 Сочи (862)225-72-31  
 Ставрополь (8652)20-65-13  
 Казахстан (772)734-952-31

Сургут (3462)77-98-35  
 Тверь (4822)63-31-35  
 Томск (3822)98-41-53  
 Тула (4872)74-02-29  
 Тюмень (3452)66-21-18  
 Ульяновск (8422)24-23-59  
 Уфа (347)229-48-12  
 Хабаровск (4212)92-98-04  
 Челябинск (351)202-03-61  
 Череповец (8202)49-02-64  
 Ярославль (4852)69-52-93

<https://avx.nt-rt.ru/> || [avx@nt-rt](mailto:avx@nt-rt)